

harman/kardon

AVR340

7 X 55W 7.1 CHANNEL A/V RECEIVER

SERVICE MANUAL



CONTENTS

ESD WARNING.....	2	TECH TIP HK2003-01.....	28
LEAKAGE TESTING.....	3	DISASSEMBLY.....	29
BASIC SPECIFICATIONS.....	4	UNIT EXPLODED VIEW.....	32
PACKAGING.....	5	EXPLODED VIEW PARTS LIST.....	33
FRONT PANEL CONTROLS.....	6	AMP BIAS ADJUSTMENT.....	34
REAR PANEL CONNECTIONS.....	9	BLOCK DIAGRAM.....	35
REMOTE CONTROL FUNCTIONS.....	12	ELECTRICAL PARTS LIST.....	36
CONNECTIONS.....	16	PCB DRAWINGS.....	80
OPERATION.....	19	SEMICONDUCTOR PINOUTS.....	86
TROUBLESHOOTING GUIDE.....	26	SCHEMATICS.....	178
PROCESSOR RESET.....	26	WIRING DIAGRAM.....	186
BULLETIN HK2006-01.....	27		

harman/kardon, Inc.
250 Crossways Park Dr.
Woodbury, New York 11797

Rev 0 3/2006

ELECTROSTATICALLY SENSITIVE (ES) DEVICES

Some semiconductor (solid state) devices can be damaged easily by static electricity. Such components commonly are called Electrostatically Sensitive (ES) Devices. Examples of typical ES devices are integrated circuits and some field effect transistors and semiconductor "chip" components.

The following techniques should be used to help reduce the incidence of component damage caused by static electricity.



1. Immediately before handling any semiconductor component or semiconductor-equipped assembly, drain off any electrostatic charge on your body by touching a known earth ground. Alternatively, obtain and wear a commercially available discharging wrist strap device, which should be removed for potential shock reasons prior to applying power to the unit under test.
2. After removing an electrical assembly equipped with ES devices, place the assembly on a conductive surface such as aluminum foil, to prevent electrostatic charge build-up or exposure of the assembly.
3. Use only a grounded-tip soldering iron to solder or unsolder ES devices.
4. Use only an anti-static solder removal device. Some solder removal devices not classified as "anti-static" can generate electrical charges sufficient to damage ES devices.
5. Do not use freon-propelled chemicals. These can generate electrical change sufficient to damage ES devices.
6. Do not remove a replacement ES device from its protective package until immediately before you are ready to install it. (Most replacement ES devices are packaged with leads electrically shorted together by conductive foam, aluminum foil or comparable conductive material.)
7. Immediately before removing the protective material from the leads of a replacement ES device, touch the protective material to the chassis or circuit assembly into which the device will be installed.

CAUTION : Be sure no power is applied to the chassis or circuit, and observe all other safety precautions.

8. Minimize bodily motions when handling unpackaged replacement ES devices. (Otherwise harmless motion such as the brushing together of your clothes fabric or the lifting of your foot from a carpeted floor can generate static electricity sufficient to damage an ES devices.

PRODUCT SAFETY NOTICE

Each precaution in this manual should be followed during servicing.

Components identified with the IEC symbol  in the parts list are special significance to safety. When replacing a component identified with , use only the replacement parts designated, or parts with the same ratings or resistance, wattage, or voltage that are designated in the parts list in this manual. Leakage-current or resistance measurements must be made to determine that exposed parts are acceptably insulated from the supply circuit before returning the product to the customer.

SAFETY PRECAUTIONS

The following check should be performed for the continued protection of the customer and service technician.

LEAKAGE CURRENT CHECK

Measure leakage current to a known earth ground (water pipe, conduit, etc.) by connecting a leakage current tester between the earth ground and all exposed metal parts of the appliance (input/output terminals, screwheads, metal overlays, control shaft, etc.). Plug the AC line cord of the appliance directly into a 120V AC 60Hz outlet and turn the AC power switch on. Any current measured must not exceed 0.5mA.

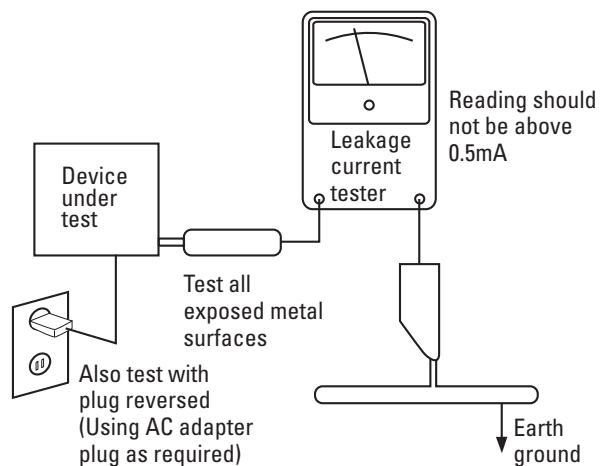

AC Leakage Test

ANY MEASUREMENTS NOT WITHIN THE LIMITS OUTLINED ABOVE ARE INDICATIVE OF A POTENTIAL SHOCK HAZARD AND MUST BE CORRECTED BEFORE RETURNING THE APPLIANCE TO THE CUSTOMER.

AVR 340 TECHNICAL SPECIFICATIONS

Audio Section

Stereo Mode

Continuous Average Power (FTC)

70 Watts per channel, 20Hz–20kHz,
@ <0.07% THD, both channels driven into 8 ohms

Seven-Channel Surround Modes

Power per Individual Channel

Front L&R channels:
55 Watts per channel
@ <0.07% THD, 20Hz–20kHz into 8 ohms

Center channel:
55 Watts @ <0.07% THD, 20Hz–20kHz into 8 ohms

Surround (L & R Side, L & R Back) channels:
55 Watts per channel
@ <0.07% THD, 20Hz–20kHz into 8 ohms

Input Sensitivity/Impedance

Linear (High-Level) 200mV/47k ohms

Signal-to-Noise Ratio (IHF-A) 100dB

Surround System Adjacent Channel Separation

Pro Logic 40dB

Dolby Digital 55dB

DTS 55dB

Frequency Response

@ 1W (+0dB, –3dB) 10Hz – 130kHz

High Instantaneous

Current Capability (HCC) ±35 Amps

Transient Intermodulation

Distortion (TIM) Unmeasurable

Slew Rate 40V/μsec

FM Tuner Section

Frequency Range 87.5–108.0MHz

Usable Sensitivity IHF 1.3μV/13.2dBf

Signal-to-Noise Ratio Mono/Stereo 70/68dB

Distortion Mono/Stereo 0.2/0.3%

Stereo Separation 40dB @ 1kHz

Selectivity ±400kHz, 70dB

Image Rejection 80dB

IF Rejection 90dB

AM Tuner Section

Frequency Range 520–1720kHz

Signal-to-Noise Ratio 45dB

Usable Sensitivity Loop 500μV

Distortion 1kHz, 50% Mod 0.8%

Selectivity ±10kHz, 30dB

Video Section

Television Format NTSC

Input Level/Impedance 1Vp-p/75 ohms

Output Level/Impedance 1Vp-p/75 ohms

Video Frequency Response
(Composite and S-Video) 10Hz–8MHz (–3dB)

Video Frequency Response
(Component Video) 10Hz–50MHz (–3dB)

General

Power Requirement AC 120V/60Hz

Power Consumption 118W idle, 890W maximum
(7 channels driven)

Dimensions

(Product)

(Shipping)

Width 17.3 inches (440mm)

21.5 inches (545mm)

Height 6.6 inches (168mm)

9.9 inches (251mm)

Depth 15 inches (382mm)

17.9 inches (455mm)

Weight (Product)

30.6 lb (13.9kg)

(Shipping)

35.2 lb (16kg)

Depth measurement includes knobs, buttons and terminal connections.

Height measurement includes feet and chassis.

All features and specifications are subject to change without notice.

Harman Kardon, Harman International, Power for the Digital Revolution and Logic 7 are registered trademarks, and The Bridge and EzSet/EQ are trademarks, of Harman International Industries, Incorporated.

Dolby, Pro Logic and the double-D symbol are registered trademarks of Dolby Laboratories. Manufactured under license from Dolby Laboratories.

DTS, DTS Surround, DTS-ES, DTS 96/24 and DTS Neo:6 are registered trademarks of DTS, Inc.

VMAx is a registered trademark of Harman International Industries, Incorporated, and is an implementation of Cooper Bauck Transaural Stereo under patent license.

SACD is a trademark of Sony Electronics Inc.

iPod is a registered trademark, and Shuffle is a trademark, of Apple Computer, Inc.

Please register your product on our Web site at www.harmankardon.com. Note: You'll need the product's serial number.

At the same time, you may choose to be notified about our new products and/or special promotions.

1. Instruction manual ass'y - Accessories

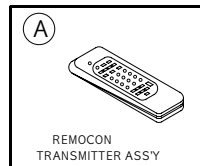
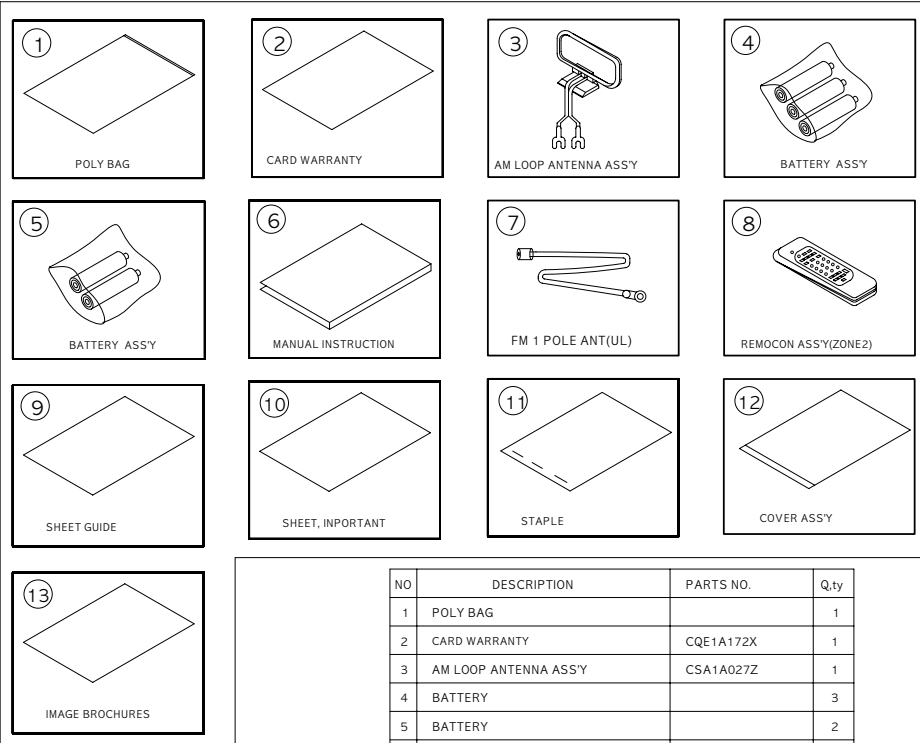

NO	DESCRIPTION	PARTS NO.	Q.ty
1	POLY BAG		1
2	CARD WARRANTY	CQE1A172X	1
3	AM LOOP ANTENNA ASS'Y	CSA1A027Z	1
4	BATTERY		3
5	BATTERY		2
6	INSTRUCTION MANUAL	CQX1A1027Z	1
7	FM 1 POL ANT(UL)	CSA1A019Z	1
8	REMOCON ASS'Y(ZONE2)	RH18Z00	1
9	SHEET GUIDE	CQE1A260Z	1
10	SHEET INPORTANT		1
11	STAPLE		3
12	COVER ASS'Y	CGRAVR130ZA	1
	1 COVER A	CGR1A331M7H43	1
	2 COVER B	CGR1A332M7H43	1
	3 SHEET,FRONT COVER	CQE1A219Z	1
	4 PAD, COVER	CPS1A676	1
	5 BAG, POLY		1
13	IMAGE BROCHURES		1
A	REMOCON ASS'Y	RB30L00	1

2. Package Drawing

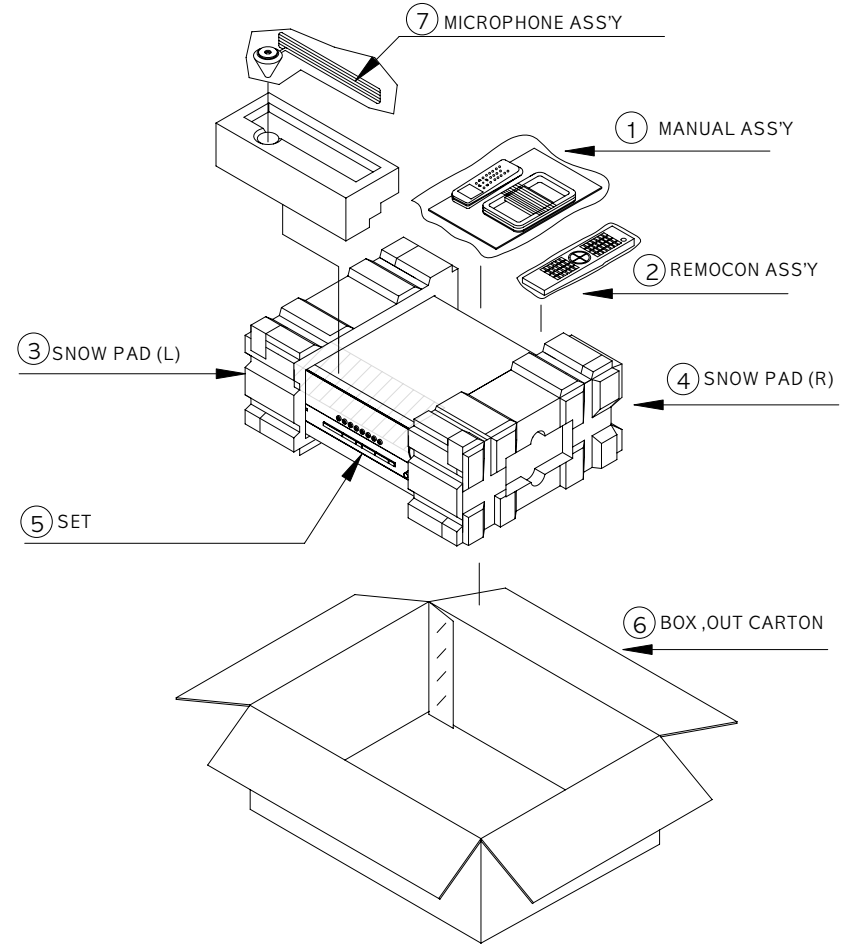

NO	DESCRIPTION	PARTS NO.	Q.ty
1	MANUAL ASS'Y		1
2	REMOCON ASS'Y	RB30L00	1
3	SNOW,PAD(L)	CPS5A564	1
4	SNOW,PAD(R)	CPS5A565	1
5	SET	AVR 340	1
6	BOX,OUT CARTON	CPG1A797X	1
7	MICROPHONE ASS'Y	CJXAVR340MICRO	1

FRONT-PANEL CONTROLS

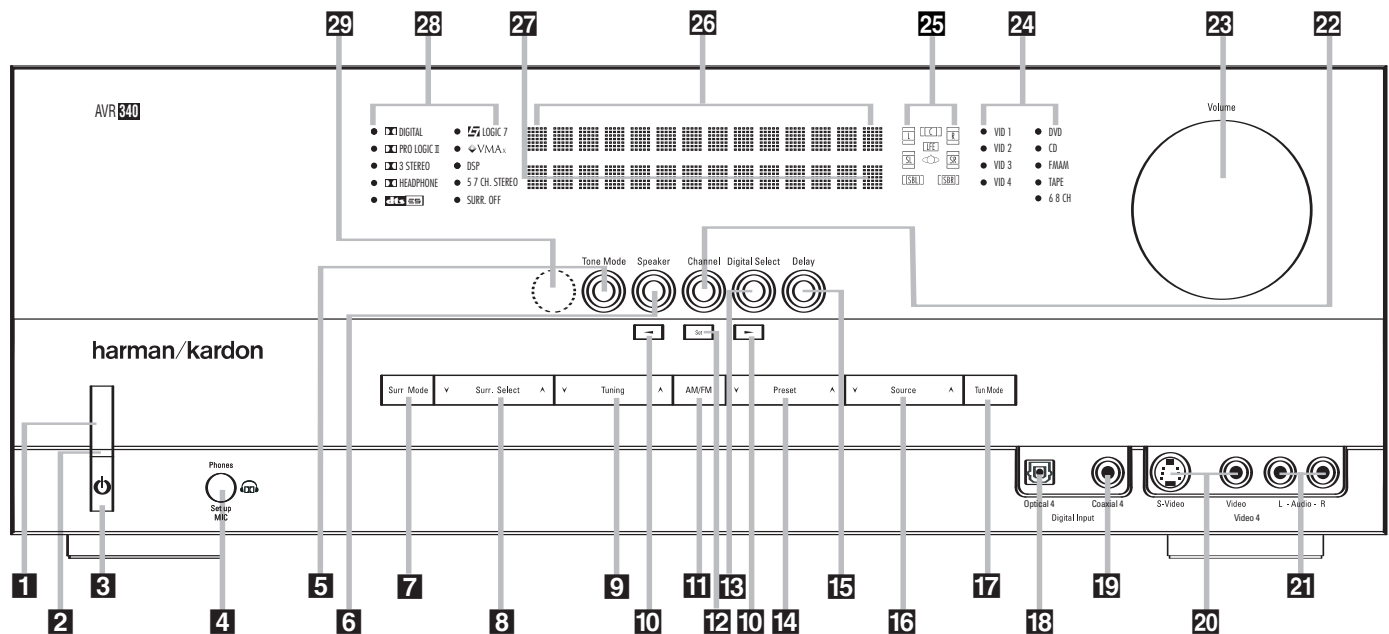

NOTE: To make it easier to follow the instructions that refer to this illustration, a larger copy may be downloaded from the Product Support section for this product at www.harmankardon.com.

- | | | |
|---|---|---|
| <p>1 Main Power Switch
 2 Power Indicator
 3 Standby/On Switch
 4 Headphone Jack
 5 Tone Mode
 6 Speaker Selector
 7 Surround Mode Group Selector
 8 Surround Mode Selector
 9 Tuning Selector
 10 ◀▶ Buttons</p> | <p>11 Tuner Band Selector
 12 Set Button
 13 Digital Input Selector
 14 Preset Station Selector
 15 Delay Adjust Selector
 16 Input Source Selector
 17 Tuner Mode Selector
 18 Optical 4 Digital Audio Input
 19 Coaxial 4 Digital Audio Input
 20 Video 4 Video Input Jacks</p> | <p>21 Video 4 Audio Input Jacks
 22 Channel Adjust Selector
 23 Volume Control
 24 Input Indicators
 25 Speaker/Channel Input Indicators
 26 Upper Display Line
 27 Lower Display Line
 28 Surround Mode Indicators
 29 Remote Sensor Window</p> |
|---|---|---|

1 Main Power Switch: Press this button to apply power to the AVR 340. When the switch is pressed in, the unit is in a Standby mode, as indicated by the amber **Power Indicator 2**. This button **MUST** be pressed in to operate the unit. To turn the unit off and prevent the use of the remote control, this switch should be pressed until it pops out from the front panel and the word "OFF" is seen at the top of the switch.

NOTE: This switch is normally left in the "ON" position.

2 Power Indicator: This LED lights amber when the unit is in the Standby mode to signal that the AVR is ready to be turned on. When the unit is in operation, the indicator is blue.

3 Standby/On Switch: When the **Main Power Switch 1** is "ON," press this button to turn on the AVR 340; press it again to turn the unit off. The **Power Indicator 2** turns blue when the unit is on.

4 Headphone Jack: This jack may be used to listen to the AVR 340's output through a pair of headphones. The speakers will automatically be turned off when the headphone jack is in use. When configuring your system using EzSet/EQ, the calibration microphone should be plugged into this jack using the supplied adaptor that converts the small mini-plug at the end of the microphone's cord to a 1/4" plug.

5 Tone Mode: This button controls the tone mode settings, enabling adjustment of the bass and treble boost/cut. You may also use it to take the tone controls out of the signal path completely for "flat" response. The first press of the button displays a **TONE IN** message in the **Lower Display Line 27** and in the on-screen display. To take the controls out of the signal path, press either of the **Buttons 10** until the display reads **TONE OUT**.

To change the bass or treble settings, make sure that **TONE IN** appears in the **Lower Display Line 27** or press either of the **Buttons 10** until it does.

Press the **Tone Mode Button 5** until the desired option of **TREBLE MODE** or **BASS MODE** appears in the **Lower Display Line 27** and in the on-screen display and then press either of the **Buttons 10** to enter the desired boost or cut setting. Both treble and bass contours may be boosted or cut by up to + or -10dB in increments of 2dB. See pages 23 and 34 for more information on the tone controls.

NOTE: The AVR 340 is not equipped with a traditional Balance control. When listening to two-channel materials, if you wish to adjust the stereo image, you may use the **Channel Adjust Selector 22** to increase or decrease the level of the left front channel by up to + or -10dB, and then to decrease or increase the right front channel by the corresponding amount. However, when listening to surround materials and most two-channel materials, it is recommended that you leave these settings at the results obtained during the configuration process described on pages 19 through 33.

FRONT-PANEL CONTROLS

6 Speaker Selector: Press this button to begin the process of configuring the unit to match the type of speakers used in your listening room. (See pages 28–30 for more information on speaker setup and configuration.)

7 Surround Mode Group Selector: Press this button to select the top-level group of surround modes. Each press of the button will select the current or last used mode in each of the surround mode groups (e.g., Dolby, DTS, DTS Neo:6, Logic 7, DSP, Stereo). When the button is pressed so that the name of the surround mode group appears in the on-screen display and in the **Lower Display Line 27**, press the **Surround Mode Selector 8** to cycle through the individual modes available. For example, press this button to select Dolby modes, and then press the **Surround Mode Selector 8** to choose from the various Dolby mode options.

8 Surround Mode Selector: Press this button to select from among the available surround mode options for the mode group selected. The specific modes will vary based on the number of speakers available, the mode group and if the input source is digital or analog. For example, press the **Surround Mode Group Selector 7** to select a main mode grouping such as Dolby or Logic 7, and then press this button to see the specific mode choices available. Note that the digital surround modes, such as Dolby Digital and DTS, may not be accessed unless that type of source signal is present, such as when a DVD movie or television signal programmed in Dolby Digital or DTS surround sound is playing. For more information on surround mode selection, see pages 25 and 35–41.

9 Tuning Selector: Press the left side of the button to tune lower-frequency stations and the right side of the button to tune higher-frequency stations. When the tuner is in the Manual mode, each tap will increase or decrease the frequency by one increment. When the tuner receives a strong enough signal for adequate reception, **MANUAL TUNED** will appear in the on-screen display and the **Lower Display Line 27**. When the tuner is the Auto mode, press the button once, and the tuner will scan for a station with acceptable signal strength. When the next station with a strong signal is tuned the scan will stop and the on-screen display and **Lower Display Line 27** will indicate **AUTO TUNED**. When an FM Stereo station is tuned, the display will read **AUTO ST TUNED**.

To switch back and forth between the Auto and Manual tuning modes, press the **Tuner Mode Selector 17**.

10 ◀▶ Buttons: When configuring the AVR 340's settings, use these buttons to select from the available choices.

11 Tuner Band Selector: Press this button to turn the AVR on and to select the Tuner as the input. Press it again to switch between the AM and FM frequency bands. (See page 41 for more information on the tuner.)

12 Set Button: When making choices during the setup and configuration process, press this button to enter the desired setting into the AVR 340's memory.

13 Digital Input Selector: Press this button to select one of the digital audio inputs or the analog audio input for any source. (See pages 38–41 for more information on digital audio.)

14 Preset Stations Selector: Press this button to scroll up or down through the list of stations that have been entered into the preset memory. (See page 41 for more information on tuner presets.)

15 Delay Adjust Selector: Press this button to begin the steps required to enter delay settings. (See pages 30–31 for more information on delay times.)

16 Input Source Selector: Press this button to change the input by scrolling up or down through the list of **Input Indicators 24**.

17 Tuner Mode Selector: Press this button to select Auto or Manual tuning. When the button is pressed so that the **AUTO** appears in the **Lower Display Line 27**, the tuner will search for the next station with an acceptable signal when the **Tuning Selector 9 21** is pressed. When the button is pressed so that **MANUAL** appears in the **Lower Display Line 27**, each press of the **Tuning Selector 9 21** will increase the frequency. This button may also be used to switch between Stereo and Mono modes for FM radio reception. When weak reception is encountered, press the button so that **MANUAL** appears in the **Lower Display Line 27** and on the on-screen display to switch to Mono reception. Press it again to switch back to Stereo mode. (See page 41 for more information on using the tuner.)

18 Optical 4 Digital Audio Input: Connect the optical digital audio output of an audio or video product to this jack. When the input is not in use, the built-in shutter will close to avoid dust contamination that might degrade future performance.

19 Coaxial 4 Digital Audio Input: This jack is used for connection to the output of portable audio devices, video game consoles or other products that have a coax digital audio jack.

20 Video 4 Video Input Jacks: These jacks may be used for temporary connection to the composite or S-video output of video games, camcorders or other portable video products. You may make a connection to either jack at any time, but not to both simultaneously.

21 Video 4 Audio Input Jacks: These audio jacks may be used for temporary connection to video games or portable audio/video products such as camcorders and portable audio players.

NOTE: The AVR 340 is shipped with two covers that may be installed over the front-panel input jacks when they are not in use.

22 Channel Adjust Selector: Press this button to begin the process of trimming the channel output levels using an external audio source. (For more information on output level trim adjustment, see page 31.)

23 Volume Control: Turn this knob clockwise to increase the volume, counterclockwise to decrease the volume. If the AVR 340 is muted, adjusting the **Volume Control 23 38** will automatically release the unit from the silenced condition.

24 Input Indicators: The current selected source will appear as one of these indicators. When the unit is turned on, the entire list of available modes will light briefly, and then revert to normal operation with only the active mode indicator illuminated.

NOTE: When **Bridge/DMP** has been selected as the input source, no **Input Indicator 24** will light. **DMP/THE BRIDGE IS CONNECTED** will scroll across the **Upper Display Line 26**, unless you have retitled the source name, in which case that name will appear. See page 22 for more information on input titling.

25 Speaker/Channel Input Indicators: These indicators are multipurpose, indicating both the speaker type selected for each channel and the incoming data-signal configuration. The left, center, right, right surround and left surround speaker indicators are composed of three boxes, while the subwoofer is a single box. The center box lights when a "small" speaker is selected, and the two outer boxes light when "large" speakers are selected. When none of the boxes are lit for the center, surround or subwoofer channels, no speaker has been assigned that position. (See pages 28–29 for more information on configuring speakers.)

NOTE: When you have reassigned the surround back speakers to the remote zone using the **MULTI ROOM SETUP** menu, the boxes that indicate the presence of the surround back speakers will automatically disappear, reflecting the fact that the main listening area is now configured for 5.1-channel operation.

FRONT - PANEL CONTROLS

(See page 46 for more information on reassigning the surround back speakers for multiroom use.)

The letters inside each box display the active input channels. For standard analog sources, only the L and R will light, indicating a stereo input. For a digital source, the indicators will light to display the channels being received at the digital input. When the letters flash, the digital input has been interrupted. (See page 39 for more information on the Channel Indicators.)

26 Upper Display Line: Depending on the unit's status, a variety of messages will appear here. In normal operation, this line will show current input source and which analog or digital input is in use. When the tuner is the input, this line will identify the station as AM or FM and show the frequency and preset number, if any.

27 Lower Display Line: Depending on the unit's status, a variety of messages will appear here. In normal operation, the current surround mode will show here.

28 Surround Mode Indicators: The current selected surround mode will appear as one of these indicators. Note that when the unit is turned on, the entire list of available modes will light briefly, and then revert to normal operation with only the active mode indicator illuminated.

NOTE: When the Dolby Virtual Speaker mode is in use, no **Surround Mode Indicator 28** will light. However, the surround mode name will scroll in the **Lower Display Line 27**.

29 Remote Sensor Window: The sensor behind this window receives infrared signals from the remote control. Aim the remote at this area and do not block or cover it.

REAR-PANEL CONNECTIONS

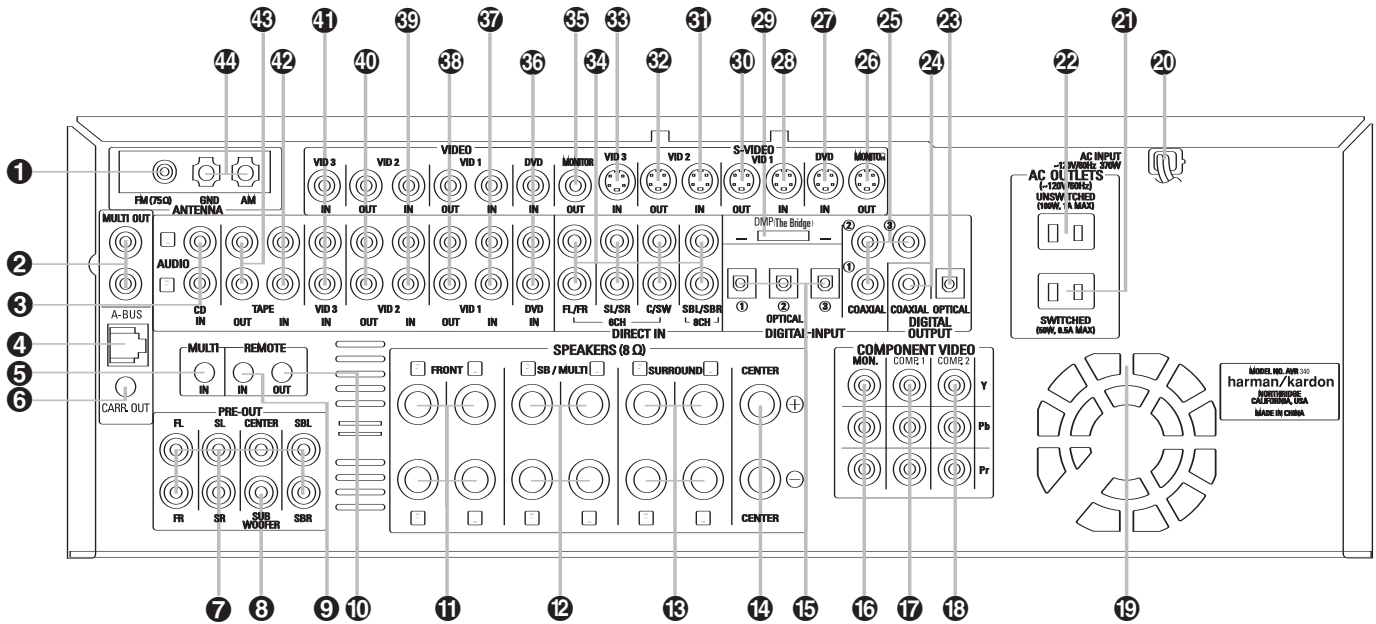

NOTE: To make it easier to follow the instructions that refer to this illustration, a larger copy may be downloaded from the Product Support section for this product at www.harmankardon.com.

- 1 FM Antenna Jack
- 2 Multiroom Audio Outputs
- 3 CD Audio Inputs
- 4 A-BUS® Connector
- 5 Multiroom IR Input
- 6 Remote IR Carrier Output
- 7 Preamp Outputs
- 8 Subwoofer Output
- 9 Remote IR Input
- 10 Remote IR Output
- 11 Front Speaker Outputs
- 12 Surround Back/Multiroom Speaker Outputs
- 13 Surround Speaker Outputs
- 14 Center Speaker Outputs
- 15 Optical Digital Audio Inputs
- 16 Component Video Monitor Outputs
- 17 Component Video 1 Inputs
- 18 Component Video 2 Inputs
- 19 Fan Vents
- 20 AC Power Cord
- 21 Switched AC Accessory Outlet
- 22 Unswitched AC Accessory Outlet
- 23 Optical Digital Audio Output
- 24 Coaxial Digital Audio Output
- 25 Coaxial Digital Audio Inputs
- 26 S-Video Monitor Output
- 27 DVD S-Video Input
- 28 Video 1 S-Video Input
- 29 Bridge™ DMP Connector
- 30 Video 1 S-Video Output
- 31 Video 2 S-Video Input
- 32 Video 2 S-Video Output
- 33 Video 3 S-Video Input
- 34 6/8-Channel Direct Inputs
- 35 Video Monitor Output
- 36 DVD Audio/Video Inputs
- 37 Video 1 Audio/Video Inputs
- 38 Video 1 Audio/Video Outputs
- 39 Video 2 Audio/Video Inputs
- 40 Video 2 Audio/Video Outputs
- 41 Video 3 Audio/Video Inputs
- 42 Tape Inputs
- 43 Tape Outputs
- 44 AM Antenna Terminals

NOTE: To assist in making the correct connections for multichannel input, output and speaker connections, all connection jacks and terminals are color-coded in conformance with the CEA standards as follows:

Front Left: White
Front Right: Red

Center: Green
Surround Left: Blue
Surround Right: Gray
Surround Back Left: Brown
Surround Back Right: Tan
Subwoofer: Purple
Coaxial Digital Audio: Orange

Composite Video: Yellow
Component Video "Y": Green
Component Video "Pr": Red
Component Video "Pb": Blue

1 FM Antenna Jack: Connect the supplied indoor (or an optional external) FM antenna to this terminal.

2 Multiroom Audio Outputs: Connect these jacks to the optional external audio power amplifier that is used for multizone distribution.

3 CD Audio Inputs: Connect these jacks to the analog audio outputs of a compact disc player or CD changer.

4 A-BUS® Connector: Connect this jack to an optional A-BUS remote room product to extend the

multiroom capabilities of your AVR 340. See page 17 for more information on A-BUS.

5 Multiroom IR Input: Connect the output of an IR sensor in a remote room to this jack to control the AVR 340's multiroom system and source devices from

REAR-PANEL CONNECTIONS

the remote room. See page 46 for more information on multiroom operation.

6 Remote IR Carrier Output: The output of this jack is the full signal received at the **Remote Sensor Window 29**, or input through the **Remote IR Input 9**, including the carrier frequency that is stripped from these signals at the **Remote IR Output 10**. Use this output to extend IR remote signals to the inputs of compatible products that require the full IR signal by direct connection to the product's remote IR input, or through the use of optional, external IR "blasters." If you are in doubt as to which of the two IR Output jacks to use, we recommend that you consult with your dealer or installer, or check with the manufacturer of the external equipment you wish to control.

7 Preamp Outputs: Connect these jacks to an optional, external power amplifier for applications where higher power is desired.

8 Subwoofer Output: Connect this jack to the line-level input of a powered subwoofer. If an external subwoofer amplifier is used, connect this jack to the subwoofer amplifier input.

9 Remote IR Input: If the AVR 340's front-panel IR sensor is blocked due to cabinet doors or other obstructions, an external IR sensor may be used. Connect the output of the sensor to this jack.

10 Remote IR Output: This connection permits the IR sensor in the receiver to serve other remote controlled devices. Connect this jack to the "IR IN" jack on Harman Kardon (or other compatible) equipment.

11 Front Speaker Outputs: Connect these outputs to the matching + or – terminals on your left and right speakers. When making speaker connections always make certain to maintain correct polarity by connecting the color-coded (white for front left and red for front right) (+) terminals on the AVR 340 to the red (+) terminals on the speakers and the black (–) terminals on the AVR 340 to the black (–) terminals on the speakers. See page 16 for more information on speaker polarity.

1 Surround Back/Multiroom Speaker Outputs: These speaker terminals are normally used to power the surround back speakers in a 7.1-channel system. However, they may also be used to power the speakers in a second zone, which will receive the output selected for a multiroom system. To change the output fed to these terminals from the default of the Surround Back speakers to the Multiroom Output, you must change a setting in the **MULTI ROOM SETUP** menu of the OSD system. See page 46 for more information on configuring this speaker output. In normal surround system use, the brown and black terminals are the surround back left channel positive (+) and negative (–) connections and the tan

and black terminals are the surround back right positive (+) and negative (–) terminals. For multiroom use, connect the brown and black SBL terminals to the red and black connections on the left remote zone speaker and connect the tan and black SBR terminals to the red and black terminals on the right remote zone speaker.

13 Surround Speaker Outputs: Connect these outputs to the matching + and – terminals on your surround channel speakers. In conformance with the CEA color-code specification, the blue terminal is the positive, or "+," terminal that should be connected to the red (+) terminal on the Surround Left speaker with older color-coding, while the gray terminal should be connected to the red (+) terminal on the Surround Right speaker with the older color-coding. Connect the black (–) terminal on the AVR to the matching black negative (–) terminals for each surround speaker. (See page 16 for more information on speaker polarity.)

14 Center Speaker Outputs: Connect these outputs to the matching + and – terminals on your center channel speaker. In conformance with the CEA color-code specification, the green terminal is the positive, or "+," terminal that should be connected to the red (+) terminal on speakers with the older color-coding. Connect the black (–) terminal on the AVR to the black (–) terminal on your speaker. (See page 16 for more information on speaker polarity.)

15 Optical Digital Audio Inputs: Connect the optical digital output from a DVD player, HDTV receiver, LD player or CD player to these jacks. The signal may be a Dolby Digital signal, a DTS signal or a standard PCM digital source.

16 Component Video Monitor Outputs: Connect these outputs to the component video inputs of a video projector or monitor. When a source connected to one of the **Component Video Inputs 17-18** is selected, the signal will be sent to these jacks.

17 Component Video 1 Inputs: Connect the Y/Pr/Pb component video outputs of a DVD player, HDTV set-top converter, satellite receiver or other video source device with component video outputs to these jacks.

18 Component Video 2 Inputs: Connect the Y/Pr/Pb component video outputs of a DVD player, HDTV set-top converter, satellite receiver or other video source device with component video outputs to these jacks.

See page 22 for information on assigning the **Component Video 1 and 2 Inputs 17-18** to the appropriate source inputs.

19 Fan Vents: These ventilation holes are the output of the AVR 340's airflow system. To ensure proper

operation of the unit and to avoid possible damage to delicate surfaces behind the AVR, make certain that these holes are not blocked and that there is at least 3 inches of open space between the vent holes and any other surface. It is normal for the fan to remain off at most normal volume levels. An automatic temperature sensor turns the fan on only when it is needed.

20 AC Power Cord: Connect the AC power cord to a non-switched AC wall outlet.

21 Switched AC Accessory Outlet: These outlets may be used to power any device you wish to have turned on when the AVR 340 is turned on.

22 Unswitched AC Accessory Outlet: This outlet may be used to power any AC device. The power will remain on at this outlet regardless of whether the AVR 340 is on or off.

NOTE: The total power consumption of all devices connected to the accessory outlets should not exceed 100 watts.

23 Optical Digital Audio Output: Connect this jack to the optical digital input connector on a CD-R/RW, MiniDisc or other digital recorder.

24 Coaxial Digital Audio Output: Connect this jack to the coaxial digital input of a CD-R/RW, MiniDisc or other digital recorder.

25 Coaxial Digital Audio Inputs: Connect the coax digital output from a DVD player, HDTV receiver, LD player or CD player to these jacks. The signal may be a Dolby Digital signal, DTS signal or a standard PCM digital source. Do not connect the RF digital output of an LD player to these jacks.

26 S-Video Monitor Output: If any of the input sources used in your system have S-video connections to the AVR, connect this jack to the S-video input on your television, projector or other video display.

NOTE: Thanks to the AVR 340's cross-conversion capability, if your video display device is equipped with component (Y/Pb/Pr) video inputs, you need only to connect the **Component Video Monitor Outputs 16** to your display device, and the AVR 340 will automatically convert all composite and S-video source signals to the component video format for display. You will also be able to view the AVR 340's on-screen displays using just the component video connection, unless the source device is a high-definition (720p, 1080i or 1080p) video device, in which case you would then need to either switch to a 480p source or connect the **Video Monitor Output 26** or the **S-Video Monitor Output 26** to your video display in order to view the on-screen displays.

27 DVD S-Video Input: Connect the S-video output of a DVD player or other video source to this jack.

REAR-PANEL CONNECTIONS

28 Video 1 S-Video Input: If the product connected to the **Video 1 Audio Inputs 37** has S-video capability, connect this jack to the PLAY/OUT S-video jack on that unit and then make certain that the **S-Video Monitor Output 25** is connected as described above.

29 Bridge Digital Media Player (DMP) Connector: With the AVR 340 turned off, connect the optional Harman Kardon Bridge to this connector. When the Digital Media Player source is selected, you may view iPod control and navigation messages on your video display (if one is connected to one of the **Video Monitor Outputs 25/35**), and in the **Upper and Lower Display Lines 26/27**. You may navigate the iPod and select tracks for playback using the **▲/▼/◀/▶ Buttons 14 15**, the **Set Button 16** and **Transport Controls 27** on your AVR remote. See page 42 for more information.

30 Video 1 S-Video Output: If the product connected to the **Video 1 Audio/Video Outputs 35** has S-video capability, connect this jack to the REC/IN S-video jack on that unit.

31 Video 2 S-Video Input: If the product connected to the **Video 2 Audio/Video Inputs 39** has S-video capability, connect this jack to the PLAY/OUT S-video jack on that unit and then make certain that the **S-Video Monitor Output 25** is connected as described above.

32 Video 2 S-Video Output: If the product connected to the **Video 2 Audio Outputs 40** has S-video capability, connect this jack to the REC/IN S-video jack on that unit.

33 Video 3 S-Video Input: If the product connected to the **Video 3 Audio Inputs 41** has S-video capability, connect this jack to the PLAY/OUT S-video jack on that unit and then make certain that the **S-Video Monitor Output 25** is connected as described above.

34 6/8-Channel Direct Inputs: These jacks are used for connection to source devices such as DVD-Audio or SACD™ players with discrete analog outputs. Depending on the source device in use, all eight jacks may be used, though in many cases only connections to the front left/right, center, surround left/right and LFE (subwoofer input) jacks will be used for standard 5.1 audio signals.

35 Video Monitor Output: Connect this jack to the composite video input of a TV monitor or video projector to view the on-screen menus and the output of a standard video source.

NOTE: Thanks to the AVR 340's cross-conversion capability, if your video display device is equipped with component (Y/Pb/Pr) video inputs, you need only to connect the **Component Video Monitor Outputs 16** to your display device, and the AVR 340 will convert all composite and S-video source signals to component video. You will also be able to view the AVR 340's on-screen displays using the component video connection, unless the source device is high-definition (720p or 1080i) video, in which case you should either switch to a 480p source or connect the **Video** or the **S-Video Monitor Output 25/35** to your video display to view the on-screen displays.

36 DVD Audio/Video Inputs: Connect the composite video and L/R analog audio outputs of a DVD player or other video source to these jacks.

37 Video 1 Audio/Video Inputs: Connect the composite video and L/R analog audio PLAY/OUT jacks of a VCR or other video source to these jacks.

38 Video 1 Audio/Video Outputs: Connect the composite video and L/R analog audio REC/IN jacks of a VCR or other video recording device such as a DVD recorder or PVR to these jacks.

39 Video 2 Audio/Video Inputs: Connect the composite video and L/R analog audio PLAY/OUT jacks of a cable television box or other video source to these jacks.

40 Video 2 Audio/Video Outputs: Connect the composite video and L/R analog audio REC/IN jacks of a VCR or other video recording device such as a DVD recorder or PVR to these jacks.

41 Video 3 Audio/Video Inputs: Connect the composite video and L/R analog audio PLAY/OUT jacks of an HDTV tuner or other video source to these jacks.

42 Tape Inputs: Connect these jacks to the PLAY/OUT jacks of an audio recorder.

43 Tape Outputs: Connect these jacks to the RECORD/INPUT jacks of an audio recorder.

44 AM Antenna Terminals: Connect the AM loop antenna supplied with the receiver to these terminals. If an external AM antenna is used, make connections to the **AM** and **GND** terminals in accordance with the instructions supplied with the antenna.

NOTE ON VIDEO CONNECTIONS: When connecting a video source product such as a VCR, DVD player, satellite receiver, cable set-top box, personal video recorder or video game to the AVR 340, you may use either a composite or S-video connection, but not both, for each source device.

The AVR 340 features cross-conversion capability, enabling you to benefit from higher-quality viewing of your video sources, even those that use composite or S-video switching, when connected to your video display with component video inputs.

MAIN REMOTE CONTROL FUNCTIONS

- 1 Power Off Button
- 2 IR Transmitter Window
- 3 Program Indicator
- 4 Power On Button
- 5 Input Selectors
- 6 AVR Selector
- 7 AM/FM Tuner Select
- 8 Dim Button
- 9 Test Button
- 10 Sleep Button
- 11 DSP Surround Mode Selector
- 12 Night Mode
- 13 Channel Select Button
- 14 ▲/▼ Buttons
- 15 ◀/▶ Buttons
- 16 Set Button
- 17 Digital Select
- 18 Numeric Keys
- 19 Tuner Mode
- 20 Direct Button
- 21 Tuning Up/Down
- 22 OSD Button
- 23 Dolby Mode Selector
- 24 DTS Digital Mode Selector
- 25 Logic 7 Mode Select Button
- 26 Skip Up/Down Buttons
- 27 Transport Controls
- 28 Stereo Mode Select Button
- 29 DTS Neo:6 Mode Select
- 30 Macro Buttons
- 31 Disc Skip Button
- 32 Preset Up/Down
- 33 Clear Button
- 34 Memory Button
- 35 Delay/Prev. Ch.
- 36 Speaker Select
- 37 Multiroom Button
- 38 Volume Up/Down
- 39 TV/Video Selector
- 40 DMP ^{The Bridge} Selector
- 41 6-Channel/8-Channel Direct Input
- 42 Mute

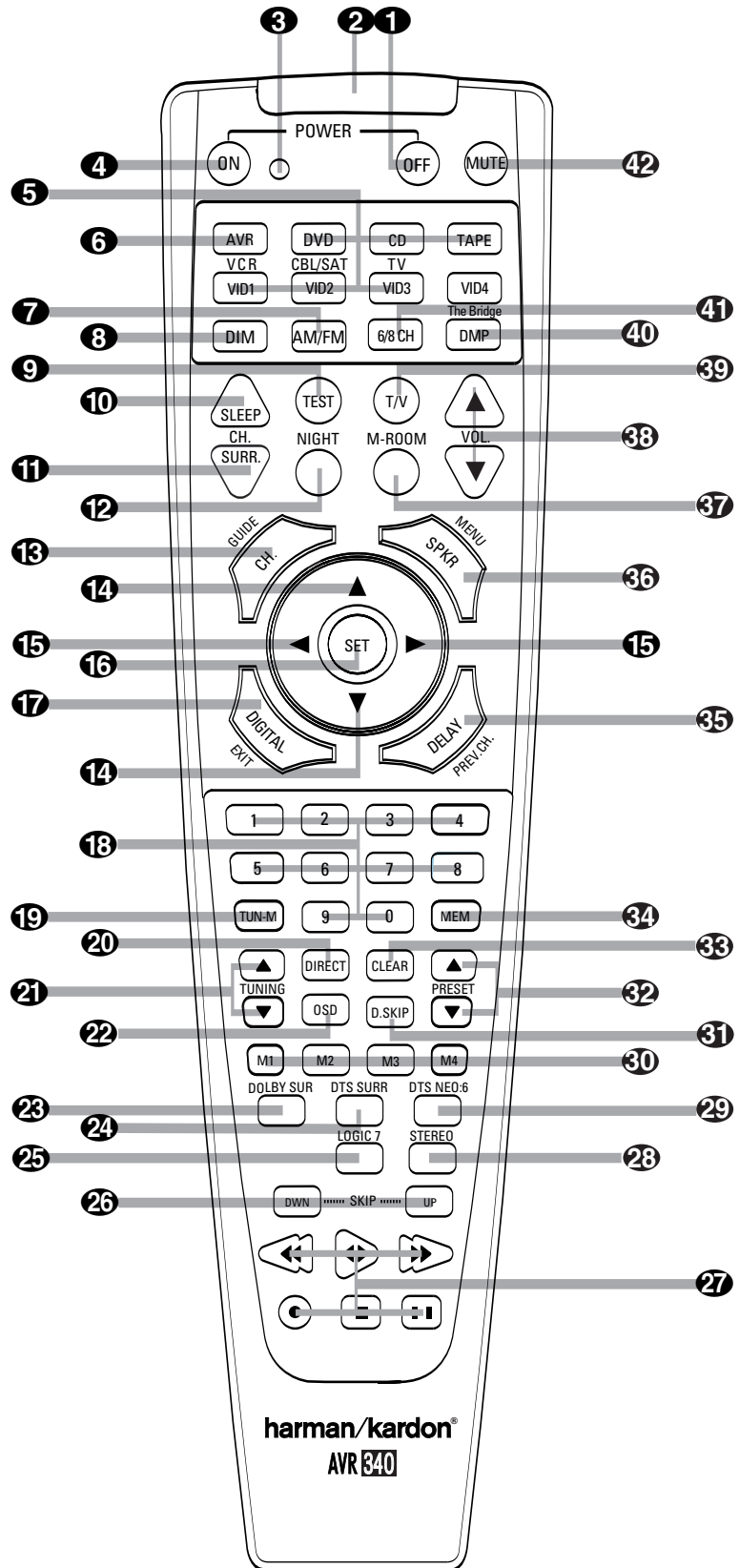

NOTES:

- The function names shown here are each button's feature when used with the AVR 340. Most buttons have additional functions when used with other devices. See pages 51–52 for a list of these functions.
- To make it easier to follow the instructions that refer to this illustration, a larger copy may be downloaded from the Product Support section for this product at www.harmankardon.com.

MAIN REMOTE CONTROL FUNCTIONS

IMPORTANT NOTE: The AVR 340's remote may be programmed to control up to seven devices, including the AVR 340. Before using the remote, it is important to remember to press the **Input Selector Button 5** that corresponds to the unit you wish to operate. In addition, the AVR 340's remote is shipped from the factory to operate the AVR 340 and most Harman Kardon CD or DVD players and cassette decks. The remote is also capable of operating a wide variety of other products using the control codes that are part of the remote. Before using the remote with other products, follow the instructions on page 48 to program the proper codes for the products in your system.

It is also important to remember that many of the buttons on the remote take on different functions, depending on the product selected using the Device Control Selectors. The descriptions shown here primarily detail the functions of the remote when it is used to operate the AVR 340. (See pages 49–52 for information about alternate functions for the remote's buttons.)

1 Power Off Button: Press this button to place the AVR 340 or a selected device in the Standby mode.

2 IR Transmitter Window: Point this window towards the AVR 340 when pressing buttons on the remote to make certain that infrared commands are properly received.

3 Program Indicator: This three-color indicator is used to guide you through the process of programming the remote. (See page 48 for information on programming the remote.)

4 Power On Button: Press this button to turn on the power to a device selected by pressing one of the **Input Selectors 5**.

5 Input Selectors: Pressing one of these buttons will perform three actions at the same time. First, if the AVR 340 is not turned on, this will power up the unit. Next, it will select the source shown on the button as the input to the AVR 340. Finally, it will change the remote control so that it controls the device selected. After pressing one of these buttons you must press the **AVR Selector Button 6** again to operate the AVR 340's functions with the remote.

6 AVR Selector: Pressing this button will switch the remote so that it will operate the AVR 340's functions. If the AVR 340 is in the Standby mode, it will also turn the AVR 340 on.

7 AM/FM Tuner Select: Press this button to select the AVR 340's tuner as the listening choice. Pressing this button when the tuner is already in use will select between the AM and FM bands.

8 Dim Button: Press this button to activate the Dimmer function, which reduces the brightness of the front panel display, or turns it off entirely. The first press of the button shows the default state, which is full brightness by indicating **VFD FULL** in the **Lower Display Line 27**. Press the button again within five seconds to reduce the brightness by 50%, as indicated by **VFD HALF** showing in the **Lower Display Line 27**. Press the button again within five seconds and the main display will go completely dark. Note that this setting is temporary, in that regardless of any changes, the display will always return to full brightness when the AVR is turned on. In addition, the **Power Indicator 2** will always remain at full brightness regardless of the setting. This is to remind you that the AVR is still turned on.

9 Test Button: Press this button to begin the sequence used to calibrate the AVR 340's output levels. (See pages 25, 31 and 42 for more information on calibrating the AVR 340.)

10 Sleep Button: Press this button to place the unit in the Sleep mode. After the time shown in the display, the AVR 340 will automatically go into the Standby mode. Each press of the button changes the time until turn-off in the following order:

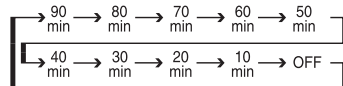

See page 34 for more information on the Sleep Function. This button is also used to change channels on your TV when the TV is selected.

11 DSP Surround Mode Selector: Press this button to cycle through the DSP, VMaX and Stereo surround modes such as Hall, Theater, VMaX Near and Far, and Surround Off. This button is also used to tune channels when the TV is selected using the device **Input Selector 5**.

12 Night Mode: Press this button to activate the Night mode. This mode is available in specially encoded digital sources, and it preserves dialogue (center channel) intelligibility at low volume levels.

13 Channel Select Button: This button is used to start the process of setting the AVR 340's output levels to an external source. Once this button is pressed, use the **▲/▼ Buttons 14** to select the channel being adjusted, then press the **Set Button 16**, followed by the **▲/▼ Buttons 14** again, to change the level setting. (See pages 31 and 42 for more information.) However, Harman Kardon recommends that you first perform the EzSet/EQ procedure, as described on pages 25 to 27.

14 ▲/▼ Buttons: These multipurpose buttons are used to change or scroll through items in the on-screen menus, make configuration settings such as digital inputs or delay timing, or to select surround modes. When changing a setting, first press the button for the function or setting to be changed (e.g., press the **DSP Surround Mode Selector 11** to select a sound field mode or the **Digital Select Button 17** to change a digital input) and then press one of these buttons to scroll through the list of options or to increase or decrease a setting. The sections in this manual describing the individual features and functions contain specific information on using these buttons for each application.

15 ◀/▶ Buttons: These buttons are used to change the menu selection or setting during some of the setup procedures for the AVR 340.

16 Set Button: This button is used to enter settings into the AVR 340's memory. It is also used in the setup procedures for delay time, speaker configuration and channel output level adjustment.

17 Digital Select: Press this button to assign one of the digital inputs **18 19 15 25** to a source. (See pages 22 and 38 for more information on using digital inputs.)

18 Numeric Keys: These buttons serve as a 10-button numeric keypad to enter tuner preset positions. They are also used to select channel numbers when TV, Cable or SAT has been selected on the remote, or to select track numbers on a CD, DVD or LD player, depending on how the remote has been programmed.

19 Tuner Mode: Press this button when the tuner is in use to select between automatic tuning and manual tuning. When the button is pressed so that **MANUAL** appears in the **Lower Display Line 27**, pressing the **Tuning Buttons 9 21** will move the frequency up or down in single-step increments. When the FM band is in use, pressing this button when a station's signal is weak will change to monaural reception. (See page 41 for more information.)

20 Direct Button: Press this button when the tuner is in use to start the sequence for direct entry of a station's frequency. After pressing the button, simply press the proper **Numeric Keys 18** to select a station. (See page 41 for more information on the tuner.)

MAIN REMOTE CONTROL FUNCTIONS

21 Tuning Up/Down: When the tuner is in use, these buttons will tune up or down through the selected frequency band. If the **Tuner Mode Button 19/17** has been pressed so that **AUTO** appears in the on-screen display and **Lower Display Line 27**, pressing and holding either of the buttons for three seconds will cause the tuner to seek the next station with acceptable signal strength for quality reception. When **MANUAL** appears in the **Lower Display Line 27**, pressing these buttons will tune stations in single-step increments. (See page 41 for more information.)

22 OSD Button: Press this button to activate the On-Screen Display (OSD) system used to set up or adjust the AVR 340's parameters.

23 Dolby Mode Selector: This button is used to select from among the available Dolby Surround processing modes. Each press of this button will select one of the Dolby Pro Logic II or IIx, or Dolby Virtual Speaker modes or Dolby 3 Stereo. When a Dolby Digital-encoded source is in use, the Dolby Digital mode may also be selected. When the headphones are in use, this button selects from among the Dolby Headphone modes. (See pages 36–37 and 40 for the available Dolby surround mode options.)

24 DTS Digital Mode Selector: When a DTS-encoded digital source is selected, each press of this button will scroll through the available DTS modes. The specific choice of modes will vary depending on whether the source material contains DTS-ES 6.1 Discrete encoding. When a DTS source is not in use, this button has no function. (See pages 36 and 40 for the available DTS digital options.)

25 Logic 7 Mode Select Button: Press this button to select from among the available Logic 7 surround modes. (See pages 36 and 40 for available Logic 7 options.)

26 Skip Up/Down Buttons: These buttons do not have a direct function with the AVR 340, but when used with a compatibly programmed CD or DVD changer they will change to the previous disc in the changer or carousel.

27 Transport Controls: These buttons do not have any functions for the AVR 340, but they may be programmed for the forward/reverse play operation of a wide variety of CD or DVD players, and audio or video cassette recorders. When the **DMP Bridge** source is in use, these buttons may be used to operate some functions on a compatible iPod if it is docked in The Bridge. See page 42 for more information on using **The Bridge**.

When the remote is used to control the AVR, or the VID2 or VID3 device, by default these buttons are programmed to operate the DVD player. However, you may use the Transport Control Punch-Through feature described on page 50 to program these buttons to operate another device's transport controls when the AVR, VID2 or VID3 has been selected.

28 Stereo Mode Select Button: When the button is pressed so that **SURROUND OFF** appears in the **Lower Display Line 27**, with only the **Surr Off Surround Mode Indicator 28** lit, the AVR will operate in a bypass mode with true, fully analog, two-channel left/right stereo mode with no surround processing or bass management, unlike other modes where digital processing is used. When the button is pressed so that **SURROUND OFF** appears in the **Lower Display Line 27**, with both the **DSP** and **Surr Off Surround Mode Indicators 28** lit, you may enjoy a two-channel presentation of the sound along with the benefits of bass management. Depending on whether your system is configured for 5.1 or 6.1/7.1 channels, the next press of the button will cause either **5 CH STEREO** or **7 CH STEREO** to appear, and the stereo signal will be routed to all five (or seven) speaker channels. (See pages 37 and 40 for more information on stereo playback modes.)

29 DTS Neo:6 Mode Select: Press this button to select a DTS Neo:6 mode. These modes take a two-channel stereo- or matrix surround-encoded source and create a full five-, six- or seven-channel sound field. (See pages 36 and 40 for the DTS Neo:6 options.)

30 Macro Buttons: Press these buttons to store or recall a "Macro," which is a preprogrammed sequence of commands stored in the remote. (See page 48 for more information on storing and recalling macros.)

31 Disc Skip Button: This button has no direct function for the AVR 340 but is most often used to change to the next disc in a CD or DVD player when the remote is programmed for that type of device. (See page 49 for more information on using the remote with products other than the AVR 340.)

32 Preset Up/Down: When the tuner is in use, press these buttons to scroll through the stations programmed into the AVR 340's memory. When some source devices, such as CD players, VCRs and cassette decks, are selected using the device **Input Selectors 5**, these buttons may function as Chapter Step or Track Advance.

33 Clear Button: Press this button to clear incorrect entries when using the remote to directly enter a radio station's frequency.

34 Memory Button: Press this button to enter a radio station into the AVR 340's preset memory. First, tune

the desired station, and then press this button. Two underline indicators will flash at the right side of the **Upper Display Line 26**, and within five seconds press the **Numeric Keys 18** for the preset number between 01 and 30 that you wish to assign to the station. (See page 41 for more information.)

35 Delay/Prev Ch.: Press this button to begin the process of setting the delay times used by the AVR 340 when processing surround sound. After pressing this button, the delay times are entered by pressing the **Set Button 16** and then using the **▲/▼ Buttons 14** to select **A/V SYNC DELAY** or the delay setting for any available channel. Press the **Set Button 16**, and then use the **▲/▼ Buttons 14** to change the setting. Press the **Set Button 16** again to complete the process. (See page 30 for more information.) However, we recommend that you first perform the EzSet/EQ procedure, as described on pages 25–27.

36 Speaker Select: Press this button to begin the process of configuring the AVR 340's bass management system for use with the type of speakers used in your system. Once the button has been pressed, use the **▲/▼ Buttons 14** to select the channel you wish to set up. Press the **Set Button 16** and then use the **▲/▼ Buttons 14** to select the appropriate speaker size. Press the **Set Button 16** to enter the new setting, and then use the **▲/▼ Buttons 14** again to select another channel to configure. When all adjustments have been completed, press the **Set Button 16** twice to exit the settings and return to normal operation. (See page 28 for more information.) However, Harman Kardon recommends that you first perform the EzSet/EQ procedure, as described on pages 25–27.

37 Multiroom Button: Press this button to begin the process of activating the multiroom system, or changing the source input or volume level for the remote zone. Press the **▲/▼ Buttons 14** to scroll to the on/off, source input or volume level setting, and then press the **Set Button 16** to access the desired setting. Use the **▲/▼ Buttons 14** to scroll through the options, and the **Set Button 16** to select. (See page 46 for information on the multiroom system.)

38 Volume Up/Down: Press these buttons to raise or lower the system volume. By default, the **Volume Up/Down Buttons 38** are programmed at the factory to control the AVR 340's volume, no matter which source device has been selected (except TAPE). You may reprogram these buttons to control the volume of another device, such as your TV, using the Volume Control Punch-Through instructions found on page 50.

39 TV/Video Selector: This button does not have a direct function on the AVR 340, but when used with a

MAIN REMOTE CONTROL FUNCTIONS

compatible VCR, DVD or satellite receiver, pressing this button will switch between the output of the device and the external video input. Consult the owner's manual for your specific player or receiver for the details of how it implements this function.

40 The Bridge Digital Media Player (DMP) Selector:

When Harman Kardon's The Bridge (optional) is connected to The Bridge Digital Media Player (DMP) Connector **29** and a compatible iPod is docked in The Bridge, pressing this selector will select the iPod as the audio source input device for the AVR 340. In addition, if a video display is connected to one of the Video Monitor Outputs **26/35**, the iPod's messages will appear on screen, and in the Upper and Lower Display Lines **26/27**. The ▲/▼/◀/▶ Buttons **14/15**, the Set Button **16** and the Transport Controls **27** may be used to navigate the iPod and to operate many functions. See page 42, and the manuals for The Bridge and your iPod for more information.

41 6-Channel/8-Channel Direct Input: Press this button to select the device connected to the 6/8-Channel Direct Inputs **34**. (See page 34 for more information.) When the device connected to the 6/8-Channel Direct Input **34** is also a video source, such as a DVD or DVD-Audio player with an onboard audio decoder, you must first select that video source by pressing one of the Input Selectors **5**, then press this button to choose the device connected to the 6/8-Channel Direct Input **34** as the audio source. Note that if you desire, you may select any video source to be used in conjunction with the 6/8-Channel Direct Input **34** as the audio source.

42 Mute: Press this button to momentarily silence the AVR 340 or TV set being controlled, depending on which device has been selected. When the AVR 340 remote is being programmed to operate another device, this button is pressed with the Input Selector Button **5** to begin the programming process. (See page 48 for more information on programming the remote.)

INSTALLATION AND CONNECTIONS

System Installation

After unpacking the unit, locating it in a place with adequate ventilation and placing it on a solid surface capable of supporting its weight, you will need to make the connections to your audio and video equipment.

IMPORTANT NOTE: For your personal safety and to avoid possible damage to your equipment and speakers, it is always a good practice to turn off and unplug the AVR and ALL source equipment from the AC output before making any audio or video system connections.

Audio Equipment Connections

We recommend that you use high-quality interconnect cables when making connections to source equipment and recorders to preserve the integrity of the signals.

1. Connect the analog outputs of a CD player to the **CD Audio Inputs** ④.

NOTE: When the CD player has both fixed and variable audio outputs, it is best to use the fixed output unless you find that the input to the receiver is so low that the sound is noisy, or so high that it is distorted.

2. Connect the analog Play/Out jacks of a cassette deck, MD, CD-R or other audio recorder to the **Tape Input Jacks** ⑫. Connect the analog Record/In jacks on the recorder to the **Tape Output Jacks** ⑬ on the AVR 340.
3. Connect the output of any digital sources such as a CD or DVD changer or player, advanced video game, a digital satellite receiver, HDTV tuner or digital cable set-top box or the output of a compatible computer sound card to the **Optical and Coaxial Digital Audio Inputs** ⑮⑲⑳㉑. We recommend connecting the coaxial digital audio output of your DVD player to the **Coax 1 Digital Audio Input** ㉑, since that digital input is assigned to the DVD source by default. The Video 2/Cable/Sat source defaults to the **Optical 1 Digital Audio Input** ⑮. If your cable television set-top box or satellite receiver is equipped with an optical digital audio output, we recommend that you connect it to this input to obtain the benefits of higher-quality digital audio (such as PCM, Dolby Digital 2.0 or Dolby Digital 5.1 signals when broadcast by your cable or satellite provider).

NOTE: If you wish for your digital source device to be available for use by the multiroom system, you will need to connect its analog audio outputs to the appropriate inputs on the AVR 340, as the multiroom system is not capable of distributing digital signals to the remote zone.

4. Connect the **Coaxial or Optical Digital Audio Outputs** ㉑㉒ on the rear panel of the AVR 340 to

the matching digital input connections on a CD-R or MiniDisc or other digital recorder.

5. Assemble the AM Loop Antenna supplied with the unit so that the tabs at the bottom of the antenna loop snap into the holes in the base. Connect it to the **AM Antenna Terminals** ④.

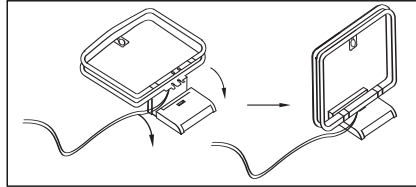

6. Connect the supplied FM antenna to the **FM** (75-ohm) **Connection** ①. The FM antenna may be an external roof antenna, an inside powered or wire-lead antenna or a connection from a cable TV system. If the antenna or connection uses 300-ohm twin-lead cable, you must use an optional 300-ohm-to-75-ohm adaptor to make the connection.
7. With the AVR 340 turned off, connect the optional Harman Kardon **Bridge** to **Bridge** **Digital Media Player (DMP) Connector** ㉔. Your compatible iPod may be docked in **Bridge** when you wish to use it as an audio source device. Video materials stored on the iPod may not be viewed through The Bridge.
8. Connect the front, center, surround and surround back speaker outputs ⑪⑫⑬⑭ to the respective speakers.

To ensure that all the audio signals are carried to your speakers without loss of clarity or resolution, we suggest that you use high-quality speaker cable. Many brands of cable are available and the choice of cable may be influenced by the distance between your speakers and the receiver, the type of speakers you use, personal preferences and other factors. Your dealer or installer is a valuable resource to consult in selecting the proper cable.

Regardless of the brand of cable selected, we recommend that you use a cable constructed of multistrand copper with a gauge of 14 or smaller. Remember that in specifying cable, the lower the number, the thicker the cable.

Cable with a gauge of 16 may be used for short runs of less than 10 feet. We do not recommend that you use cables with an AWG equivalent of 18 or higher, due to the power loss and degradation in performance that will occur.

Cables that are run inside walls should have the appropriate markings to indicate listing with UL, CSA or other appropriate testing agency standards. Questions about running cables inside walls should be referred to your

installer or a licensed electrician who is familiar with the NEC and/or the applicable local building codes in your area.

When connecting wires to the speakers, observe proper polarity. Note that the positive (+) terminal of each speaker connection may carry a specific color code, as noted on page 8. However, many speakers still use a red terminal for the positive (+) connection. Connect the "negative" or "black" wire to the same terminal on both the receiver and the speaker.

NOTE: While most speaker manufacturers adhere to an industry convention of using black terminals for negative and red ones for positive, some may vary from this configuration. To ensure proper phase and optimal performance, consult the identification plate on your speaker or the speaker's manual to verify polarity. If you do not know the polarity of your speaker, ask your dealer for advice before proceeding, or consult the speaker's manufacturer.

We also recommend that the length of cable used to connect speaker pairs be identical. For example, use the same length piece of cable to connect the front-left and front-right or surround-left and surround-right speakers, even if the speakers are a different distance from the AVR 340.

9. Connections to a subwoofer are normally made via a line-level audio connection from the **Subwoofer Output** ③ to the line-level input of a subwoofer with a built-in amplifier. When a passive subwoofer is used, the connection first goes to a power amplifier, which will be connected to one or more subwoofers. If you are using a powered subwoofer that does not have line-level input connections, follow the instructions furnished with the speaker for connection information.
10. If an external multichannel audio source with 5.1, 6.1 or 7.1 outputs such as an external digital processor/decoder, DVD-Audio or SACD player is used, connect the outputs of that device to the **6/8-Channel Direct Inputs** ㉓.

Video Equipment Connections

Video equipment is connected in the same manner as audio components. The use of high-quality interconnect cables is recommended to preserve signal quality.

1. Connect a VCR's, DVD recorder's, personal video recorder's or other video source's audio and video Play/Out jacks to the **Video 1 Audio/Video** and/or **S-Video Input Jacks** ㉖㉗ on the rear panel. The Audio and Video Record/In jacks on the recorder should be connected to the **Video 1 Audio/Video** and/or **S-Video Output Jacks** ㉘㉙ on the AVR 340. Although any video device may be connected to these jacks, we recommend connecting your video

INSTALLATION AND CONNECTIONS

recorder to take advantage of the fact that the remote control is preprogrammed with video recorder product codes for the Video 1 device.

2. Connect the analog audio and video outputs of a satellite receiver, cable TV converter, television set or any other video source to the **Video 2 Audio/Video and S-Video Input Jacks 31/39**. Although any video device may be connected to these jacks, we recommend connecting your cable TV converter or satellite receiver so that you may take advantage of the fact that the remote control is preprogrammed with the product codes of these device types for the Video 2 device.
3. Connect the analog audio and video outputs of a television or other video device to the **Video 3 Audio/Video and S-Video Input Jacks 33/41** on the rear panel. Although any video or audio device may be connected to these jacks, we recommend connecting your television so that you may take advantage of the fact that the remote control is preprogrammed with TV product codes for the Video 3 device.

Important: If you are using the television only as a display device (i.e., if you receive your TV programs through a cable box or satellite receiver), do not connect the television's outputs to the **Video 3 Audio/Video and S-Video Input Jacks 33/41**, or to any other inputs on the AVR 340.

4. Connect the analog audio and video outputs of a DVD or laser disc player to the **DVD Audio/Video and S-Video Inputs 27/35**.
5. Connect the digital audio outputs of a DVD player, satellite receiver, cable box or HDTV converter to the appropriate **Optical or Coaxial Digital Inputs 15/25/18/19**. Remember that the DVD source defaults to the **Coaxial 1 Digital Input 25**, and the Video 2/Cable/Sat source defaults to the **Optical 1 Digital Audio Input 15**. All other sources default to their analog inputs, although any source may be assigned to any digital audio input on the receiver.

NOTE: When connecting a device such as a digital cable box or other set-top tuner product with a digital audio output, we recommend that you connect both the digital and analog outputs of the product to your AVR. The audio input polling feature of the AVR will then be able to make certain that you have a constant audio feed, since it will automatically switch the audio input to the analog jacks if the digital feed is interrupted or not available for a particular channel.

6. Connect the **Video and/or S-Video Monitor Output 26/35** jacks on the receiver to the composite or S-video input of your analog television monitor or video projector.

7. If *both* your video display monitor and at least one video source device (such as a DVD player or HDTV set-top box) are equipped with component video capability, then you may connect the component video outputs of the device to one of the two **Component Video Inputs 17/18**. In that case, you will not need to connect the **Video Monitor Output 35** or the **S-Video Monitor Output 26** to your video display, as the AVR 340 will convert composite and S-video signals to component video. This means you only have to connect one cable from the AVR to the video display. You will also be able to view the AVR 340's on-screen displays using just the component video connection, unless the source device is high-definition (720p or 1080i) video, in which case you should either switch to a 480p source or connect the **Video Monitor Output 35** or the **S-Video Monitor Output 26** to your video display to view the on-screen displays.

It is recommended that you connect a DVD player or a digital video recorder to the **Component Video 1 Inputs 17**, as this input is assigned to the DVD, CD, Tuner and Tape sources by default. Thus, whenever any of these sources is selected, you may view the component video output of the device connected to the **Component Video 1 Inputs 17**, enabling you to view and listen to different sources.

Similarly, it is recommended that you connect any other audio/video device equipped with component video outputs, such as a DVD-Audio or SACD player, or HDTV set-top box, to the Video 1, Video 2 or Video 3 sources, or the 6-/8-channel direct inputs, as the **Component Video 2 Inputs 18** are assigned to the Video 1, Video 2, Video 3 and 6-/8-channel source audio inputs by default.

However, you may connect any component video source to either set of component video inputs, as they are assignable to any source, following the instructions on page 22. You will still need to connect either the analog or digital audio outputs, or the 6-/8-channel audio outputs, of your component video device to the analog audio inputs corresponding to the source (such as DVD or Video 2 for a cable converter box), or to any of the **Optical or Coaxial Digital Audio Inputs 15/25/18/19**.

8. If the component video inputs are used, connect the **Component Video Monitor Outputs 16** to the component video inputs of your TV, projector or display device. You will also be able to view your composite and S-video sources through this connection, benefiting from the higher quality and superior appearance of component video.
9. If you have a camcorder, video game or other audio/video device that is connected to the AVR on a temporary rather than permanent basis, connect

the audio, video and digital audio outputs of that device to the **Video 4 Inputs 18/19/20/21** on the front panel. A device connected here is selected as the Video 4 input, and the digital inputs must be assigned to the Video 4 input. (See page 22 for more information on input configuration.)

NOTE: The AVR 340 is shipped with two covers that may be installed over the front-panel input jacks when they are not in use.

10. When connecting the AVR 340 to a "digital-ready", "HDTV-compatible" or high-definition display (which is any device capable of accepting an input signal of 480p or higher), you are able to take advantage of the unit's advanced video processing circuitry which converts all video signals to a 480P output. Since the AVR 340 displays the on-screen menus with upconverted video, the connection from the AVR 340 to the display need only be one set of Y/Pr/Pb component video cables to the **Component Video Monitor Output 16**.
11. When connecting the AVR 340 to a standard, analog video display that has standard composite and S-video inputs only, component video inputs may not be used. In this case, connect the Video and **S-Video Monitor Outputs 26/35** to the matching composite and S-video inputs on your video display, depending on which types of video are used by your source devices. If both types of video are used by different source devices, than both **Video Monitor Outputs 26/35** must be separately connected to your television.

VIDEO CONNECTION NOTES:

- When the component video jacks are used, the on-screen menus are not visible with high-definition video (720p or 1080i), and you must switch to the standard composite or S-video input on your TV, or to a 480p video source, to view them.
- When source devices such as a progressive scan DVD player or an HDTV set-top box are connected to the AVR 340 via component video connections, if you wish to take advantage of the record outputs or have video routed to a second room, it is also necessary to connect the standard, composite or S-video outputs of the source device to the AVR 340. The record outputs and multiroom system cannot accept component inputs, nor are component inputs down-converted for use with these outputs.
- When connecting a video source to the AVR 340, you may use either composite, component or S-video, but only one type of video may be connected for each device.

INSTALLATION AND CONNECTIONS

System and Power Connections

The AVR 340 is designed for flexible use with multi-room system and external control components.

Remote Infrared (IR) Control of the AVR or Source Devices

If the receiver is placed behind a solid or smoked glass cabinet door, the obstruction may prevent the remote sensor from receiving commands. In this event, an optional remote sensor may be used. Connect the output of the remote sensor to the **Remote IR Input** ⑨ jack.

If other components are also prevented from receiving remote commands, only one sensor is needed. Simply use this unit's sensor or a remote eye by running a connection from the **Remote IR Output** ⑩ jack to the Remote IR Input jack on Harman Kardon or other compatible equipment.

When controlling non-Harman Kardon source devices, the device may require the full carrier signal embedded within the IR command, rather than the "stripped" signal used by Harman Kardon and many other devices. In these cases you may need to connect the **Remote IR Carrier Output** ⑥ to the remote IR input of your device (or to an optional, external IR "blaster"), rather than using the standard **Remote IR Output Jack** ⑩. If you are in doubt as to which IR Output jack to use for the equipment in your system, contact your dealer or installer, or the manufacturer's support site and ask whether the unit to be controlled uses "full carrier" or "stripped carrier" IR commands. When "full carrier commands" are used, make the connection to the **Remote IR Carrier Output** ⑥. Otherwise, make the connection to the **Remote IR Output Jack** ⑩.

NOTE: All remotely controlled components must be linked together in a "daisy chain." Connect the IR OUT jack of one unit to the IR IN of the next to establish this chain.

Multiroom Connections

The AVR 340 is equipped with multizone capabilities that allow it to send a separate audio source to the remote zone from the one selected for use in the main room.

Depending on your system's requirement, three options are available for audio connection:

Option 1: Use high-quality, shielded audio interconnect cable from the AVR 340's location to the remote room. In the remote room, connect the interconnect cable to a stereo power amplifier. The amplifier will be connected to the room's speakers. At the AVR 340, plug the audio interconnect cables into the **Multiroom Audio Outputs** ② on the AVR 340's rear panel.

Option 2: Connect the Multiroom Audio Outputs

② on the AVR 340 to the inputs of an optional stereo power amplifier. Run high-quality speaker wire from the amplifier to the speakers in the remote room.

Option 3: Taking advantage of the AVR 340's built-in seven-channel amplifier, it is possible to use two of the amplifier channels to power speakers in the remote room. When using this option, you will not be able to use the full 7.1-channel capabilities of the AVR 340 in the main listening room, but you will be able to add another listening room without external power amplifiers. To use the internal amplifiers to power a remote zone, connect the speakers for the remote room location to the **Surround Back/Multiroom Speaker Outputs** ①. Before using the remote room, you will need to configure the amplifiers for surround operation by changing a setting in the **MULTI ROOM SETUP** menu, following the instructions shown on page 46.

NOTE: The AVR 340's multiroom system is only capable of distributing analog audio sources to the remote zone. Therefore, when connecting your digital audio equipment (e.g. CD or DVD players) as described on page 16, make sure to use both analog and digital audio connections to ensure that the devices will be available to the multiroom system.

IR Control From the Remote Room

For all options, you may connect an optional IR sensor in the remote room to the AVR 340 via an appropriate cable. Connect the sensor's cable to the **Multiroom IR Input** ⑤ on the AVR 340 and use the Zone II (or main) remote to control the room volume and any source devices connected to the **Remote IR Output Jack** ⑩ or to the **Remote IR Carrier Output Jack** ⑥ as described above. Alternatively, you may install an optional volume control between the output of the amplifiers and the speakers, which will only enable you to adjust the volume of playback in the remote room.

A-BUS® Installation Connections

The AVR 340 is among the few receivers available that offer built-in A-BUS/READY operation. When used with an optional A-BUS product, you have all the benefits of remote zone operation without the need for an external power amplifier.

To use the AVR 340 with an approved A-BUS product, simply connect it to the AVR 340 using Category 5 wiring that is properly rated for the specific in-wall installation. Terminate the wiring at the receiver end to a standard RJ-45 connector in compliance with the instructions furnished with the A-BUS product.

You may connect a single A-BUS module to the AVR 340 with no further equipment needed. If you wish to connect more than one A-BUS module, an optional, external A-BUS hub may be used to provide that capability.

Contact your dealer or visit www.harmankardon.com for more information on other A-BUS products available from Harman Kardon. No further installation or adjustment is needed, as the A-BUS jack on the AVR 340 routes the signals to their proper destination. The output fed to the A-BUS jack is determined by the AVR 340's multiroom system and menus.

If the A-BUS module is equipped with an IR sensor, you may use the Zone II or main remote to control the room volume and any source devices connected to the **Remote IR Output Jack** ⑩ or to the **Remote IR Carrier Output Jack** ⑥ as described above.

AC Power Connections

This unit is equipped with two accessory AC outlets. They may be used to power accessory devices, but they should not be used with high-current-draw equipment such as power amplifiers. The total power draw to each outlet may not exceed 100 watts.

The **Switched AC Accessory Outlet** ⑳ will receive power only when the unit is on. This is recommended for devices that have no power switch or a mechanical power switch that may be left in the "ON" position.

NOTE: Many audio and video products go into a Standby mode when they are used with switched outlets, and cannot be fully turned on using the outlet alone without a remote control command.

The **Unswitched AC Accessory Outlet** ㉑ will receive power as long as the unit is plugged into a powered AC outlet.

Once the **AC Power Cord** ㉒ is connected, you are almost ready to enjoy the AVR 340's incredible power and fidelity!

OPERATION

Basic Operation

Once you have completed the initial setup and configuration of the AVR 340, it is simple to operate and enjoy. The following instructions will help you maximize the enjoyment of your new receiver:

Turning the AVR 340 On or Off

- When using the AVR 340 for the first time, you must first press the **Main Power Switch 1** on the front panel to turn the unit on. This places the unit in a Standby mode, as indicated by the amber color of the **Power Indicator 2**. Once the unit is in Standby, you may begin a listening session by pressing the **Standby/On Switch 3** on the front panel, or the **Power On Button 4** or **AVR Selector 6 B** on the remote. The **Power Indicator 2** will turn blue. This will turn the unit on and return it to the input source that was last used. The unit may also be turned on from Standby by pressing any of the **Input Selector Buttons 5 7 40 41 C D** on the remote or the **Input Source Selector Button 16** on the front panel.

Whenever the AVR is turned on, you will see all of the front-panel indicators light up for a few seconds. This is normal, and it is part of the unit's power-on self test procedure.

NOTE: After pressing one of the **Input Selector Buttons 5 7 40 41 C D** to turn the unit on, press the **AVR Selector 6 B** to set the remote control to the AVR 340 functions.

To turn the unit off at the end of a listening session, simply press the **Standby/On Switch 3** on the front panel or the **Power Off Button 1 A** on the remote. Power will be shut off to any equipment plugged into the rear-panel **Switched AC Accessory Outlet 14** and the **Power Indicator 2** will turn amber.

When the remote is used to turn the unit "off" it is actually placing the system in a Standby mode, as indicated by the amber color of the **Power Indicator 2**.

- To program the AVR 340 for automatic turn-off, press the **Sleep Button 10** on the remote. Each press of the button will decrease the time before shut-down in the following sequence:

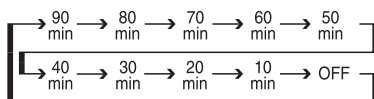

The sleep time will be displayed in the **Lower Display Line 27**. The front-panel display will dim to one-half brightness when the Sleep function is programmed. To view the current sleep time when the sleep function has been activated, press the **Sleep Button 10** once. The display will return to normal brightness, and the time until shutdown will

appear in the **Lower Display Line 27**. After a few seconds, the message will disappear and the display will return to half-brightness.

When the programmed sleep time has elapsed, the unit will automatically turn off. To cancel the Sleep function, press and hold the **Sleep Button 10** as the information display returns to normal brightness; continue to hold the button until the Sleep indicator numbers disappear and the words **SLEEP OFF** appear in the **Lower Display Line 27**.

When you will be away from home for an extended period of time it is always a good idea to completely turn the unit off with the front-panel **Main Power Switch 1**.

NOTE: All preset memories are lost if the unit is left turned off by using the **Main Power Switch 1** for more than four weeks.

Source Selection

- To select a source, press any of the **Input Selector Buttons 5 7 40 41 C D** on the remote.
- The input source may also be changed by pressing the front-panel **Input Source Selector Button 16**. Each press of the button will move the input selection through the list of available inputs.
- As the input is changed, the AVR 340 will automatically switch to the digital input (if selected), component video input, surround mode, output levels and night mode status as well as any speaker configuration settings established by using the **INDEPENDENT** Bass Management setting, that were entered during the configuration process for that source.
- When the input source is changed, the new input name and the digital (or analog) audio input will appear in the **Upper Display Line 26**, and the current surround mode will appear in the **Lower Display Line 27**. The same messages will also appear momentarily in the on-screen display in the lower third of the screen (semi-OSD).
- When an audio source is selected, the last video input used remains routed to the **Video 1 Video and S-Video Outputs 30 39** and **Component Video, Composite Video and S-Video Monitor Outputs 16 26 35**. This permits you to simultaneously view and listen to different sources. This also allows you to choose a video source and then select the **6/8-Channel Direct Inputs 34** as the audio source. Thanks to the AVR 340's cross-conversion capability, composite and S-video sources are upconverted and routed to the **Component Video Monitor**

Outputs 16, and they may be viewed on a video display with component video inputs.

- The front-panel **Video 4 Inputs 20 21**, **Optical 3 Digital Input 18** or the **Coaxial 3 Digital Input 19** may be used to connect a device such as a video game or camcorder to your home entertainment system on a temporary basis. When the front-panel jacks are not in use, you may prefer to install the covers supplied with your receiver for a neater appearance. Simply snap them in place. If you wish to use the jacks, press on the left side of each cover to pivot it and remove.
- When DMP **Bridge** is selected as the source and a compatible iPod is inserted in an optional Harman Kardon **Bridge** that is connected to **Bridge** **DMP Connector 29** on the rear panel, navigation messages will appear on any video display connected to the AVR's **Video Monitor Outputs 26 35**. The remote control or front-panel controls may be used to navigate the iPod and access many of its functions. These messages will also appear in the front-panel display, and the iPod's battery may be charged. See the owner's guides for **Bridge** and your iPod for more information.

6-Channel/8-Channel Direct Input

- There are two input choices available for use with sources such as a DVD-Audio or SACD player that are connected to the **6/8-Channel Direct Inputs 34**. Select the appropriate input according to the way your system and source equipment are configured:
 - 6 CH DIRECT** should be used when the SBR and SBL inputs are NOT in use. It is assumed that the input source device has its own internal bass management system. This input passes the input from the source directly through to the volume control without any analog to digital conversion and it mutes the unused input jacks to prevent unwanted noise from interfering with system performance.
 - 8 CH DIRECT** should be used when an input is connected to all eight **8-Channel Direct Inputs 29**. It is assumed that the input source device has its own internal bass management system. This input passes the input from the source directly through to the volume control without any analog-to-digital conversion and it mutes the unused input jacks to prevent unwanted noise from interfering with system performance.

Volume and Tone Control

- Adjust the volume to a comfortable level using the front-panel **Volume Control 23** or remote **Volume Up/Down Buttons 38 G**.

- To temporarily silence all speaker outputs, press the **Mute Button 42**. This will interrupt the output to all speakers and the headphone jack, but it will not affect any recording or dubbing that may be in progress. When the system is muted, the word **MUTE** will flash in the **Upper Display Line 26**. Press the **Mute Button 42** again to return to normal operation.
- You may adjust the bass and treble tone controls at any point during a listening session by pressing the **Tone Mode Button 5** until **TONE IN** appears in the **Lower Display Line 27**. Press the **Tone Mode Button 5** again until either **TREBLE MODE** or **BASS MODE** appears in the **Lower Display Line 27**, and then use the **Buttons 10** to boost or cut the low or high frequencies by up to ± 10 dB, in 2dB steps, until the desired setting is achieved.
- You may also totally remove the tone controls from the circuit so that the output is "flat" at any time by pressing the **Tone Mode Button 5** and then pressing the **Buttons 10** so that **TONE OUT** appears in the on-screen display and the **Lower Display Line 27**.
- The tone controls may also be adjusted using the **AUDIO SETUP** submenu as described on page 23.
- For private listening, plug the 1/4" stereo phone plug from a pair of stereo headphones into the front-panel **Headphone Jack 4**. When the headphone plug is connected, all speakers will be muted and **DOLBY H:BP** will appear in the **Lower Display Line 27**, indicating that the headphone output is in the Bypass mode, and to confirm that no processing is being used. When the headphone plug is removed, the audio feed to the speakers will be restored.
- When the headphones are in use, you may take advantage of the Dolby Headphone modes to bring added spaciousness to headphone listening. Press the **Dolby Mode Select Button 23** or the **Surround Mode Group Selector 7** to cycle through the three Dolby Headphone modes and select the one that you prefer.

Surround Mode Selection

One of the important features of the AVR 340 is its ability to reproduce a full multichannel surround sound field from digital sources, analog matrix surround-encoded programs and standard stereo programs.

Selection of a surround mode is based on personal taste, as well as the type of program source material being used. For example, motion pictures or TV programs bearing the logo of one of the major surround-

encoding processes, such as Dolby Surround or DTS Stereo, may be played in either the Dolby Digital, Dolby Pro Logic II or IIx Movie, DTS Neo:6 Cinema, or Logic 7 5.1 or 7.1 Cinema surround modes.

NOTE: Once a program has been encoded with matrix surround information, it retains the surround information as long as the program is broadcast in stereo. Thus, movies with surround sound may be decoded via any of the analog surround modes such as Dolby Pro Logic IIx-Movie, Logic 7 Cinema or DTS Neo:6 Cinema, when they are broadcast via conventional TV stations, cable, pay-TV and satellite transmission. In addition, a growing number of made-for-television programs, sports broadcasts, radio dramas and music CDs are also recorded in surround sound.

Even when a program is not listed as carrying intentional surround information, you may find that the Dolby Pro Logic IIx, Logic 7 or DTS Neo:6, VMAx and the Hall or Theater modes often deliver enveloping surround presentations through the use of the natural information present in all stereo recordings.

Surround modes may be changed at any time by using either the front panel or remote control. Any changes made to the surround mode for that source will be retained in the AVR's menu, even after another source is selected, or if the AVR is placed in Standby mode. To select a new surround mode from the front panel, first press the **Surround Mode Group Selector Button 7** until the desired major surround mode group, such as Dolby, DTS or Logic 7, is selected. Next, press the **Surround Mode Selector Button 8** to choose the specific individual surround mode.

To select a surround mode using the remote, press the button for the major surround mode group that includes the mode you wish to choose from: **Dolby 23**, **DTS Surround 24**, **DTS Neo:6 29**, **Logic 7 25**, **Stereo 28** or **DSP Surround 11**. The first press of the button will show the current mode from that group. To cycle through the available modes in that group, press the button again until the desired mode appears in the **Lower Display Line 27**, the on-screen display and in the **Surround Mode Indicators 28**. As the surround mode changes, the appropriate **Surround Mode Indicator 28** will light to indicate the current mode.

At times, it is possible that more than one indicator will light. This can occur when the DSP Surround Off mode has been selected, or when post-processing is being used with an input signal, such as when the Dolby Digital 2.0 plus Dolby Pro Logic IIx mode is used to create a 7-channel presentation of a two-channel signal.

The Dolby Digital, Dolby Digital EX and DTS 5.1, DTS-ES Matrix and DTS-ES Discrete modes may only

be selected when a digital input is in use and a digital signal in that format is present. In addition, when a digital source is present, the AVR 340 will automatically select and switch to the correct mode, regardless of the mode that has been previously selected. For more information on selecting digital sources, see the Digital Audio Playback section.

The Dolby Pro Logic IIx modes are available only when the AVR 340 has been configured for 6.1/7.1 operation by setting the Surround Back speakers as either **LARGE** or **SMALL** as described on page 28. These modes provide a matrixed 6.1-channel presentation of analog sources.

When the 6-channel/8-channel direct inputs are in use there is no surround processing, as these inputs take the analog output signals from an optional, external DVD-Audio or SACD player, or another source device and carry them straight through to the volume control without any further digital processing.

To listen to a program in traditional two-channel stereo, using the front left and front right speakers only (plus the subwoofer, if installed and configured), press the **Stereo Button 28** until **SURROUND OFF** appears in the **Lower Display Line 27**, or press the **Surround Mode Group Selector 7** until the Stereo modes appear in the on-screen display and **Lower Display Line 27** and then press the **Surround Mode Select Button 8** until **SURROUND OFF** appears in the on-screen display and **Lower Display Line 27**.

When an analog audio source is in use, you may activate an analog bypass Surround Off mode, if you have removed the tone controls from the processing circuitry. This is done by pressing the **Tone Mode Button 5** and using the **Buttons 10** until the **TONE OUT** message appears in the **Lower Display Line 27**, or using the **AUDIO SETUP** menu.

If the tone controls are active (**TONE IN**), or if you have selected the digitized Surround Off mode, the DSP icon will appear in the **Surround Mode Indicators 28**, and the message **SURROUND OFF** will appear in the lower line of the semi-OSD display. The DSP icon indicates that the incoming signal is being digitized and any bass management settings are being applied. This mode is recommended when your front speakers are not capable of reproducing the lower frequencies and are thus used with a subwoofer.

When the DSP icon is not lit in Surround Off mode with an analog audio input in use, the AVR is in analog bypass mode. The signal is being routed directly to the volume control, without entering the digital domain and without any bass management settings being applied. This mode is desirable when your left and right speak-

OPERATION

ers are capable of reproducing low frequencies, and when you wish to hear the analog source material in its pure form.

Digital Audio Playback

Digital audio is a major advancement over older analog surround processing systems. It delivers five, six or seven discrete channels: left front, center, right front, left surround, right surround and optionally one or two surround back channels. Each channel reproduces full frequency range (20Hz to 20kHz) and offers dramatically improved dynamic range and significant improvements to signal-to-noise ratios. In addition, digital systems have the capability to deliver an additional channel that is specifically devoted to low-frequency information. This is the ".1" channel referred to when you see these systems described as "5.1," "6.1" or "7.1". The bass channel is separate from the other channels, but since it is intentionally bandwidth-limited, sound designers have given it that unique designation.

Dolby Digital

Dolby Digital is a standard part of DVD, and is available on specially encoded LD discs and satellite broadcasts and it is a part of the high-definition television (HDTV) system.

An optional, external RF demodulator is required to use the AVR 340 to listen to the Dolby Digital soundtracks available on laser discs. Connect the RF output of the LD player to the demodulator and then connect the digital output of the demodulator to the **Optical or Coaxial Inputs 18 19 15 25** of the AVR 340. No demodulator is required for use with DVD players or DTS-encoded laser discs.

DTS

DTS is another digital audio system that is capable of delivering 5.1 or 6.1 discrete or matrix sound field reproduction. Although both DTS and Dolby Digital are digital, they use different methods of encoding the signals, and thus they require different decoding circuits to convert the digital signals back to analog.

DTS-encoded soundtracks are available on select DVD and LD discs, as well as on special audio-only DTS discs. You may use any LD or CD player equipped with a digital output to play DTS-encoded discs with the AVR 340. All that is required is to connect the player's output to either an **Optical or Coaxial Input** on the rear panel **15 25** or front panel **18 19**.

In order to listen to DVDs encoded with DTS soundtracks, the DVD player must be compatible with the DTS signal as indicated by a DTS logo on the player's front panel. Early DVD players may not be able to play DTS-encoded DVDs. This does not indicate a problem with the AVR 340, as some players cannot pass the DTS signal through to the digital outputs. If you are in

doubt as to the capability of your DVD player to handle DTS discs, consult the player's owner's manual.

IMPORTANT NOTE: Many DVD players have a default setting that does not pass through the DTS data, even though the machine is capable of doing so. If your DVD player has the "DTS Digital Out" logo but does not trigger DTS playback in the AVR 340, change the player's settings in the "Audio" or "Bitstream" configuration menu so that DTS playback is enabled. The method for doing this will vary with each player. In some cases, the proper menu choice will be "Original," while in others it will be "DTS." Consult the owner's manual for your player to find the specific information to find the proper setting.

Selecting a Digital Source

To utilize either digital mode, you must have properly connected a digital source to the AVR 340. Connect the digital outputs from DVD players, HDTV receivers, satellite systems or CD players to the **Optical or Coaxial Inputs 18 19 15 25**. In order to provide a backup signal and a source for analog stereo recording, the analog outputs provided on digital source equipment should also be connected to their appropriate inputs on the AVR 340 rear panel (e.g., connect the analog stereo audio output from a DVD to the **DVD Audio Inputs 46** on the rear panel when you connect the source's digital outputs).

If you have not already configured an input for a digital source using the on-screen menus as shown on page 22, first select the input using the remote or front-panel controls as outlined in this manual. Next, select the digital source by pressing the **Digital Select Button 17 13** and then using the **▲/▼ Buttons 14** on the remote or the **◀▶ Buttons 10** on the front panel to choose any of the **OPTICAL** or **COAXIAL** inputs, as they appear in the **Upper Display Line 26** or on-screen display. When the digital source is playing, the AVR 340 will automatically detect which type of digital data stream is being decoded and display that information in the **Upper Display Line 26**.

The AVR 340's Auto Polling feature searches both the digital and analog audio inputs assigned to a source for an incoming signal. Although the digital input is the default, if the digital stream is not present or is interrupted, the unit will automatically switch over to the analog inputs. If you wish to disable the auto-polling feature for any source, follow the instructions shown in the Input Setup section of this manual on page 23.

Digital Bitstream Indications

When a digital source is playing, the AVR 340 senses the type of bitstream data that is present. Using this information, the correct surround mode will automatically be selected. For example, DTS bitstreams will cause the unit to switch to DTS decoding, and Dolby Digital bitstreams will enable Dolby Digital decoding.

When the unit senses PCM data from CDs or LDs, it will default to Logic 7 Music mode, although you may select any of the standard surround modes, such as Dolby Pro Logic II or Logic 7. Since the range of available surround modes is dependent on the type of digital data that is present, the AVR 340 uses a variety of indicators and messages to let you know what type of signal is present. These messages will appear shortly after an input or surround mode is changed, and they will remain in the **Lower Display Line 27** for about five seconds before that portion of the display returns to the normal surround mode indication.

Surround Mode Channel Indications

For Dolby Digital and DTS sources, a three-digit indication will appear, showing the number of channels present in the data. An example of this type of display is **3/2/.1**.

The first number indicates how many discrete front channel signals are present.

- A "3" tells you that separate front left, center and front right signals are available. This will be displayed for Dolby Digital 5.1 and DTS 5.1 programs.
- A "2" tells you that separate front left and right signals are available, but there is no discrete center channel signal. This will be displayed for bitstreams that have stereo program material.
- A "1" tells you that there is only a mono channel available in the bitstream.

The middle number indicates how many discrete surround channel signals are present.

- A "2" tells you that separate surround left and right signals are available. This will be displayed for Dolby Digital 5.1 and DTS 5.1 programs.
- A "1" tells you that there is only a single, surround-encoded surround channel. This will appear for Dolby Digital bitstreams that have matrix encoding.
- A "0" indicates that there is no surround channel information. This will be displayed for 2-channel stereo programs.

The last number indicates whether there is a discrete low-frequency effects (LFE) channel. This is the ".1" in the common abbreviation of "5.1" sound and is a special channel that contains only bass frequencies.

- A "1" tells you that an LFE channel is present. This will be displayed for Dolby Digital and DTS programs, as available.
- A "0" indicates that there is no LFE channel information available. However, even when there is no dedicated LFE channel, low-frequency sound will be present at the subwoofer output when the speaker configuration is set to show the presence of a subwoofer.

The information in the right side of the display will tell you if the digital audio data contains a special flag signal that will automatically activate the appropriate 6.1 or 7.1 mode. This will be shown as **EX-ON** or **EX-OFF** for Dolby Digital bitstreams and **ES-ON** or **ES-OFF** for DTS bitstreams.

If the EX flag is off, and your receiver has been configured for 6.1/7.1 operation, you may manually turn on EX processing as appropriate by simply selecting the Dolby Digital EX surround mode as described on pages 23 and 35. When the ES flag is not present in a DTS bitstream, you may benefit from a 6.1-channel presentation by selecting the DTS+Neo:6 post-processing surround mode using the procedure described on pages 23 and 35. In that mode, the DTS Neo:6 algorithms will be used to derive the surround back channel from the DTS bitstream information.

Surround Mode Post Processing

Thanks to the power of the AVR 340's DSP processor, a variety of surround mode options are available for most digital signals to deliver either the native information or to produce an enhanced sound field to match the number of speakers in your system. The modes available and the number of channels available for each mode will vary depending on the incoming bitstream, and the configuration of your system, and are listed in the tables on page 40. The modes may be selected in the usual manner by selecting the major Surround Mode Group first, and then scrolling through the options (see pages 23 and 35).

The incoming bitstreams are indicated in the **Lower Display Line 27** as described above. After you have selected a surround mode, after about 5 seconds, the bitstream will be displayed briefly before the unit returns to normal operation. Therefore, you may ascertain the current bitstream by pressing the button for the major Surround Mode Group and waiting for a few moments for the bitstream to appear in the **Lower Display Line 27**. The bitstream information will also be displayed after the source input has been changed.

To use the tables on page 40, match the indication in the display to the Incoming Bitstream listed in the left column. The available surround modes are shown to the right.

See page 45 for information on setting the system to use a surround mode that you select by referring to these tables, rather than the default digital mode.

It is always a good idea to check the readout for the channel data to make certain that it matches the audio logo information shown on the back of a DVD package. In some cases you will see indication for "2/0/0" even when the disc contains a full 5.1, or 3/2/1 signal. When this happens, check the audio output settings for your DVD player or the audio menu selections for the specific disc being played to make certain that the player is sending the correct signal to the AVR.

PCM Audio Playback

PCM is the abbreviation for Pulse Code Modulation, which is the type of digital signal used for standard CD playback and other non-Dolby Digital and non-DTS digital sources such as Mini-Disc. The digital circuits in the AVR 340 are capable of high-quality digital-to-analog decoding, and they may be connected directly to the digital audio output of your CD or LD player.

Connections may be made to either the rear-panel **Optical or Coaxial Inputs 15/25** or the front-panel **Digital Inputs 18/19**.

To listen to a PCM digital source, first select the input for the desired source (e.g., CD). Next press the **Digital Select Button 13/17** and then use the **▲/▼ Buttons 14** on the remote, or the **◀/▶ Selector Buttons 10** on the front panel, until the desired choice appears in the **Upper Display Line 26**.

During PCM playback, you may select any Surround mode except Dolby Digital or DTS, as shown in the table on page 40. Note that for convenience, we have included the modes available for analog sources (including the tuner) in this chart.

When a PCM signal is detected, the **Lower Display Line 27** will briefly show a message with the letters PCM, in addition to a readout of the sampling frequency of the digital signal. In most cases, this will be **44.1kHz** or **48kHz**, though in the case of specially mastered, high-resolution audio discs you will see a **96kHz** indication.

Speaker/Channel Indicators

In addition to the bitstream indicators, the AVR 340 features a set of unique channel-input indicators that tell you how many channels of digital information are being received and/or whether the digital signal is interrupted (Figure 16).

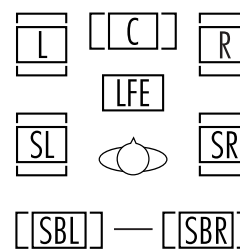

Figure 16

The letters inside the boxes tell you which channels are receiving an input signal. Since conventional analog audio is only two channels, the "L" and "R" letters will light with any analog source. When a digital source is in use you will see letters displayed that correspond to the number of channels in the incoming data stream, which may be just the L and R for two channel PCM or 2.0 Dolby Digital material. When a 5.1 signal is being received the L/C/R/SL/SR indicators will light, with the LFE indication also being shown when an LFE signal is present. All seven indicators, including the SBL/SBR letters will light for a 7.1 signal, and a horizontal line is shown to connect the SBL/SBR indicators when a 6.1 source is in use.

It is important to note that although Dolby Digital, for example, is referred to as a "5.1" system, not all Dolby Digital DVDs or programs are encoded for 5.1. Thus, it is sometimes normal for a DVD with a Dolby Digital soundtrack to trigger only the "L" and "R" indicators.

NOTE: Many DVD discs are recorded with both "5.1" and "2.0" versions of the same soundtrack. When playing a DVD, always be certain to check the type of material on the disc. Most discs show this information in the form of a listing or icon on the back of the disc jacket. When a disc does offer multiple soundtrack choices, you may have to make some adjustments to your DVD player (usually with the "Audio Select" button or in a menu screen on the disc) to send a full 5.1 feed to the AVR 340. It is also possible for the type of signal feed to change during the course of a DVD's playback. In some cases, the previews of special material will only be recorded in 2.0 audio, while the main feature is available in 5.1 audio. The AVR 340 will automatically sense changes to the bitstream and channel count and reflect them in these indicators.

The letters used by the **Speaker/Channel Input Indicators 25** will flash to indicate when a bitstream has been interrupted. This will happen when a digital input source is selected before the playback starts, or when a digital source such as a DVD is paused. The flashing indicators remind you that the playback has stopped due to the absence of a digital signal and not through any fault of the AVR 340. This is normal, and the digital playback will resume once the playback is started again.

(Cont. on page 41)

The boxes around the channel indication letters are used to show which speakers are configured in your system. A small box around the letter indicates that a "Small" speaker has been assigned to that position, while a larger, double box indicates a "Large" speaker assignment.

Note that in some cases, such as an analog stereo or 2.0 digital source you will see empty speaker position boxes, which indicates that the speaker is active and will receive sound, but that there is no discrete signal for that channel. In other cases you may see letters with no speaker boxes. This indicates that there is a discrete signal for that channel, but due to the mode in use (e.g., Dolby VS with a 5.1 source) there is no signal being sent to the channel.

Night Mode

A special feature of Dolby Digital is the Night mode, which enables specially encoded Dolby Digital input sources to be played back with full digital intelligibility while reducing the minimum peak level by 1/4 to 1/3. This prevents abruptly loud transitions from disturbing others, without reducing the impact of the digital source. The Night mode is available only when Dolby Digital signals with special data are being played.

The Night mode may be engaged when a Dolby Digital DVD is playing by pressing the **Night Mode Button 12** on the remote. Next, press the **▲/▼ Buttons 14** to select either the middle-range or full-compression versions of the Night mode. To turn the Night mode off, press the **▲/▼ Buttons 14** until the message in the lower third of the video display and in the **Lower Display Line 27** reads **D - RANGE OFF**.

The Night mode may also be selected to always be on at either level of compression using the options in the **DOLBY** menu. See page 24 for information on using the menus to set this option.

IMPORTANT NOTES ON DIGITAL PLAYBACK:

- When the digital playback source is stopped, or in a pause, fast-forward or chapter-search mode, the digital audio data will momentarily stop, the channel position letters inside the **Speaker/Channel Input Indicators 25** will flash. This is normal and does not indicate a problem with either the AVR 340 or the source machine. The AVR 340 will return to digital playback as soon as the data is available and when the machine is in a standard play mode.
- When playing DVDs or viewing television signals with digital audio, the number of channels and format of the incoming bitstream may vary depending on the portion of the DVD being viewed (e.g. trailers, director's commentary), or when commercials or local station identification is broadcast. The AVR 340 will automatically react to changes in the incoming signal.

- Some television system broadcasters are not capable of transmitting a 5.1 digital signal. Therefore, although the program material may be encoded in the Dolby Digital or DTS formats, the actual broadcast may only be a 2.0 signal. Check with your cable or satellite provider for more information.
- Although the AVR 340 will decode virtually all current DVD movies, CDs and HDTV sources, it is possible that some future digital sources may not be compatible with the AVR 340.
- Not all digitally encoded programs contain full 5.1- or 6.1-channel audio. Consult the program guide that accompanies the DVD or laser disc to determine which type of audio has been recorded on the disc. The AVR 340 will automatically sense the type of digital surround encoding used and adjust to accommodate it.
- When some digital sources are playing, you may not be able to select some of the analog surround modes such as Dolby Pro Logic II or IIx, Dolby 3 Stereo, Hall, Theater or Logic 7. Refer to the tables on page 40 for more information.
- When a Dolby Digital or DTS source is playing, it is not possible to make an analog recording using the **Tape Outputs 43** and **Video 1 Audio Outputs 38**. However, the digital signals will be passed through to the **Digital Audio Outputs 23/24**.

Tuner Operation

The AVR 340's tuner is capable of tuning AM, FM and FM Stereo broadcast stations. Stations may be tuned manually, or they may be stored as favorite station presets and recalled from a 30-position memory.

Station Selection

1. Press the **AM/FM Tuner Select Button 7 C** on the remote to select the tuner as an input. The tuner may be selected from the front panel either by pressing the **Input Source Selector 16** until the tuner is active or by pressing the **Tuner Band Selector 11**.
2. Press the **AM/FM Tuner Select Button 7 C** or **Tuner Band Selector 11** again to switch between AM and FM so that the desired frequency band is selected.
3. Press the **Tuner Mode Button 17/19** to select manual or automatic tuning.

When the button is pressed so that **AUTO** appears in the **Lower Display Line 27** each press of the **Tuning Selectors 9/21** will put the tuner in a scan mode that seeks the next higher- or lower-frequency station with acceptable signal strength. An **AUTO ST TUNED** indication will momentarily appear when the station stops at a stereo FM station, and an **AUTO TUNED**

indication will momentarily appear when an AM or monaural FM station is tuned. Press the Tuning buttons again to scan to the next receivable station.

When the button is pressed so that **MANUAL** appears in the **Lower Display Line 27** each tap of the Selector will increase or decrease the frequency by one increment. When the tuner receives a strong-enough signal for adequate reception, **MANUAL TUNED** will appear in the **Lower Display Line 27**.

4. Stations may also be tuned directly in either the automatic or manual mode. To enter a station's frequency directly, first select the AM or FM band as desired by pressing the **AM/FM Tuner Select Button 7**. Next, press the **Direct Button 20**. Within five seconds of seeing the **DIRECT IN** scroll in the **Upper Display Line 26**, enter the station frequency by pressing the **Numeric Keys 18**. If you press an incorrect button while entering a direct frequency, press the **Clear Button 33** to start over.

NOTE: When FM reception of a station is weak, audio quality will be increased by switching to Mono mode by pressing the **Tuner Mode Button 17/19** so that **MANUAL** appears momentarily in the **Lower Display Line 27** and goes out. This will also activate manual tuning mode.

Preset Tuning

Using the remote, up to 30 stations may be stored in the AVR 340's memory for easy recall using the front panel controls or the remote.

To enter a station into the memory, first tune the station using the steps outlined above. Then:

1. Press the **Memory Button 34** on the remote. Two underscore lines will appear at the far right side of the **Upper Display Line 26**.
2. Within 5 seconds, press the **Numeric Keys 18** corresponding to the location where you wish to store this station's frequency. Once entered, the preset number will appear in the **Upper Display Line 26**.
3. Repeat the process after tuning any additional stations to be preset.

Recalling Preset Stations

- To manually select a station previously entered in the preset memory, press the **Numeric Keys 18** that correspond to the desired station's memory location.
- To manually tune through the list of stored preset stations one by one, press the **Preset Stations Selector Buttons 14/30 E** on the front panel or remote.

OPERATION

Recording

In normal operation, the audio or video source selected for listening through the AVR 340 is sent to the record outputs. This means that any program you are watching or listening to may be recorded simply by placing machines connected to the **Tape Outputs 43** or **Video 1 or 2 Audio/Video and S-Video Outputs 30, 32, 33, 40** in the Record mode.

When a digital audio recorder is connected to the **Digital Audio Outputs 23, 24**, you are able to record the digital signal using a CD-R, MiniDisc or other digital recording system.

NOTES:

- The digital outputs are active only when a digital signal is present, and they do not convert an analog input to a digital signal, or change the format of the digital signal. In addition, the digital recorder must be compatible with the output signal. For example, the PCM digital input from a CD player may be recorded on a CD-R or MiniDisc, but Dolby Digital or DTS signals may not.
- Please make certain that you are aware of any copyright restrictions on any material you copy. Unauthorized duplication of copyrighted materials is prohibited by federal law.

Using The Bridge

When Harman Kardon's **The Bridge** (optional) is connected and a compatible iPod is docked in The Bridge, press the **DMP The Bridge Selector Button 40** to choose the iPod as the input source. Pressing the **DMP The Bridge Selector Button 40** will also activate the AVR remote's control codes for the iPod, and you may also use the front-panel controls to operate the iPod. You may also select **DMP The Bridge** as the source from the front panel by repeatedly pressing the **Input Source Selector 16** until **DMP** appears in the **Upper Display Line 26**, although no **Input Indicator 24** will light.

When The Bridge is properly connected and a compatible iPod is properly docked, **DMP/THE BRIDGE IS CONNECTED** will scroll across the **Upper Display Line 26**. Once that message appears, use the remote or front-panel buttons to control the iPod. See the Function List Table on pages 51–52 for a listing of the remote control buttons that have been programmed to control the iPod. In brief, the **Reverse Search, Play, Pause and Forward Search Buttons 27, E, H, I, J** and the **▲/▼/◀/▶ Buttons 14, 15, F** and **Set Button 16, 1** may be used in a similar manner to the corresponding controls on the iPod. Complete details on operating an iPod using **The Bridge** and an AVR remote are furnished with **The Bridge**.

The front-panel controls may be used to access a number of iPod functions. Press the **Tuner Mode Button 17** to play or pause the current track. The **Tuning Selector 9** may be used to search reverse (left side of button) or forward (right side of button) through the tracks. Press the **Tuner Band Selector 11** to call up the iPod's menu. Press the **Preset Station Selectors 14** to scroll, and the **Set Button 12** to select. For complete information on using the AVR's remote or front-panel controls to operate an iPod, see the instructions packed with The Bridge.

Output Level Trim Adjustment

Normal output level adjustment for the AVR 340 is established using EzSet/EQ, or the internal test tone, as outlined on pages 31–32. In some cases, however, it may be desirable to adjust the output levels using program material such as a test disc, or a selection you are familiar with.

To adjust the output levels using program material, first set the reference volume for the front left and front right channels using the **Volume Control 23, 38**.

If you are using a disc with test signals or an external signal generator as the source from which to trim the output levels, you may use a handheld SPL meter to guide you to the correct SPL levels. Set the meter to the C-Weighting Slow scale, and adjust the volume until the meter reads 75dB.

Once the reference level has been set, press the **Channel Select Button 13** and **FRONT LEVEL** will appear in the **Lower Display Line 27** and semi-OSD. To change the level, first press the **Set Button 16**, and then use the **▲/▼ Buttons 14** to raise or lower the level. DO NOT use the volume control, as this will alter the reference setting.

Once the change has been made, press the **Set Button 16** and then press the **▲/▼ Buttons 14** to select the next output channel location you wish to adjust. To adjust the subwoofer level, press the **▲/▼ Buttons 14** until **WOOFER LEVEL** appears in the **Lower Display Line 27** and on screen.

Repeat the procedure as needed until all channels requiring adjustment have been set. When all adjustments have been made and no further adjustments are made for five seconds, the AVR 340 will return to normal operation.

The channel output for any input may also be adjusted using the full-OSD on-screen menu system. First, set the volume to a comfortable listening level using the **Volume Control 23, 38**. Then, press the **OSD Button 22** to bring up the **MASTER MENU** (Figure 1). Press the **▼ Button 14** until the on-screen **▶** cursor is next to **MANUAL SETUP**.

Then press the **Set Button 16** to display the **MANUAL SETUP** submenu, and use the **▲/▼ Buttons 14** to scroll to the **CHANNEL ADJUST** line. Press the **Set Button 16** again to display the **CHANNEL ADJUST** submenu.

Once the menu appears on your video screen, first use the **▲/▼ Buttons 14** to move the on-screen **▶** cursor so that it is next to the **TEST TONE** line. Press the **◀/▶ Buttons 15** so that **OFF** appears. This will turn off the test tone and allow you to use your external test disc or other source material as the reference. Then, use the **▲/▼ Buttons 14** until the **▶** cursor is next to the **TEST TONE SEQ** line so that you may select between automatic and manual movement of the test tone from one channel to the next. When **AUTO** appears, the test tone will automatically circulate from one channel to the next, pausing momentarily at each channel. If you adjust the level of any channel, the test tone will remain paused at that channel until several seconds after your last adjustment before continuing to the next channel. When **MANUAL** appears, the test tone will remain paused at the last channel until you use the **▲/▼ Buttons 14** to select another channel.

At each channel position, use the **◀/▶ Buttons 15** to change the output level. Remember, the goal is to have the output level at each channel be equal when heard at the listening position.

If you wish to reset all the levels to their original factory default of 0dB offset, press the **▲/▼ Buttons 14** so that the on-screen cursor is next to the **CHANNEL RESET** line and press the **◀/▶ Buttons 15** so that the word **ON** appears. After the levels are reset, resume the procedure outlined above to reset the levels to the desired settings. When all adjustments are done, press the **▲/▼ Buttons 14** to move the on-screen **▶** cursor so that it is next to **BACK TO MANUAL SETUP** and then press the **Set Button 16** if you wish to go back to the manual setup menu to make other adjustments. If you have no other adjustments to make, press the **OSD Button 22** to exit the menu system.

NOTE: The output levels may be separately trimmed for each digital and analog surround mode by selecting that mode and following the instructions shown above.

Dim Function

Since the AVR 340 will often be used when movies or other video programming is viewed under low-light conditions, you may wish to lower the brightness of the front-panel displays and indicators so that they do not distract from the video presentation. You may dim the displays using the remote.

Simply press the **Dim Button 8** once to dim the front panel to half the normal brightness level; press it again to turn the displays off. Note that when the displays are dimmed or turned off, the blue **Power Indicator 2** will remain lit as a reminder that the AVR is still turned on. The accent lighting for the **Volume Control 23** will dim when the panel displays are at half brightness.



Note that all changes to the front-panel brightness level are temporary; the displays will return to full brightness after the AVR is turned off and then on again. To return the displays to full brightness without turning the unit off, press the **Dim Button 8** as needed until the displays are on.

In addition to lowering the brightness of the displays or turning them off completely, you may wish to have them appear whenever a button on the remote or front panel is pushed, and then gradually fade out after a set time period. You may do this by making the appropriate settings in the **VFD FADE TIME OUT** line of the **ADVANCED SELECT** Menu, as shown on page 44.

Memory Backup

This product is equipped with a memory backup system that preserves the system configuration information and tuner presets if the unit is accidentally unplugged or subjected to a power outage. This memory will last for approximately four weeks, after which time all information must be reentered.

TROUBLESHOOTING GUIDE

SYMPTOM	CAUSE	SOLUTION
Unit does not function when Main Power Switch is pushed	<ul style="list-style-type: none"> No AC Power 	<ul style="list-style-type: none"> Make certain AC power cord is plugged into a live outlet Check to see whether outlet is switch-controlled
Display lights, but no sound or picture	<ul style="list-style-type: none"> Intermittent input connections Mute is on Volume control is down 	<ul style="list-style-type: none"> Make certain that all input and speaker connections are secure Press Mute Button   Turn up volume control
No sound from any speaker; light around power switch is red	<ul style="list-style-type: none"> Amplifier is in protection mode due to possible short Amplifier is in protection mode due to internal problems 	<ul style="list-style-type: none"> Check speaker wire connections for shorts at receiver and speaker ends Contact your local Harman Kardon service center
No sound from surround or center speakers	<ul style="list-style-type: none"> Incorrect surround mode Input is monaural Incorrect configuration Stereo or Mono program material 	<ul style="list-style-type: none"> Select a mode other than Stereo There is no surround information from mono sources Check speaker mode configuration The surround decoder may not create center- or rear-channel information from nonencoded programs
Unit does not respond to remote commands	<ul style="list-style-type: none"> Weak batteries in remote Wrong device selected Remote sensor is obscured 	<ul style="list-style-type: none"> Change remote batteries Press the AVR selector Make certain front panel sensor is visible to remote or connect remote sensor
Intermittent buzzing in tuner	<ul style="list-style-type: none"> Local interference 	<ul style="list-style-type: none"> Move unit or antenna away from computers, fluorescent lights, motors or other electrical appliances
Letters flash in the channel indicator display and digital audio stops	<ul style="list-style-type: none"> Digital audio feed paused 	<ul style="list-style-type: none"> Resume play for DVD Check that Digital Input is selected

In addition to the items shown above, additional information on troubleshooting possible problems with your AVR 340, or installation-related issues, may be found in the list of "Frequently Asked Questions" which is located in the Product Support section of our Web site at www.harmankardon.com.

Processor Reset

In the rare case in which the unit's operation or the displays seem abnormal, the cause may involve the erratic operation of the system's memory or microprocessor.

To correct this problem, first unplug the unit from the AC wall outlet and wait at least three minutes. After the pause, reconnect the AC power cord and check the unit's operation. If the system still malfunctions, a system reset may clear the problem.

To clear the AVR 340's entire system memory including tuner presets, output level settings, delay times and speaker configuration data, first place the AVR in Standby Mode, and then press and hold the **Tone Mode Button**  button for three seconds. The unit will turn on automatically.

NOTE: Resetting the processor will erase any configuration settings you have made for speakers, output levels, surround modes, digital input assignments as well as the tuner presets. Before performing a processor reset, we suggest that you record your current system settings on the worksheet found on page XX. The unit will be returned to the factory presets, and all settings for these items must be reentered.

If the system is still operating incorrectly, there may have been an electronic discharge or severe AC line interference that has corrupted the memory or microprocessor.

If these steps do not solve the problem, consult an authorized Harman Kardon service center.

Service bulletin # HK2006-01 January 2006

Warranty labor rate: MINOR repair

To: All harman/kardon Service Centers

Models: AVR135, AVR140, AVR240, AVR340,
AVR135/230v, AVR235/230v, AVR335/230v, AVR140/230v, AVR240/230v, AVR340/230v

Subject: Defective Wafer

In the event you receive an AVR135, AVR140, AVR240, AVR340, AVR135/230v, AVR235/230v, AVR335/230v, AVR140/230v, AVR240/230v, or AVR340/230v receiver with the complaint “there is no On Screen Display (OSD) output through the Composite, S-video, or Component Video* connections, or no video pass-through from S-Video or Composite connections”, perform the following procedure:

Synopsis: Flat flex cable assembly possibly not making a good contact with defective wafer connector CN72, located on the Input PCB.

Check to see if the affected unit falls into the serial number range(s) below, which may need modification.

- 1) Remove the top cover
- 2) Remove the Tuner PCB and Video PCB's.
- 3) Remove the Input PCB; replace 16 pin wafer connector CN72 with h/k part# KJP32GA117ZG.
- 4) Replace all PCB's in reverse order, and the top cover.
- 5) Test the unit.

MODEL	SERIAL NUMBER (120V)	SERIAL NUMBER (230V)	STATUS	ACTION
AVR135	AN0020-28676 to AN0020-33475		May Need Modification	Replace Wafer
AVR140	AN0031-04201 to AN0031-16800		May Need Modification	Replace Wafer
AVR240	AN0032-01001 to AN0032-13000		May Need Modification	Replace Wafer
AVR340	AN0033-01001 to AN0033-09000		May Need Modification	Replace Wafer
AVR135 in CP15 system	AN0023-08026 to AN0023-09825		May Need Modification	Replace Wafer
AVR235 in CP25 system	AN0024-03001 to AN0024-04000		May Need Modification	Replace Wafer
AVR335 in CP35 system	AN0025-04101 to AN0025-05100		May Need Modification	Replace Wafer
AVR135/230		AN0027-14356 to AN0027-17965	May Need Modification	Replace Wafer
AVR235/230		AN0028-11601 to AN0028-20300	May Need Modification	Replace Wafer
AVR335/230		AN0029-07401 to AN0029-09830	May Need Modification	Replace Wafer
AVR140/230		AN0034-01001 to AN0034-04600	May Need Modification	Replace Wafer
AVR240/230		AN0035-01001 to AN0035-03400	May Need Modification	Replace Wafer
AVR340/230		AN0036-01001 to AN0036-02200	May Need Modification	Replace Wafer

* Note: For the models above, excluding the AVR340, the full On Screen Display (OSD) normally will not be visible with Component video connections alone. For model AVR340, when the component video jacks are used, the onscreen menus are not visible with high-definition video (720p or 1080i), and you must switch to the standard composite or S-video input on your TV, or to a 480p video source, to view them.

harman/kardon**TECH TIPS****Troubleshooting tips and solutions to common service problems**

For models:

TIP# HKTT2003-01 Rev7

AVR7000/7200/7300/8000

AVR10

AVR100/200/300/500

DPR1001

AVR110/210/310/510

DPR1005

AVR120/220/320/520

DPR2005

AVR125/225/325/525

HK3370/3470/3375/3475

AVR130/230/330/430/630

HK3250

AVR135/235/335/435/635

AVR140/240/340

Subject: Backup Memory on AVR/DPR/HK series receivers**In the event of the complaint: “the receiver is losing its memory (any programmed system settings) when the unit is turned off, or after the unit is unplugged (briefly*)”:**

Check and replace:

Model	Designator	Location	Description	Part number
AVR10	C712 D709	Front PCB	0.047 Farad 5.5v capacitor and 1N4148 diode	#3439247315 #2058322101
AVR7000	C730	Front PCB	0.047 Farad 5.5v capacitor	# P10790-ND or # J3432147324X
AVR7200	C106	Front PCB	0.047 Farad 5.5v capacitor	# P10790-ND
AVR7300	C657	DSP PCB	0.047 Farad 5.5v capacitor	# H01-CEZXA0479MN-5
AVR8000	C726	Front PCB	0.047 Farad 5.5v capacitor	# 55230310NR or # P10790-ND
AVR100/200	C412	Front PCB	0.047 Farad 5.5v capacitor	# CEGT-B473J-0J0
AVR300	C906	Front PCB	0.1Farad 5.5v capacitor	# J4433210421X or # P10791-ND
AVR500	C906	Front PCB	0.1Farad 5.5v capacitor	# J4433210421X or # P10791-ND
AVR110/210/310/510 AVR120/220/320/520	C216	Front PCB	0.047 Farad 5.5v capacitor	# P10790-ND
AVR125/225	C734,C885	Front PCB	two 0.1F capacitors in parallel	# BCESOHD104
AVR325/525	C106	Front PCB	0.047 Farad 5.5v capacitor	# P10790-ND
AVR130/230/330	BAT1	Front PCB	3.6v Battery	# HABGP40BVH3A3H
AVR135/235/335	BAT1	Front PCB	3.6v Battery	# HGP15BNH3A3H
AVR140/240/340	BAT1	Front PCB	3.6v Battery	# HABGP40BVH3A3H
AVR430/630	C657	DSP PCB	0.047 Farad 5.5v capacitor	# CEZXA0479MN-5
AVR435/635	C557	DSP PCB	0.047 Farad 5.5v capacitor	# H03-CEZXA0479MN-0
DPR1001	BC601	Main PCB	0.1Farad 5.5v capacitor	# CEGT-B104J-0J0
DPR1005/2005	C437	Processor PCB	0.047 Farad 5.5v capacitor	# CEZXA0479MN-5
HK3370/3470	C301	Front PCB	0.1Farad 5.5v capacitor	# CEGT-B104J-0J0
HK3375/3475	C301	Front PCB	0.1Farad 5.5v capacitor	# CEGT-B104J-0J0
HK3250	C712 D709	Front PCB	0.047 Farad 5.5v capacitor and 1N4148 diode	#3439247315 #2058322101

* After approximately two weeks of being disconnected from AC supply, even a normally functioning receiver may lose any programmed settings and switch to default settings. (Four weeks for the DPR1005 & 2005)

1. Removing the Top Cabinet
Remove the Screws

①~⑬

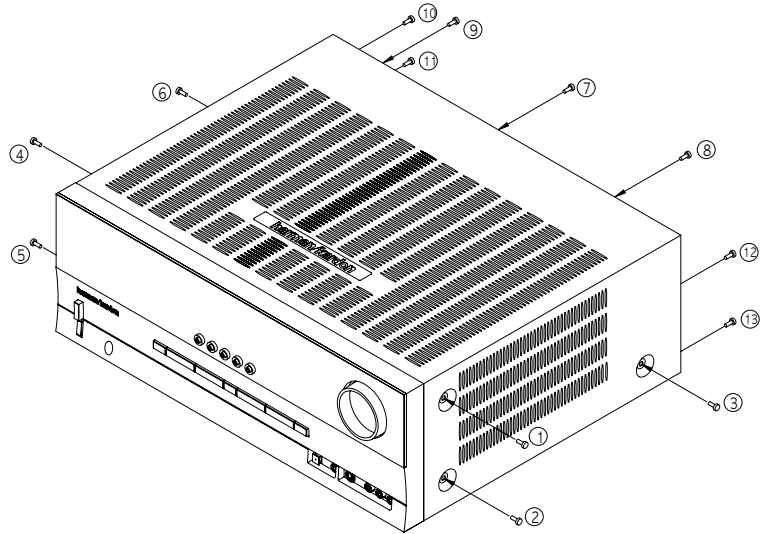

2. Removing the Front Panel
Remove the Screws

①~⑨

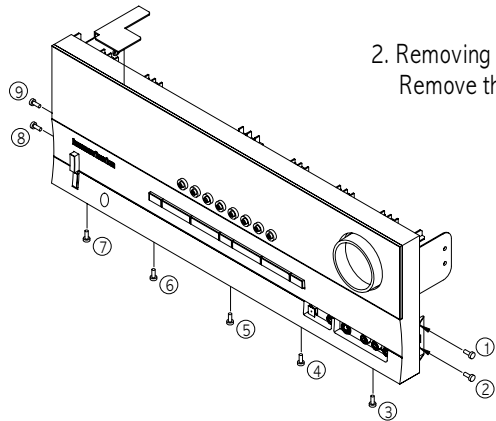

3. Removing the Rear Panel
Remove the Screws

①~④③

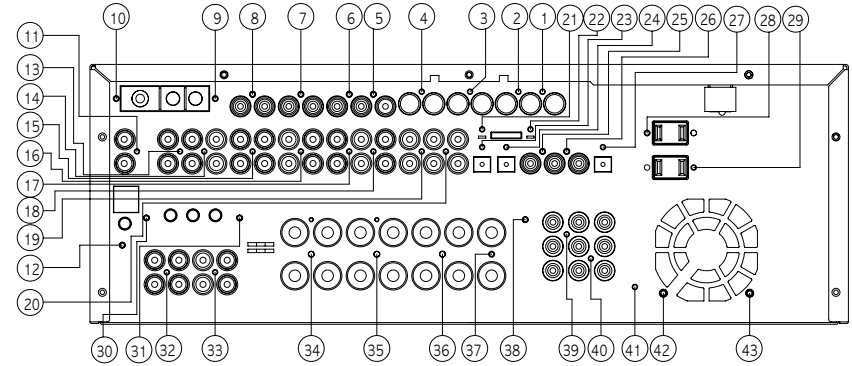

4. Removing the Main PCB
Remove the Screws

①~⑧

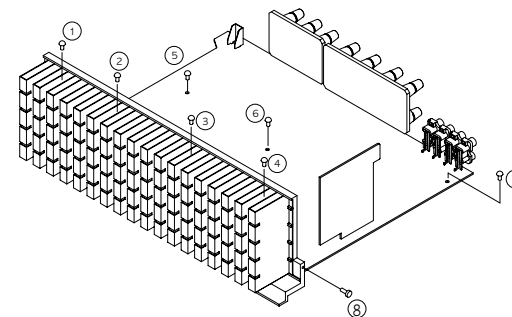

DISASSEMBLY PROCEDURES(AVR340)

<1> TOP-CABINET(21) REMOVAL

1. Remove 13 screws(S1,S7) and then remove the Top-cabinet.

<2> FRONT PANEL ASS'Y REMOVAL

1. Remove the Top-cabinet, referring to the previous step<1>.
2. Disconnect the lead wire (BN72-32p) on the Fip PCB(37-1) from connector(CN72) on the Input PCB(39-1)
3. Disconnect the lead wire(BN80-11P) on the Fip PCB(37-1) from connector(CN80) on the Main PCB(38-1).
4. Disconnect the lead wire(BN16-6P) on the Tone PCB(37-3) from connector(CN16) on the Connect PCB(37-7).
5. Disconnect the lead wire(BN41-6P) on the Tone PCB(37-3) from connector(CN41) on the Video PCB(40-1).
6. Disconnect the lead wire(BN18-5P) on the Digital input PCB(37-8) from connector(CN18) on the Input PCB(39-1).
7. Disconnect the lead wire(BN81-8P) on the Fip PCB(37-1) from connector(CN81) on the Trans PCB(40-5).
8. Disconnect the lead wire(BN15-8P) on the Fip PCB(37-1) from connector(CN15) on the Download PCB(37-9).
9. Remove 1 screw(S10) and then lead wire(JW82-2P) on the Phone PCB(37-4).
10. Remove 1 screw(S10) and then lead wire(JW84-1P) on the Tone PCB(37-3)
10. Remove 10 screws(S1) and then remove the Front Panel ASS'Y.

<3> TONE PCB(37-3) REMOVAL

1. Remove the Top-cabinet, referring to the previous step<1>.
2. Remove the Front Panel ASS'Y, referring to the previous step<2>.
3. Pull out the Volume Knob ASS'Y & 3 Rotary Knobs(5).
4. Remove 10 screws(S2,S14), and then remove the Tone PCB(37-3).
5. Disconnect the lead wire(BN84-5P) One the Tone PCB(37-3) from connector(CN84) on the Fip PCB(37-1)

<4>PHONE PCB(37-4) REMOVAL

1. Remove the Top-cabinet, referring to the previous step<1>.
2. Remove the Front Panel ASS'Y, referring to the previous step<2>.
3. Disconnect the lead wire (BN85-2P) on the Fip PCB(37-1) from connector(CN85) on the Phone PCB(37-4)
4. Remove 2 screws(S2,S3) and then remove the Phone PCB(37-4)

<5>POWER LED PCB(37-6) REMOVAL

1. Remove the Top-cabinet, referring to the previous step<1>.
2. Remove the Front Panel ASS'Y, referring to the previous step<2>.
3. Remove 2 screws(S2) and then remove the Power led PCB(37-6).
4. Disconnect the lead wire(CN88) from connector(BN88-4P) on the Fip PCB(37-1).

<6>FIP PCB(37-1) REMOVAL

1. Remove the Top-cabinet, referring to the previous step<1>.
2. Remove the Front Panel ASS'Y, referring to the previous step<2>.
3. Remove the Tone PCB(37-3), referring to the previous step<3>.
4. Remove the Phone PCB(37-4), referring to the previous step<4>.
5. Remove the Power led PCB(37-6), referring to the previous step<5>.
6. Remove 6 screws(S2) and then remove the Fip PCB(37-1)

<7>TUNER MODULE(42) REMOVAL

1. Remove the Top-cabinet, referring to the previous step<1>.
2. Disconnect the connector(CON1-Card cable) from connector(CN13) on the Input PCB ASS'Y(39-1).
3. Remove 2 screws(S8) and then remove the Tuner Module(42).

<8>VIDEO PCB(40-1) REMOVAL

1. Remove the Top-cabinet, referring to the previous step<1>.
2. Disconnect the lead wire(BN41-6P) on the Tone PCB(37-3) from connector(CN41) on the Video PCB(40-1)
3. Disconnect the connector (CN15-Card cable) on the Input PCB(39-1) from connector(CN43) on the Video PCB(40-1).
4. Remove 6 screws(S8) and then remove the Video PCB(40-1).

<9>I-POD PCB(41) REMOVAL

1. Remove the Top-cabinet, referring to the previous step<1>.
2. Disconnect the lead wire(BN42-5P) on the INPUT PCB(39-1) from connector(CN42) on the I-POD PCB(41).
3. Disconnect the lead wire(BN45-4P) on the INPUT PCB(39-1) from connector(CN45) on the I-POD PCB(41).
4. Disconnect the lead wire(BN44-4P) on the Download PCB(37-9) from connector(CN42) on the I-POD PCB(41).
5. Remove 2 screws(S13) and then remove the I-POD PCB(41).

<10>INPUT PCB(39-1) REMOVAL

1. Remove the Top-cabinet, referring to the previous step<1>.
2. Remove the Connect PCB(37-7).
3. Disconnect the lead wire(BN18-5P) on the Digital input PCB(37-8) from connector(CN18) on the Input PCB(39-1).
4. Disconnect the connect (BN72-Card canle) on the Fip PCB(37-1) from connector(CN72) on the Input PCB(39-1)
5. Remove 11 screws(S8,S11) and then remove the Input PCB(39-1).

<11>Download PCB(37-9) REMOVAL

1. Remove the Top-cabinet, referring to the previous step<1>.
2. Disconnect the connector(CN15) from lead wire(BN15-8P) on the Fip PCB(37-2)
3. Remove 2 screws(S4) and then remove the Download PCB(37-9).

<12>POWER TRANS(36) REMOVAL

1. Remove the Top-cabinet, referring to the previous step<1>.
2. Disconnect the connector (BN20,BN96) on the Trans PCB(40-4) from lead wire(CN20-3P,CN96-6P) on the Main PCB(38-1).
3. Remove 4 Trans screws(S9) and then remove the Power Trans(36).

<13>MAIN PCB ASS'Y(38-1) REMOVAL

1. Remove the Top-cabinet, referring to the previous step<1>.
2. Remove the Tuner module, referring to the previous step<7>.
3. Remove the Video PCB, referring to the previous step<8>.
4. Remove the Input PCB, referring to the previous step<9>.
5. Disconnect the connector(CN80) from lead wire(BN80-11P) on the Fip PCB(37-1).
6. Disconnect the connector(CN91) from lead wire(BN91-3P) on the Moms PCB(37-5).
7. Disconnect the connector (CN20,BN96) from lead wire(CN20-3P,BN96-8P) on the Trans PCB(40-4,40-5)
8. Remove 11 screws(S1-1EA, S4-2EA, S6-2EA, S8-6EA) and then remove the Main PCB ASS'Y(38-1).

AVR340 EXPLODED VIEW

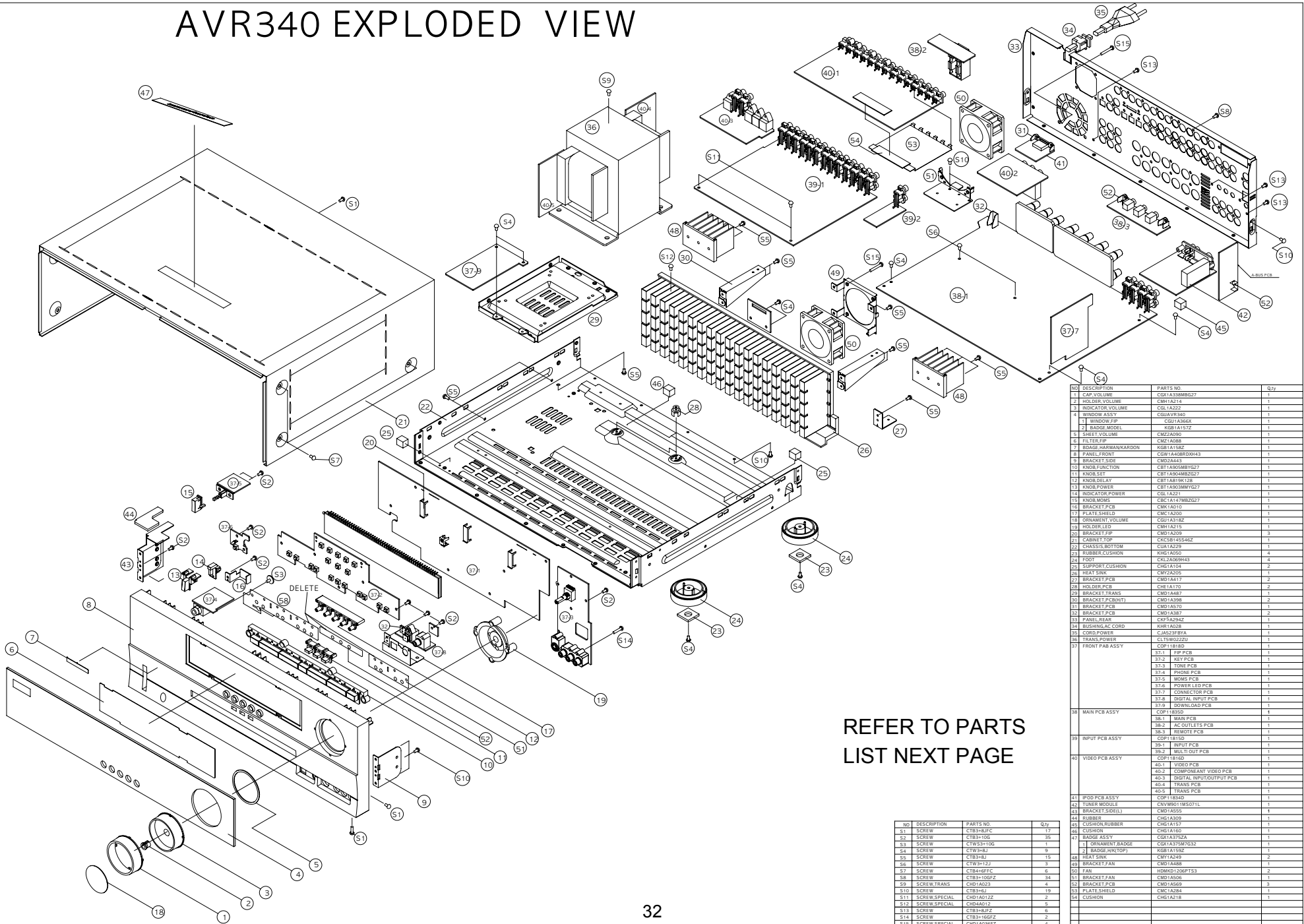

REFER TO PARTS LIST NEXT PAGE

NO	DESCRIPTION	PARTS NO	Qty
S1	SCREW	CTB3H2FC	13
S2	SCREW	CTB3H10G	35
S3	SCREW	CTB3H10G	1
S4	SCREW	CTB3H3J	9
S5	SCREW	CTB3H4J	15
S6	SCREW	CTB3H2LJ	3
S7	SCREW	CTB4H6FFC	6
S8	SCREW	CTB3H10GFZ	34
S9	SCREW TRANS	CHD1A023	4
S10	SCREW	CTB3H4J	19
S11	SCREW SPECIAL	CHD1A013Z	2
S12	SCREW SPECIAL	CHD1A012	6
S13	SCREW	CTB3H2GFZ	6
S14	SCREW	CTB3H16GFZ	2
S15	SCREW SPECIAL	CHD1A036FZ	4

NO	DESCRIPTION	PARTS NO	Qty
1	CAP VOLUME	CG1A338B027	1
2	HOLDER VOLUME	CMH1A214	1
3	INDICATOR VOLUME	CG1A323	1
4	WINDOW ASSY	CG1AVR340	1
1	1 WINDOW PFC	CG1A350X	1
2	2 BADGE MODEL	KG1A157Z	1
5	SHEET VOLUME	CMZ2A090	1
6	FILTER PFC	CM1A088	1
7	SDAGE HARMANKARDON	KG1A158Z	1
8	PANEL FRONT	CGW1A08B00H43	1
9	BRACKET SIDE	CM1A056	1
10	KNOB FUNCTION	CBT1A020MBYG27	1
11	KNOB SET	CBT1A020MBYG27	1
12	KNOB DISPLAY	CBT1A020MBYG27	1
13	KNOB POWER	CBT1A020MBYG27	1
14	INDICATOR POWER	CG1A325	1
15	KNOB MODE	CBT1A147MBYG27	1
16	BRACKET PCB	CMK1A010	1
17	PLATE SHIELD	CMK1A200	1
18	ORNAMENT VOLUME	CG1A318Z	1
19	HOLDER LED	CMK1A215	1
20	BRACKET P/F	CM1A209	3
21	CABINET TOP	CKC1B145546Z	1
22	CHASSIS BOT/TOP	CG1A325	1
23	RUBBER CUSHION	KG1A050	4
24	FOOT	CMZ2A09H43	4
25	SUPPORT CUSHION	KG1A104	2
26	HEAT SINK	CMY2A205	1
27	BRACKET PCB	CM1A057	2
28	HOLDER PCB	CH1A170	2
29	BRACKET TRANS	CM1A487	1
30	BRACKET PCB(R/W)	CM1A306	2
31	BRACKET PCB	CM1A570	1
32	BRACKET PCB	CM1A387	2
33	PANEL REAR	CKE2A024Z	1
34	BUSHING LAC CORD	KHR1A028	1
35	CORD POWER	CAJ23P8YA	1
36	TRANS POWER	CL1W32220	1
37	FRONT PAB ASSY	COP118340	1
		37.1 SW PCB	1
		37.2 KEY PCB	1
		37.3 TONE PCB	1
		37.4 PHONO PCB	1
		37.5 MDMS PCB	1
		37.6 POWER LED PCB	1
		37.7 CONNECTOR PCB	1
		37.8 DIGITAL INPUT PCB	1
		37.9 DOWN/UP PCB	1
38	MAIN PCB ASSY	COP118340	1
		38.1 MAIN PCB	1
		38.2 AC OUTLETS PCB	1
		38.3 REMOTE PCB	1
39	INPUT PCB ASSY	COP118340	1
		39.1 INPUT PCB	1
		39.2 MULTI OUT PCB	1
40	VIDEO PCB ASSY	COP118340	1
		40.1 VIDEO PCB	1
		40.2 COMPONENT VIDEO PCB	1
		40.3 DIGITAL INPUT OUTPUT PCB	1
		40.4 TRANS PCB	1
		40.5 TRANS PCB	1
41	IPOD PCB ASSY	COP118340	1
		41.1 IPOD PCB	1
42	TUNER MODULE	CNV95011MS071L	1
43	BRACKET SIDE(R/L)	CM1A056	1
44	RUBBER	CH1A309	1
45	CUSHION RUBBER	CH1A157	1
46	CUSHION	CH1A150	1
47	BADGE ASSY	CG1A325ZA	1
1	1 BRACKET SIDE	CG1A325YG27	1
2	2 BADGE (R/TOP)	KG1A150Z	1
48	HEAT SINK	CMY1A249	2
49	BRACKET FAN	CM1A488	1
50	FAN	HM1M120P153	2
51	BRACKET FAN	CM1A556	1
52	BRACKET PCB	CM1A569	3
53	PLATE SHIELD	CMC1A284	1
54	CUSHION	CH1A218	1

NO	DESCRIPTION	PARTS NO.	Qty
1	CAP,VOLUME	CGX1A338MBG27	1
2	HOLDER,VOLUME	CMH1A214	1
3	INDICATOR,VOLUME	CGL1A222	1
4	WINDOW ASS'Y	CGUAVR340	1
	1 WINDOW,FIP	CGU1A366X	1
	2 BADGE,MODEL	KGB1A157Z	1
5	SHEET,VOLUME	CMZ2A090	1
6	FILTER,FIP	CMZ1A088	1
7	BADGE ,HARMAN/KARDON	KGB1A158Z	1
8	PANEL,FRONT	CGW1A408RDXH43	1
9	BRACKET,SIDE	CMD2A443	1
10	KNOB,FUNCTION	CBT1A905MBYG27	1
11	KNOB,SET	CBT1A904MBZG27	1
12	KNOB,DELAY	CBT1A819K128	1
13	KNOB,POWER	CBT1A903MMYG27	1
14	INDICATOR,POWER	CGL1A221	1
15	KNOB,MOMS	CBC1A147MBZG27	1
16	BRACKET,PCB	CMK1A010	1
17	PLATE,SHIELD	CMC1A200	1
18	ORNAMENT,VOLUME	CGU1A318Z	1
19	HOLDER,LED	CMH1A215	1
20	BRACKET,FIP	CMD1A209	3
21	CABINET,TOP	CKC5B145S46Z	1
22	CHASSIS,BOTTOM	CUA1A229	1
23	RUBBER,CUSHION	KHG1A050	4
24	FOOT	CKL2A069H43	4
25	SUPPORT,CUSHION	CHG1A104	2
26	HEAT SINK	CMY2A205	1
27	BRACKET,PCB	CMD1A417	2
28	HOLDER,PCB	CHE1A170	2
29	BRACKET,TRANS	CMD1A487	1
30	BRACKET,PCB(H/T)	CMD1A398	2
31	BRACKET,PCB	CMD1A570	1
32	BRACKET,PCB	CMD1A387	2
33	PANEL,REAR	CKF5A294Z	1
34	BUSHING,AC CORD	KHR1A028	1
35	CORD,POWER	CJA523FBYA	1
36	TRANS,POWER	CLT5W022ZU	1
37	FRONT PCB ASS'Y		1
		37-1 FIP PCB	1
		37-2 KEY PCB	1
		37-3 TONE PCB	1
		37-4 PHONE PCB	1
		37-5 MOMS PCB	1
		37-6 POWER LED PCB	1
		37-7 CONNECTOR PCB	1
		37-8 DIGITAL INPUT PCB	1
		37-9 DOWNLOAD PCB	1
38	MAIN PCB ASS'Y		1
		38-1 MAIN PCB	1
		38-2 AC OUTLETS PCB	1
		38-3 REMOTE PCB	1
39	INPUT PCB ASS'Y		1
		39-1 INPUT PCB	1
		39-2 MULTI OUT PCB	1
40	VIDEO PCB ASS'Y		1
		40-1 VIDEO PCB	1
		40-2 COMPONEANT VIDEO PCB	1
		40-3 DIGITAL INPUT/OUTPUT PCB	1
		40-4 TRANS PCB	1
		40-5 TRANS PCB	1
41	IPOD PCB ASS'Y		1
42	TUNER MODULE	CNVM9011MS071L	1
43	BRACKET,SIDE(L)	CMD1A555	1
44	RUBBER	CHG1A309	1
45	CUSHION,RUBBER	CHG1A157	1
46	CUSHION	CHG1A160	1
47	BADGE ASS'Y	CGX1A375ZA	1
	1 ORNAMENT,BADGE	CGX1A375M7G32	1
	2 BADGE,H/K(TOP)	KGB1A159Z	1
48	HEAT SINK	CMY1A249	2
49	BRACKET,FAN	CMD1A488	1
50	FAN	HDMKD1206PTS3	2
51	BRACKET,FAN	CMD1A506	1
52	BRACKET,PCB	CMD1A569	3
53	PLATE,SHIELD	CMC1A284	1
54	CUSHION	CHG1A218	1

AMPLIFIER SECTION BIAS ADJUSTMENT

Measurement condition

. No input signal or volume position is minimum.

Standard value.

. Ideal current = 48mA (± 5%)

. Ideal DC Voltage = 25.92mV (± 5%)

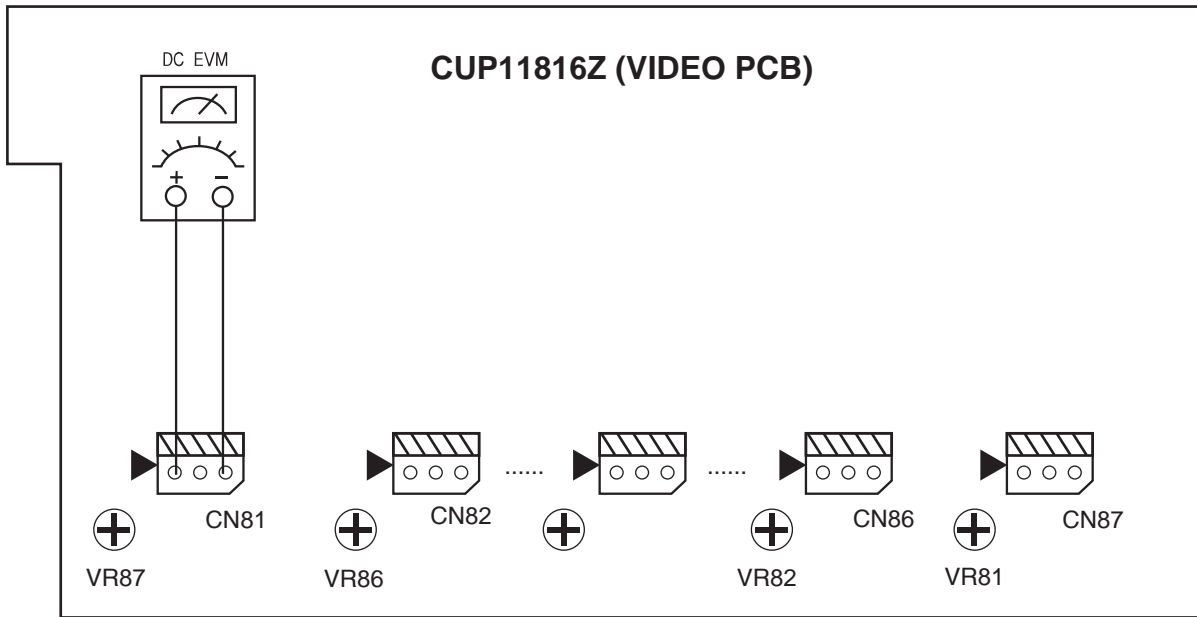

DC VOLTMETER.....Connect to CN81,CN82,CN83,CN84,CN85,CN86,CN87

NO.	Channel	Adjust for	Adjustment
1	Front Left	25.92mV (±5%)	VR83
2	Front Right	25.92mV (±5%)	VR84
3	Center	25.92mV (±5%)	VR85
4	Surround Left	25.92mV (±5%)	VR86
5	Surround Right	25.92mV (±5%)	VR87
6	Surround Back Left	25.92mV (±5%)	VR82
7	Surround Back Right	25.92mV (±5%)	VR81 (ONLY AVR240/340)

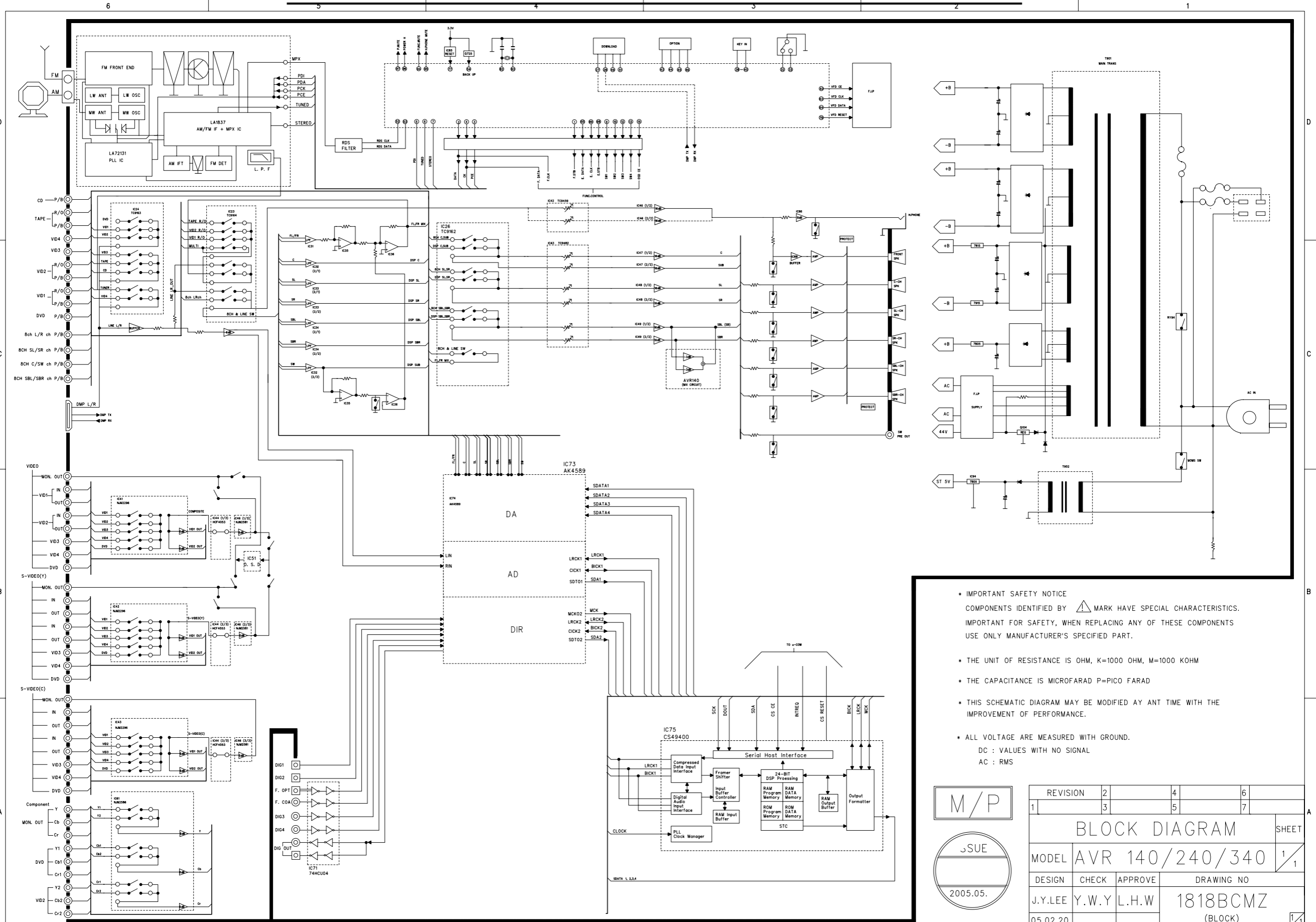

* IMPORTANT SAFETY NOTICE
 COMPONENTS IDENTIFIED BY Δ MARK HAVE SPECIAL CHARACTERISTICS.
 IMPORTANT FOR SAFETY, WHEN REPLACING ANY OF THESE COMPONENTS
 USE ONLY MANUFACTURER'S SPECIFIED PART.

* THE UNIT OF RESISTANCE IS OHM, K=1000 OHM, M=1000 KOHM

* THE CAPACITANCE IS MICROFARAD P=PICO FARAD

* THIS SCHEMATIC DIAGRAM MAY BE MODIFIED AT ANY TIME WITH THE
 IMPROVEMENT OF PERFORMANCE.

* ALL VOLTAGE ARE MEASURED WITH GROUND.
 DC : VALUES WITH NO SIGNAL
 AC : RMS

M/P

SUE
 2005.05.

REVISION		2	4	6
1	3	5	7	
BLOCK DIAGRAM				
MODEL	AVR 140/240/340			SHEET 1/1
DESIGN	CHECK	APPROVE	DRAWING NO	
J.Y.LEE	Y.W.Y	L.H.W	1818BCMZ	
05.02.20			(BLOCK)	

AVR340 Electrical Parts List					
Ref. Designator	Part Number	Description		Qty	
FRONT PCB ASSY (CUP11818Y)					
<i>Capacitors</i>					
C703	HCBS1H821KBT	CAP , CERAMIC	820PF 50V K	1	EA
C704	CCEA1VH100T	CAP , ELECT	10UF 35V	1	EA
C712	CCEA1HH1R0T	CAP , ELECT	1UF 50V	1	EA
C713	HCBS1H223ZFT	CAP , CERAMIC	0.022UF 50V Z	1	EA
C714	HCBS1H151KBT	CAP , CERAMIC	150PF 50V K	1	EA
C715	CCEA1HH4R7T	CAP , ELECT	4.7UF 50V	1	EA
C716	CCEA1CH331T	CAP , ELECT	330UF 16V	1	EA
C723	HCBS1H104ZFT	CAP , CERAMIC	0.1UF 50V Z	1	EA
C725	HCBS1H473ZFT	CAP , CERAMIC	0.047UF 50V Z	1	EA
C726	CCEA1CH101T	CAP , ELECT	100UF 16V	1	EA
C728	HCBS1H104ZFT	CAP , CERAMIC	0.1UF 50V Z	1	EA
C729	CCKT1H473ZF	CAP , CERAMIC	0.047UF 50V ZF	1	EA
C731	CCEA1HH100T	CAP , ELECT	10UF 50V	1	EA
C735	CCEA1CH101T	CAP , ELECT	100UF 16V	1	EA
C736	HCBS1H223ZFT	CAP , CERAMIC	0.022UF 50V Z	1	EA
C737	HCBS1H180JCT	CAP , CERAMIC	18PF 50V J	1	EA
C738	HCBS1H180JCT	CAP , CERAMIC	18PF 50V J	1	EA
C739	CCEA1AH221T	CAP , ELECT	220UF/10V	1	EA
C740	CCEA1VH100T	CAP , ELECT	10UF 35V	1	EA
C793	HCBS1H104ZFT	CAP , CERAMIC	0.1UF 50V Z	1	EA
C794	HCBS1H102KBT	CAP , CERAMIC	1000PF 50V B	1	EA
C795	HCBS1H221KBT	CAP , CERAMIC	220PF 50V K	1	EA
C796	HCBS1H101KBT	CAP , CERAMIC	100PF 50V K	1	EA
C798	HCBS1H223ZFT	CAP , CERAMIC	0.022UF 50V Z	1	EA
C799	CCEA1CH101T	CAP , ELECT	100UF 16V	1	EA
C859	HCBS1H223ZFT	CAP , CERAMIC	0.022UF 50V Z	1	EA
C860	HCBS1H223ZFT	CAP , CERAMIC	0.022UF 50V Z	1	EA
C861	HCBS1H223ZFT	CAP , CERAMIC	0.022UF 50V Z	1	EA
C875	HCBS1H101KBT	CAP , CERAMIC	100PF 50V K	1	EA
C876	HCBS1H101KBT	CAP , CERAMIC	100PF 50V K	1	EA
C877	HCBS1H473ZFT	CAP , CERAMIC	0.047UF 50V Z	1	EA
C878	HCBS1H473ZFT	CAP , CERAMIC	0.047UF 50V Z	1	EA
C882	HCBS1H104ZFT	CAP , CERAMIC	0.1UF 50V Z	1	EA
C886	CCEA0JH102T	CAP , ELECT	1000UF 6.3V	1	EA
C891	HCBS1H223ZFT	CAP , CERAMIC	0.022UF 50V Z	1	EA
C892	HCBS1H223ZFT	CAP , CERAMIC	0.022UF 50V Z	1	EA
C893	HCBS1H223ZFT	CAP , CERAMIC	0.022UF 50V Z	1	EA
C896	HCBS1H223ZFT	CAP , CERAMIC	0.022UF 50V Z	1	EA
C897	CCEA1AH471T	CAP , ELECT	470UF 10V	1	EA
C901	HCBS1H390JT	CAP , CERAMIC	39PF 50V J	1	EA
C903	CCEA1HKS2R2T	CAP , ELECT	2.2UF 50V KS	1	EA
C905	CCEA1HKS2R2T	CAP , ELECT	2.2UF 50V KS	1	EA
C894	CCEA1CH101T	CAP , ELECT	100UF 16V	1	EA
<i>Semiconductors</i>					
D724	HVD1SS133MT	DIODE	1SS133	1	EA
D728	HVD1SS133MT	DIODE	1SS133	1	EA
D729	HVD1SS133MT	DIODE	1SS133	1	EA
D730	HVD1SS133MT	DIODE	1SS133	1	EA
D778	KVD1N4003ST	DIODE	1N4003	1	EA
D779	HVD1SS133MT	DIODE	1SS133	1	EA
D780	HVD1SS133MT	DIODE	1SS133	1	EA
D781	HVD1SS133MT	DIODE	1SS133	1	EA
D782	KVD1N4003ST	DIODE	1N4003	1	EA
D783	HVD1SS133MT	DIODE	1SS133	1	EA
IC87	HVIRE5VL28CATZ	IC , RESET (RE5VL28CATZ)	RICOH	1	EA

Ref. Designator	Part Number	Description		Qty	
FRONT PCB ASSY (CUP11818Y)					
Q701	HVTKRC107MT	TRANSISTOR	KRC107M	1	EA
Q702	HVTKRA107MT	TRANSISTOR	KRA107M	1	EA
Q705	HVTKRC107MT	TRANSISTOR	KRC107M	1	EA
Q722	HVTKRA107MT	TRANSISTOR	KRA107M	1	EA
Q724	HVTKRC107MT	TRANSISTOR	KRC107M	1	EA
Q725	HVTKRC107MT	TRANSISTOR	KRC107M	1	EA
Q726	HVTKRC107MT	TRANSISTOR	KRC107M	1	EA
Q727	HVTKRC107MT	TRANSISTOR	KRC107M	1	EA
Q728	HVTKRC107MT	TRANSISTOR	KRC107M	1	EA
Q729	HVTKRC107MT	TRANSISTOR	KRC107M	1	EA
Q731	HVTKSA1175YT	TRANSISTOR	SA1175YT	2	EA
Q733	HVTKSC2785YT	TRANSISTOR	SC2785YT	3	EA
Q738	HVTKRC107MT	TRANSISTOR	KRC107M	1	EA
Q739	HVTKTA1271YT	TRANSISTOR	KTA1271Y	1	EA
Q740	HVTKRC107MT	TRANSISTOR	KRC107M	1	EA
Q741	HVTKRC107MT	TRANSISTOR	KRC107M	1	EA
Q743	HVTKRA107MT	TRANSISTOR	KRA107M	1	EA
Q799	HVTKSC2785YT	TRANSISTOR	SC2785YT	1	EA
IC72	BVIMB90F482APFG340	IC , FLASH U-COM (MB90F482APFG)	FUJITSU	1	EA
IC73	HRVNJL34H380A	SENSOR , REMOTE (NJL34H380A)	SENSOR	1	EA
IC75	HVI74ACT04MTR	I.C , HEX (74ACT04)	FAIRCHILD	1	EA
IC83	HVI74ACT04MTR	I.C , HEX (74ACT04)	FAIRCHILD	1	EA
IC84	HVI74ACT04MTR	I.C , HEX (74ACT04)	FAIRCHILD	1	EA
IC85	HVIRH5VT18C	I.C , RESET (RH5VT18C)	RICOH	1	EA
<i>Resistors</i>					
R700	CRD20TJ102T	RES , CARBON	1K OHM 1/5W J	1	EA
R701	CRD20TJ103T	RES , CARBON	10K OHM 1/5W J	1	EA
R704	CRD20TJ100T	RES , CARBON	10 OHM 1/5W J	1	EA
R709	CRD20TJ470T	RES , CARBON	47 OHM 1/5W J	1	EA
R710	CRD20TJ470T	RES , CARBON	47 OHM 1/5W J	1	EA
R711	CRD20TJ470T	RES , CARBON	47 OHM 1/5W J	1	EA
R712	CRD20TJ102T	RES , CARBON	1K OHM 1/5W J	1	EA
R713	CRD20TJ102T	RES , CARBON	1K OHM 1/5W J	1	EA
R714	CRD20TJ102T	RES , CARBON	1K OHM 1/5W J	1	EA
R716	CRD20TJ102T	RES , CARBON	1K OHM 1/5W J	1	EA
R718	CRD20TJ222T	RES , CARBON	2.2K OHM 1/5W J	1	EA
R729	CRD20TJ103T	RES , CARBON	10K OHM 1/5W J	1	EA
R730	CRD20TJ112T	RES , CARBON	1.1K OHM 1/5W J	1	EA
R731	CRD20TJ223T	RES , CARBON	22K OHM 1/5W J	1	EA
R732	CRD20TJ222T	RES , CARBON	2.2K OHM 1/5W J	1	EA
R733	CRD20TJ272T	RES , CARBON	2.7K OHM 1/5W J	1	EA
R734	CRD20TJ103T	RES , CARBON	10K OHM 1/5W J	1	EA
R735	CRD20TJ103T	RES , CARBON	10K OHM 1/5W J	1	EA
R736	CRD20TJ272T	RES , CARBON	2.7K OHM 1/5W J	1	EA
R737	CRD20TJ100T	RES , CARBON	10 OHM 1/5W J	1	EA
R738	CRD20TJ103T	RES , CARBON	10K OHM 1/5W J	1	EA
R739	CRD20TJ103T	RES , CARBON	10K OHM 1/5W J	1	EA
R740	CRD20TJ103T	RES , CARBON	10K OHM 1/5W J	1	EA
R742	CRD20TJ103T	RES , CARBON	10K OHM 1/5W J	1	EA
R743	CRD20TJ103T	RES , CARBON	10K OHM 1/5W J	1	EA
R747	CRD20TJ103T	RES , CARBON	10K OHM 1/5W J	1	EA
R748	CRD20TJ223T	RES , CARBON	22K OHM 1/5W J	1	EA
R749	CRD20TJ223T	RES , CARBON	22K OHM 1/5W J	1	EA
R750	CRD20TJ223T	RES , CARBON	22K OHM 1/5W J	1	EA
R771	CRD20TJ103T	RES , CARBON	10K OHM 1/5W J	1	EA
R772	CRD20TJ103T	RES , CARBON	10K OHM 1/5W J	1	EA
R773	CRD20TJ103T	RES , CARBON	10K OHM 1/5W J	1	EA
R780	CRD20TJ100T	RES , CARBON	10 OHM 1/5W J	1	EA
R781	CRD20TJ123T	RES , CARBON	12K OHM 1/5W J	1	EA

Ref. Designator	Part Number	Description		Qty	
FRONT PCB ASSY (CUP11818Y)					
R782	CRD20TJ103T	RES , CARBON	10K OHM 1/5W J	1	EA
R786	CRD20TJ152T	RES , CARBON	1.5K OHM 1/5W J	1	EA
R787	CRD20TJ101T	RES , CARBON	100 OHM 1/5W J	1	EA
R789	CRD20TJ102T	RES , CARBON	1K OHM 1/5W J	1	EA
R790	CRD20TJ105T	RES , CARBON	1M OHM 1/5W J	1	EA
R791	CRD20TJ822T	RES , CARBON	8.2K OHM 1/5W J	1	EA
R792	CRD20TJ102T	RES , CARBON	1K OHM 1/5W J	1	EA
R794	CRD20TJ103T	RES , CARBON	10K OHM 1/5W J	1	EA
R795	CRD20TJ101T	RES , CARBON	1K OHM 1/5W J	1	EA
R796	CRD20TJ102T	RES , CARBON	1K OHM 1/5W J	1	EA
R797	CRD20TJ1R0T	RES , CARBON	1 OHM 1/5W J	1	EA
R798	CRD20TJ1R0T	RES , CARBON	1 OHM 1/5W J	1	EA
R820	CRD20TJ103T	RES , CARBON	10K OHM 1/5W J	1	EA
R821	CRD20TJ103T	RES , CARBON	10K OHM 1/5W J	1	EA
R824	CRD20TJ221T	RES , CARBON	220 OHM 1/5W J	1	EA
R825	CRD20TJ681T	RES , CARBON	680 OHM 1/5W J	1	EA
R881	CRD20TJ103T	RES , CARBON	10K OHM 1/5W J	1	EA
R882	CRD20TJ103T	RES , CARBON	10K OHM 1/5W J	1	EA
R883	CRD20TJ103T	RES , CARBON	10K OHM 1/5W J	1	EA
R884	CRD20TJ103T	RES , CARBON	10K OHM 1/5W J	1	EA
R885	CRD20TJ103T	RES , CARBON	10K OHM 1/5W J	1	EA
R886	CRD20TJ103T	RES , CARBON	10K OHM 1/5W J	1	EA
R887	CRD20TJ103T	RES , CARBON	10K OHM 1/5W J	1	EA
R888	CRD20TJ103T	RES , CARBON	10K OHM 1/5W J	1	EA
R889	CRD20TJ103T	RES , CARBON	10K OHM 1/5W J	1	EA
R890	CRD20TJ103T	RES , CARBON	10K OHM 1/5W J	1	EA
R891	CRD20TJ103T	RES , CARBON	10K OHM 1/5W J	1	EA
R892	CRD20TJ222T	RES , CARBON	2.2K OHM 1/5W J	1	EA
R893	CRD20TJ333T	RES , CARBON	33K OHM 1/5W J	1	EA
R913	CRD20TJ102T	RES , CARBON	1K OHM 1/5W J	1	EA
R915	CRD20TJ473T	RES , CARBON	47K OHM 1/5W J	1	EA
<i>Miscellaneous</i>					
L702	HLQ02C100KT	COIL , AXAIL	10UH	1	EA
BAT1	HABGP40BVH3A3H	BATTERY , RECHARGEABLE	BATTERY	1	EA
BK71	CMD1A209	BRACKET , FLT	BRACKET	1	EA
BK72	CMD1A209	BRACKET , FLT	BRACKET	1	EA
BK73	CMD1A387	BRACKET , PCB	BRACKET	1	EA
BK74	CMD1A209	BRACKET , FLT	BRACKET	1	EA
BN12	CWB2B903450EN	WIRE ASS'Y	WIRE	1	EA
BN15	CWB2B910150EN	WIRE ASS'Y	WIRE	1	EA
BN62	CWB2B904370EN	WIRE ASS'Y	WIRE	1	EA
BN72	HJP32GA179ZJ	CONN,FFC 1M/M 32P STR,SMD_JST	CONNECTOR	1	EA
BN80	CWB2B911420EW	WIRE ASS'Y	WIRE	1	EA
BN81	CWB2B908250BM	WIRE , ASS'Y	WIRE	1	EA
BN84	CWB2B905080EN	WIRE ASS'Y	WIRE	1	EA
BN85	CWB2B903090EN	WIRE ASS'Y	WIRE	1	EA
BN88	CWB2B904070EN	WIRE ASS'Y	WIRE	1	EA
CN89	CJP05GA19ZY	WAFER, STRAIGHT, 5PIN	WIRE	1	EA
FIP1	HFLHCA18ML03	F.I.P	FIP	1	EA
JW85	CWE8202070AA	WIRE ASS'Y	WIRE	1	EA
X701	HOX05000E160C	CRYSTAL	5Mhz	1	EA
PCB , MOMS (CUP11818-5)					
SW1	CSH1A008ZV	SW , PUSH (MOMS)	MOMS SWITCH	1	EA
CN86	KJP02GA89ZM	WAFER	WIRE	1	EA

Ref. Designator	Part Number	Description		Qty	
PCB , POWER KEY (CUP11818-6)					
CN88	CJP04GA19ZY	WAFER, STRAIGHT, 4PIN	WIRE	1	EA
D723	CVD50BOBBWGA	L.E.D , 2 COLOR (ORG , BLUE)	L.E.D	1	EA
S701	HST1A020ZT	SW , TACT	1A020	1	EA
PCB , DIGITAL INPUT (FRONT) (CUP11818-8)					
BN18	CWZAVR125BN18	WIRE ASS'Y (SHIELD)	WIRE	1	EA
IC76	HVI74HCU04AFNG	I.C , INVERTER (74HCU04)	TOSHIBA	1	EA
JK81	CJJ4M041Y	JACK , BOARD (COAX)	BOARD	1	EA
JK82	HJSTORX177L	MODULE , OPTICAL(RX)	OPTICAL JACK	1	EA
JW83	CWE8202150RV	WIRE ASS'Y	WIRE	1	EA
C807	CCFT1H104ZF	CAP , SEMICONDUCTOR	0.1UF 50V ZF	1	EA
C808	CCKT1H181KB	CAP , CERAMIC	180PF 50V KB	1	EA
C809	CCEA1AH471T	CAP , ELECT	470UF 10V	1	EA
C812	HCBS1H104ZFT	CAP , CERAMIC	0.1UF 50V Z	1	EA
C817	HCBS1H100JCT	CAP , CERAMIC	10PF 50V J	1	EA
R805	CRD20TJ104T	RES , CARBON	100K OHM 1/5W J	1	EA
R806	CRD20TJ472T	RES , CARBON	4.7K OHM 1/5W J	1	EA
R869	CRD20TJ750T	RES , CARBON	75 OHM 1/5W J	1	EA
R875	CRD20TJ103T	RES , CARBON	10K OHM 1/5W J	1	EA
PCB , HEADPHONE (CUP11818-4)					
BN92	CWB2B905080EN	WIRE ASS'Y	WIRE		
JK83	CJJ2E026Z	JACK , HEADPHONE(SILVER PLATE)	HEADPHONE JACK	1	EA
C783	HCBS1H104ZFT	CAP , CERAMIC	0.1UF 50V Z	1	EA
D786	HVD1SS133MT	DIODE	1SS133	1	EA
D787	HVD1SS133MT	DIODE	1SS133	1	EA
PCB , FRONT PANEL KEY (CUP11818-2)					
<i>Capacitors</i>					
C720	HCBS1H181KBT	CAP , CERAMIC	180PF 50V K	1	EA
C721	HCBS1H181KBT	CAP , CERAMIC	180PF 50V K	1	EA
C730	CCFT1H104ZF	CAP , SEMICONDUCTOR	0.1UF 50V ZF	1	EA
C719	HCBS1H181KBT	CAP , CERAMIC	180PF 50V K	1	EA
<i>Resistors</i>					
R744	CRD20TF1002T	RES , CARBON	10K F 1/5W	1	EA
R745	CRD20TF1002T	RES , CARBON	10K F 1/5W	1	EA
R746	CRD20TF1002T	RES , CARBON	10K F 1/5W	1	EA
R753	CRD20TJ102T	RES , CARBON	1K OHM 1/5W J	1	EA
R754	CRD20TJ152T	RES , CARBON	1.5K OHM 1/5W J	1	EA
R755	CRD20TJ182T	RES , CARBON	1.8K OHM 1/5W J	1	EA
R756	CRD20TJ272T	RES , CARBON	2.7K OHM 1/5W J	1	EA
R757	CRD20TJ332T	RES , CARBON	3.3K OHM 1/5W J	1	EA
R758	CRD20TJ562T	RES , CARBON	5.6K OHM 1/5W J	1	EA
R759	CRD20TJ102T	RES , CARBON	1K OHM 1/5W J	1	EA
R760	CRD20TJ152T	RES , CARBON	1.5K OHM 1/5W J	1	EA
R761	CRD20TJ182T	RES , CARBON	1.8K OHM 1/5W J	1	EA
R762	CRD20TJ272T	RES , CARBON	2.7K OHM 1/5W J	1	EA
R763	CRD20TJ332T	RES , CARBON	3.3K OHM 1/5W J	1	EA
R764	CRD20TJ562T	RES , CARBON	5.6K OHM 1/5W J	1	EA
R765	CRD20TJ752T	RES , CARBON	7.5K OHM 1/5W J	1	EA
R766	CRD20TJ102T	RES , CARBON	1K OHM 1/5W J	1	EA
R767	CRD20TJ152T	RES , CARBON	1.5K OHM 1/5W J	1	EA
R768	CRD20TJ182T	RES , CARBON	1.8K OHM 1/5W J	1	EA
R769	CRD20TJ272T	RES , CARBON	2.7K OHM 1/5W J	1	EA

Ref. Designator	Part Number	Description		Qty	
PCB , FRONT PANEL KEY (CUP11818-2)					
<i>Miscellaneous</i>					
BN89	CWB2B905080EN	WIRE ASS'Y	WIRE	1	EA
S702	HST1A020ZT	SW , TACT	1A020	1	EA
S703	HST1A020ZT	SW , TACT	1A020	1	EA
S704	HST1A020ZT	SW , TACT	1A020	1	EA
S705	HST1A020ZT	SW , TACT	1A020	1	EA
S706	HST1A020ZT	SW , TACT	1A020	1	EA
S707	HST1A020ZT	SW , TACT	1A020	1	EA
S708	HST1A020ZT	SW , TACT	1A020	1	EA
S709	HST1A020ZT	SW , TACT	1A020	1	EA
S710	HST1A020ZT	SW , TACT	1A020	1	EA
S711	HST1A020ZT	SW , TACT	1A020	1	EA
S712	HST1A020ZT	SW , TACT	1A020	1	EA
S713	HST1A020ZT	SW , TACT	1A020	1	EA
S714	HST1A020ZT	SW , TACT	1A020	1	EA
S715	HST1A020ZT	SW , TACT	1A020	1	EA
S716	HST1A020ZT	SW , TACT	1A020	1	EA
S717	HST1A020ZT	SW , TACT	1A020	1	EA
S718	HST1A020ZT	SW , TACT	1A020	1	EA
S719	HST1A020ZT	SW , TACT	1A020	1	EA
S720	HST1A020ZT	SW , TACT	1A020	1	EA
PCB , VOLUME ENCODER (CUP11818-3)					
<i>Capacitors</i>					
C805	HCBS1H223ZFT	CAP , CERAMIC	0.022UF 50V Z	1	EA
C806	HCBS1H223ZFT	CAP , CERAMIC	0.022UF 50V Z	1	EA
C841	CCEA1VH100T	CAP , ELECT	10UF 35V	1	EA
C842	CCEA1VH100T	CAP , ELECT	10UF 35V	1	EA
C843	CCEA1VH100T	CAP , ELECT	10UF 35V	1	EA
C855	HCBS1H101KBT	CAP , CERAMIC	100PF 50V K	1	EA
C856	HCBS1H101KBT	CAP , CERAMIC	100PF 50V K	1	EA
C857	HCBS1H104ZFT	CAP , CERAMIC	0.1UF 50V Z	1	EA
C862	HCBS1H101KBT	CAP , CERAMIC	100PF 50V K	1	EA
C863	HCBS1H101KBT	CAP , CERAMIC	100PF 50V K	1	EA
C874	HCBS1H101KBT	CAP , CERAMIC	100PF 50V K	1	EA
<i>Semiconductors</i>					
D701	CVD52CSBBCEAB2	BLUE L.E.D	L.E.D	1	EA
D703	CVD52CSBBCEAB2	BLUE L.E.D	L.E.D	1	EA
D705	CVD52CSBBCEAB2	BLUE L.E.D	L.E.D	1	EA
D774	HVD1SS133MT	DIODE	1SS133	1	EA
<i>Resistors</i>					
VR74	CSR2A037Z	ENCODER	ENCODER	1	EA
R705	CRD20TJ820T	RES , CARBON	82 OHM 1/5W J	1	EA
R706	CRD20TJ820T	RES , CARBON	82 OHM 1/5W J	1	EA
R708	CRD20TJ820T	RES , CARBON	82 OHM 1/5W J	1	EA
R864	CRD20TJ272T	RES , CARBON	2.7K OHM 1/5W J	1	EA
R865	CRD20TJ101T	RES , CARBON	100 OHM 1/5W J	1	EA
R866	CRD20TJ272T	RES , CARBON	2.7K OHM 1/5W J	1	EA
R871	CRD20TJ104T	RES , CARBON	100K OHM 1/5W J	1	EA
R872	CRD20TJ104T	RES , CARBON	100K OHM 1/5W J	1	EA
R873	CRD20TJ471T	RES , CARBON	470 OHM 1/5W J	1	EA
R874	CRD20TJ471T	RES , CARBON	470 OHM 1/5W J	1	EA
R876	CRD20TJ750T	RES , CARBON	75 OHM 1/5W J	1	EA
R877	CRD20TJ750T	RES , CARBON	75 OHM 1/5W J	1	EA

Ref. Designator	Part Number	Description		Qty	
PCB , VOLUME ENCODER (CUP11818-3)					
R878	CRD20TJ750T	RES , CARBON	75 OHM 1/5W J	1	EA
<i>Miscellaneous</i>					
BN10	CWZAVR230BN10	WIRE ASS'Y (SHIELD)	WIRE	1	EA
BN41	CWZAVR130BN41	WIRE ASS'Y (SHIELD)	WIRE	1	EA
CN84	KJP05GB46ZM	WAFER	WIRE	1	EA
JK85	CJJ9M003Z	JACK , S-VIDEO	S-VIDEO JACK	1	EA
JK86	CJJ4S023Y	JACK , BOARD	BOARD	1	EA
JW84	CWE8202110RV	WIRE, ASS'Y	WIRE	1	EA
PCB , INTERFACE (CUP11818-7)					
BN94	KJP13GB99ZM	CONNECTOR	CONNECTOR	1	EA
BN95	KJP08GB99ZM	CONNECTOR , HOUSING	CONNECTOR	1	EA
CN11	KJP08GA98ZM	WAFER	WIRE	1	EA
CN12	KJP15GA98ZM	WAFER	WIRE	1	EA
CN13	CJP05GA19ZY	WAFER	WIRE	1	EA
CN16	CJP06GA19ZY	WAFER, STRAIGHT, 6PIN	WIRE	1	EA
CN79	CJP05GA19ZY	WAFER, STRAIGHT, 6PIN	WIRE	1	EA
IC88	HVINJM2068MDTE1	I.C , OP AMP (NJM2068)	JRC	1	EA
IC89	HVIHCF4053M013T	I.C , SWITCH (HCF4053)	JRC	1	EA
C810	CCEA1CH101T	CAP , ELECT	100UF 16V	1	EA
C811	CCEA1CH101T	CAP , ELECT	100UF 16V	1	EA
C813	CCEA1VH100T	CAP , ELECT	10UF 35V	1	EA
C814	CCEA1VH100T	CAP , ELECT	10UF 35V	1	EA
C815	HCBS1H223ZFT	CAP , CERAMIC	0.022UF 50V Z	1	EA
C816	HCBS1H223ZFT	CAP , CERAMIC	0.022UF 50V Z	1	EA
D788	HVDMTZJ5.6BT	DIODE ZENER	5.6V	1	EA
D789	HVDMTZJ5.6BT	DIODE ZENER	5.6V	1	EA
R808	CRD20TJ102T	RES , CARBON	1K OHM 1/5W J	1	EA
R809	CRD20TJ102T	RES , CARBON	1K OHM 1/5W J	1	EA
R810	CRD20TJ101T	RES , CARBON	100 OHM 1/5W J	1	EA
R811	CRD20TJ101T	RES , CARBON	100 OHM 1/5W J	1	EA
R813	CRD20TJ104T	RES , CARBON	100K OHM 1/5W J	1	EA
R814	CRD20TJ104T	RES , CARBON	100K OHM 1/5W J	1	EA
INPUT PCB (CUP11815-1)					
<i>Capacitors</i>					
C105	HCUS1H223KC	CAP , CHIP	2200PF	1	EA
C106	HCUS1H223KC	CAP , CHIP	2200PF	1	EA
C201	HCUS1H221JA	CAP , CHIP	220PF	1	EA
C202	HCUS1H221JA	CAP , CHIP	220PF	1	EA
C203	HCUS1H221JA	CAP , CHIP	220PF	1	EA
C204	HCUS1H221JA	CAP , CHIP	220PF	1	EA
C205	HCUS1H221JA	CAP , CHIP	220PF	1	EA
C206	HCUS1H221JA	CAP , CHIP	220PF	1	EA
C207	HCUS1H221JA	CAP , CHIP	220PF	1	EA
C208	HCUS1H221JA	CAP , CHIP	220PF	1	EA
C209	HCUS1H221JA	CAP , CHIP	220PF	1	EA
C210	HCUS1H221JA	CAP , CHIP	220PF	1	EA
C211	HCUS1H221JA	CAP , CHIP	220PF	1	EA
C212	HCUS1H221JA	CAP , CHIP	220PF	1	EA
C213	HCUS1H221JA	CAP , CHIP	220PF	1	EA
C214	HCUS1H221JA	CAP , CHIP	220PF	1	EA
C215	HCUS1H221JA	CAP , CHIP	220PF	1	EA
C216	HCUS1H221JA	CAP , CHIP	220PF	1	EA
C217	HCUS1H221JA	CAP , CHIP	220PF	1	EA
C218	HCUS1H221JA	CAP , CHIP	220PF	1	EA

Ref. Designator	Part Number	Description		Qty	
INPUT PCB (CUP11815-1)					
C219	HCUS1H221JA	CAP , CHIP	220PF	1	EA
C220	HCUS1H221JA	CAP , CHIP	220PF	1	EA
C221	HCUS1H221JA	CAP , CHIP	220PF	1	EA
C222	HCUS1H221JA	CAP , CHIP	220PF	1	EA
C223	HCUS1H221JA	CAP , CHIP	220PF	1	EA
C224	HCUS1H221JA	CAP , CHIP	220PF	1	EA
C225	HCUS1H221JA	CAP , CHIP	220PF	1	EA
C226	HCUS1H221JA	CAP , CHIP	220PF	1	EA
C233	HCUS1H181JA	CAP , CHIP	180PF	1	EA
C234	HCUS1H471JA	CAP , CHIP	470PF	1	EA
C235	HCUS1H223KC	CAP , CHIP	2200PF	1	EA
C236	HCUS1H223KC	CAP , CHIP	2200PF	1	EA
C241	HCUS1H181JA	CAP , CHIP	180PF	1	EA
C242	HCUS1H471JA	CAP , CHIP	470PF	1	EA
C253	HCUS1H181JA	CAP , CHIP	180PF	1	EA
C254	HCUS1H471JA	CAP , CHIP	470PF	1	EA
C255	HCUS1H223KC	CAP , CHIP	2200PF	1	EA
C256	HCUS1H223KC	CAP , CHIP	2200PF	1	EA
C270	HCUS1H181JA	CAP , CHIP	180PF	1	EA
C271	HCUS1H471JA	CAP , CHIP	470PF	1	EA
C291	HCUS1H104ZF	CAP , CHIP	0.1UF	1	EA
C292	HCUS1H104ZF	CAP , CHIP	0.1UF	1	EA
C293	HCUS1H104ZF	CAP , CHIP	0.1UF	1	EA
C294	HCUS1H104ZF	CAP , CHIP	0.1UF	1	EA
C295	HCUS1H104ZF	CAP , CHIP	0.1UF	1	EA
C296	HCUS1H104ZF	CAP , CHIP	0.1UF	1	EA
C297	HCUS1H104ZF	CAP , CHIP	0.1UF	1	EA
C298	HCUS1H104ZF	CAP , CHIP	0.1UF	1	EA
C309	HCUS1H332KC	CAP , CHIP	3300PF	1	EA
C310	HCUS1H332KC	CAP , CHIP	3300PF	1	EA
C311	HCUS1H332KC	CAP , CHIP	3300PF	1	EA
C312	HCUS1H332KC	CAP , CHIP	3300PF	1	EA
C313	HCUS1H332KC	CAP , CHIP	3300PF	1	EA
C314	HCUS1H332KC	CAP , CHIP	3300PF	1	EA
C315	HCUS1H332KC	CAP , CHIP	3300PF	1	EA
C316	HCUS1H332KC	CAP , CHIP	3300PF	1	EA
C317	HCUS1H223KC	CAP , CHIP	2200PF	1	EA
C318	HCUS1H223KC	CAP , CHIP	2200PF	1	EA
C319	HCUS1H223KC	CAP , CHIP	2200PF	1	EA
C320	HCUS1H223KC	CAP , CHIP	2200PF	1	EA
C321	HCUS1H561JA	CAP , CHIP	560PF	1	EA
C322	HCUS1H561JA	CAP , CHIP	560PF	1	EA
C323	HCUS1H561JA	CAP , CHIP	560PF	1	EA
C324	HCUS1H561JA	CAP , CHIP	560PF	1	EA
C325	HCUS1H561JA	CAP , CHIP	560PF	1	EA
C326	HCUS1H561JA	CAP , CHIP	560PF	1	EA
C327	HCUS1H561JA	CAP , CHIP	560PF	1	EA
C328	HCUS1H561JA	CAP , CHIP	560PF	1	EA
C329	HCUS1H561JA	CAP , CHIP	560PF	1	EA
C330	HCUS1H561JA	CAP , CHIP	560PF	1	EA
C331	HCUS1H561JA	CAP , CHIP	560PF	1	EA
C332	HCUS1H561JA	CAP , CHIP	560PF	1	EA
C333	HCUS1H561JA	CAP , CHIP	560PF	1	EA
C334	HCUS1H561JA	CAP , CHIP	560PF	1	EA
C335	HCUS1H561JA	CAP , CHIP	560PF	1	EA
C336	HCUS1H561JA	CAP , CHIP	560PF	1	EA
C337	HCUS1H223KC	CAP , CHIP	2200PF	1	EA
C338	HCUS1H223KC	CAP , CHIP	2200PF	1	EA
C339	HCUS1H223KC	CAP , CHIP	2200PF	1	EA
C340	HCUS1H223KC	CAP , CHIP	2200PF	1	EA
C350	HCUS1H332KC	CAP , CHIP	3300PF	1	EA

Ref. Designator	Part Number	Description		Qty	
INPUT PCB (CUP11815-1)					
C351	HCUS1H332KC	CAP , CHIP	3300PF	1	EA
C352	HCUS1H332KC	CAP , CHIP	3300PF	1	EA
C353	HCUS1H332KC	CAP , CHIP	3300PF	1	EA
C354	HCUS1H332KC	CAP , CHIP	3300PF	1	EA
C355	HCUS1H332KC	CAP , CHIP	3300PF	1	EA
C356	HCUS1H332KC	CAP , CHIP	3300PF	1	EA
C357	HCUS1H332KC	CAP , CHIP	3300PF	1	EA
C371	HCUS1H221JA	CAP , CHIP	220PF	1	EA
C372	HCUS1H221JA	CAP , CHIP	220PF	1	EA
C373	HCUS1H221JA	CAP , CHIP	220PF	1	EA
C374	HCUS1H221JA	CAP , CHIP	220PF	1	EA
C375	HCUS1H223KC	CAP , CHIP	2200PF	1	EA
C376	HCUS1H223KC	CAP , CHIP	2200PF	1	EA
C378	HCUS1H223KC	CAP , CHIP	2200PF	1	EA
C379	HCUS1H223KC	CAP , CHIP	2200PF	1	EA
C381	HCUS1H561JA	CAP , CHIP	560PF	1	EA
C382	HCUS1H223KC	CAP , CHIP	2200PF	1	EA
C383	HCUS1H223KC	CAP , CHIP	2200PF	1	EA
C390	HCUS1H471JA	CAP , CHIP	470PF	1	EA
C391	HCUS1H471JA	CAP , CHIP	470PF	1	EA
C392	HCUS1H471JA	CAP , CHIP	470PF	1	EA
C393	HCUS1H471JA	CAP , CHIP	470PF	1	EA
C394	HCUS1H471JA	CAP , CHIP	470PF	1	EA
C395	HCUS1H471JA	CAP , CHIP	470PF	1	EA
C396	HCUS1H471JA	CAP , CHIP	470PF	1	EA
C397	HCUS1H471JA	CAP , CHIP	470PF	1	EA
C413	HCUS1H223KC	CAP , CHIP	2200PF	1	EA
C414	HCUS1H223KC	CAP , CHIP	2200PF	1	EA
C415	HCUS1H223KC	CAP , CHIP	2200PF	1	EA
C416	HCUS1H223KC	CAP , CHIP	2200PF	1	EA
C417	HCUS1H223KC	CAP , CHIP	2200PF	1	EA
C418	HCUS1H223KC	CAP , CHIP	2200PF	1	EA
C419	HCUS1H223KC	CAP , CHIP	2200PF	1	EA
C420	HCUS1H223KC	CAP , CHIP	2200PF	1	EA
C421	HCUS1H151JA	CAP , CHIP , 150PFJA	150PF	1	EA
C422	HCUS1H151JA	CAP , CHIP , 150PFJA	150PF	1	EA
C425	HCUS1H151JA	CAP , CHIP , 150PFJA	150PF	1	EA
C426	HCUS1H102KC	CAP , CHIP	1000PF	1	EA
C427	HCUS1H151JA	CAP , CHIP , 150PFJA	150PF	1	EA
C428	HCUS1H151JA	CAP , CHIP , 150PFJA	150PF	1	EA
C429	HCUS1H151JA	CAP , CHIP , 150PFJA	150PF	1	EA
C430	HCUS1H151JA	CAP , CHIP , 150PFJA	150PF	1	EA
C471	HCUS1H181JA	CAP , CHIP	180PF	1	EA
C472	HCUS1H181JA	CAP , CHIP	180PF	1	EA
C473	HCUS1H181JA	CAP , CHIP	180PF	1	EA
C474	HCUS1H181JA	CAP , CHIP	180PF	1	EA
C521	HCUS1H103KC	CAP , CHIP	0.01UF	1	EA
C523	HCUS1H103KC	CAP , CHIP	0.01UF	1	EA
C530	HCUS1H390JA	CAP , CHIP	39PF	1	EA
C531	HCUS1H390JA	CAP , CHIP	39PF	1	EA
C538	HCUS1H100JA	CAP , CHIP	10PF	1	EA
C539	HCUS1H224ZF	CAP , CHIP	0.22UF	1	EA
C540	HCUS1H222KC	CAP , CHIP	2200PF	1	EA
C541	HCUS1H103KC	CAP , CHIP	0.01UF	1	EA
C543	HCUS1H104ZF	CAP , CHIP	0.1UF	1	EA
C544	HCUS1H223KC	CAP , CHIP	2200PF	1	EA
C546	HCUS1H104ZF	CAP , CHIP	0.1UF	1	EA
C547	HCUS1H104ZF	CAP , CHIP	0.1UF	1	EA
C548	HCUS1H104ZF	CAP , CHIP	0.1UF	1	EA
C549	HCUS1H104ZF	CAP , CHIP	0.1UF	1	EA
C550	HCUS1H104ZF	CAP , CHIP	0.1UF	1	EA

Ref. Designator	Part Number	Description		Qty	
INPUT PCB (CUP11815-1)					
C551	HCUS1H104ZF	CAP , CHIP	0.1UF	1	EA
C552	HCUS1H104ZF	CAP , CHIP	0.1UF	1	EA
C553	HCUS1H103KC	CAP , CHIP	0.01UF	1	EA
C556	HCUS1H220JA	CAP , CHIP	22PF	1	EA
C557	HCUS1H220JA	CAP , CHIP	22PF	1	EA
C558	CCUS1H9R0JA	CAP , CHIP	9PF	1	EA
C560	HCUS1H103KC	CAP , CHIP	0.01UF	1	EA
C564	HCUS1H103KC	CAP , CHIP	0.01UF	1	EA
C565	HCUS1H103KC	CAP , CHIP	0.01UF	1	EA
C566	HCUS1H103KC	CAP , CHIP	0.01UF	1	EA
C567	HCUS1H103KC	CAP , CHIP	0.01UF	1	EA
C568	HCUS1H103KC	CAP , CHIP	0.01UF	1	EA
C569	HCUS1H103KC	CAP , CHIP	0.01UF	1	EA
C570	HCUS1H103KC	CAP , CHIP	0.01UF	1	EA
C571	HCUS1H103KC	CAP , CHIP	0.01UF	1	EA
C572	HCUS1H104ZF	CAP , CHIP	0.1UF	1	EA
C573	HCUS1H100JA	CAP , CHIP	10PF	1	EA
C574	HCUS1H102KC	CAP , CHIP	1000PF	1	EA
C575	HCUS1H103KC	CAP , CHIP	0.01UF	1	EA
C576	HCUS1H103KC	CAP , CHIP	0.01UF	1	EA
C577	HCUS1H181JA	CAP , CHIP	180PF	1	EA
C579	HCUS1H390JA	CAP , CHIP	39PF	1	EA
C580	HCUS1H390JA	CAP , CHIP	39PF	1	EA
C581	HCUS1H104ZF	CAP , CHIP	0.1UF	1	EA
C582	HCUS1H104ZF	CAP , CHIP	0.1UF	1	EA
C584	HCUS1H510JA	CAP , CHIP , 51PF JA	51PF	1	EA
C587	HCUS1H220JA	CAP , CHIP	22PF	1	EA
C590	HCUS1H104ZF	CAP , CHIP	0.1UF	1	EA
C591	HCUS1H151JA	CAP , CHIP , 150PFJA	150PF	1	EA
C599	HCUS1H390JA	CAP , CHIP	39PF	1	EA
C600	HCUS1H390JA	CAP , CHIP	39PF	1	EA
C701	HCUS1H330JA	CAP , CHIP	33PF	1	EA
C702	HCUS1H330JA	CAP , CHIP	33PF	1	EA
C704	HCUS1H104ZF	CAP , CHIP	0.1UF	1	EA
C705	HCUS1H104ZF	CAP , CHIP	0.1UF	1	EA
C707	HCUS1H102KC	CAP , CHIP	1000PF	1	EA
C708	HCUS1H104ZF	CAP , CHIP	0.1UF	1	EA
C718	HCUS1H104ZF	CAP , CHIP	0.1UF	1	EA
C719	HCUS1H104ZF	CAP , CHIP	0.1UF	1	EA
C722	HCUS1H104ZF	CAP , CHIP	0.1UF	1	EA
C723	HCUS1H473ZF	CAP , CHIP	0.047UF	1	EA
C725	HCUS1H104ZF	CAP , CHIP	0.1UF	1	EA
C727	HCUS1H104ZF	CAP , CHIP	0.1UF	1	EA
C729	HCUS1H104ZF	CAP , CHIP	0.1UF	1	EA
C731	HCUS1H104ZF	CAP , CHIP	0.1UF	1	EA
C733	HCUS1H104ZF	CAP , CHIP	0.1UF	1	EA
C734	HCUS1H122KC	CAP , CHIP	1200PF	1	EA
C735	HCUS1H680JA	CAP , CHIP	68PF	1	EA
C738	HCUS1C105ZF	CAP , CHIP	1UF	1	EA
C739	HCUS1H103KC	CAP , CHIP	0.01UF	1	EA
C740	HCUS1H104ZF	CAP , CHIP	0.1UF	1	EA
C742	HCUS1H104ZF	CAP , CHIP	0.1UF	1	EA
C743	HCUS1H104ZF	CAP , CHIP	0.1UF	1	EA
C744	HCUS1H104ZF	CAP , CHIP	0.1UF	1	EA
C745	HCUS1H104ZF	CAP , CHIP	0.1UF	1	EA
C747	HCUS1H104ZF	CAP , CHIP	0.1UF	1	EA
C748	HCUS1H104ZF	CAP , CHIP	0.1UF	1	EA
C750	HCUS1H104ZF	CAP , CHIP	0.1UF	1	EA
C751	HCUS1H104ZF	CAP , CHIP	0.1UF	1	EA
C752	HCUS1H104ZF	CAP , CHIP	0.1UF	1	EA
C754	HCUS1H104ZF	CAP , CHIP	0.1UF	1	EA

Ref. Designator	Part Number	Description		Qty	
INPUT PCB (CUP11815-1)					
C756	HCUS1H104ZF	CAP , CHIP	0.1UF	1	EA
C757	HCUS1H104ZF	CAP , CHIP	0.1UF	1	EA
C758	HCUS1H104ZF	CAP , CHIP	0.1UF	1	EA
C759	HCUS1H104ZF	CAP , CHIP	0.1UF	1	EA
C760	HCUS1H104ZF	CAP , CHIP	0.1UF	1	EA
C761	HCUS1H104ZF	CAP , CHIP	0.1UF	1	EA
C762	HCUS1H104ZF	CAP , CHIP	0.1UF	1	EA
C763	HCUS1H104ZF	CAP , CHIP	0.1UF	1	EA
C765	HCUS1H104ZF	CAP , CHIP	0.1UF	1	EA
C767	HCUS1H104ZF	CAP , CHIP	0.1UF	1	EA
C768	HCUS1H104ZF	CAP , CHIP	0.1UF	1	EA
C769	HCUS1H104ZF	CAP , CHIP	0.1UF	1	EA
C770	HCUS1H104ZF	CAP , CHIP	0.1UF	1	EA
C771	HCUS1H104ZF	CAP , CHIP	0.1UF	1	EA
C772	HCUS1H104ZF	CAP , CHIP	0.1UF	1	EA
C773	HCUS1H104ZF	CAP , CHIP	0.1UF	1	EA
C103	CCEA1VH100T	CAP , ELECT	10UF 35V	1	EA
C104	CCEA1VH100T	CAP , ELECT	10UF 35V	1	EA
C231	CCEA1EH470T	CAP , ELECT	47UF 25V	1	EA
C232	CCEA1EH470T	CAP , ELECT	47UF 25V	1	EA
C251	CCEA1EH470T	CAP , ELECT	47UF 25V	1	EA
C252	CCEA1EH470T	CAP , ELECT	47UF 25V	1	EA
C261	CCEA1EH470T	CAP , ELECT	47UF 25V	1	EA
C262	CCEA1EH470T	CAP , ELECT	47UF 25V	1	EA
C263	CCEA1VH100T	CAP , ELECT	10UF 35V	1	EA
C264	CCEA1VH100T	CAP , ELECT	10UF 35V	1	EA
C265	CCEA1VH100T	CAP , ELECT	10UF 35V	1	EA
C267	CCEA1VH100T	CAP , ELECT	10UF 35V	1	EA
C268	CCEA1VH100T	CAP , ELECT	10UF 35V	1	EA
C269	CCEA1VH100T	CAP , ELECT	10UF 35V	1	EA
C341	CCEA1VH100T	CAP , ELECT	10UF 35V	1	EA
C342	CCEA1VH100T	CAP , ELECT	10UF 35V	1	EA
C343	CCEA1VH100T	CAP , ELECT	10UF 35V	1	EA
C344	CCEA1VH100T	CAP , ELECT	10UF 35V	1	EA
C345	CCEA1VH100T	CAP , ELECT	10UF 35V	1	EA
C346	CCEA1VH100T	CAP , ELECT	10UF 35V	1	EA
C347	CCEA1VH100T	CAP , ELECT	10UF 35V	1	EA
C348	CCEA1VH100T	CAP , ELECT	10UF 35V	1	EA
C403	CCEA1VH100T	CAP , ELECT	10UF 35V	1	EA
C404	CCEA1VH100T	CAP , ELECT	10UF 35V	1	EA
C405	CCEA1VH100T	CAP , ELECT	10UF 35V	1	EA
C406	CCEA1VH100T	CAP , ELECT	10UF 35V	1	EA
C407	CCEA1VH100T	CAP , ELECT	10UF 35V	1	EA
C408	CCEA1VH100T	CAP , ELECT	10UF 35V	1	EA
C409	CCEA1VH100T	CAP , ELECT	10UF 35V	1	EA
C410	CCEA1VH100T	CAP , ELECT	10UF 35V	1	EA
C433	CCEA1EH470T	CAP , ELECT	47UF 25V	1	EA
C434	CCEA1EH470T	CAP , ELECT	47UF 25V	1	EA
C435	CCEA1EH470T	CAP , ELECT	47UF 25V	1	EA
C436	CCEA1EH470T	CAP , ELECT	47UF 25V	1	EA
C437	CCEA1EH470T	CAP , ELECT	47UF 25V	1	EA
C438	CCEA1EH470T	CAP , ELECT	47UF 25V	1	EA
C439	CCEA1EH470T	CAP , ELECT	47UF 25V	1	EA
C440	CCEA1EH470T	CAP , ELECT	47UF 25V	1	EA
C453	CCEA1VH100T	CAP , ELECT	10UF 35V	1	EA
C454	CCEA1VH100T	CAP , ELECT	10UF 35V	1	EA
C455	CCEA1VH100T	CAP , ELECT	10UF 35V	1	EA
C456	CCEA1VH100T	CAP , ELECT	10UF 35V	1	EA
C457	CCEA1VH100T	CAP , ELECT	10UF 35V	1	EA
C458	CCEA1VH100T	CAP , ELECT	10UF 35V	1	EA
C459	CCEA1VH100T	CAP , ELECT	10UF 35V	1	EA

Ref. Designator	Part Number	Description		Qty	
INPUT PCB (CUP11815-1)					
C460	CCEA1VH100T	CAP , ELECT	10UF 35V	1	EA
C522	CCEA1CH101T	CAP , ELECT	100UF 16V	1	EA
C524	CCEA1CH101T	CAP , ELECT	100UF 16V	1	EA
C542	CCEA1HH2R2T	CAP , ELECT	2.2UF 50V	1	EA
C545	CCEA1HH2R2T	CAP , ELECT	2.2UF 50V	1	EA
C554	CCEA1CH101T	CAP , ELECT	100UF 16V	1	EA
C555	CCEA1VH100T	CAP , ELECT	10UF 35V	1	EA
C559	CCEA1VH100T	CAP , ELECT	10UF 35V	1	EA
C561	CCEA1CH101T	CAP , ELECT	100UF 16V	1	EA
C562	CCEA1CH101T	CAP , ELECT	100UF 16V	1	EA
C563	CCEA1CH101T	CAP , ELECT	100UF 16V	1	EA
C578	CCEA1CH101T	CAP , ELECT	100UF 16V	1	EA
C583	CCEA1CH101T	CAP , ELECT	100UF 16V	1	EA
C585	CCEA1HH1R0T	CAP , ELECT	1UF 50V	1	EA
C586	CCEA1HH1R0T	CAP , ELECT	1UF 50V	1	EA
C588	CCEA1CH101T	CAP , ELECT	100UF 16V	1	EA
C589	CCEA1CH101T	CAP , ELECT	100UF 16V	1	EA
C592	CCEA1CH101T	CAP , ELECT	100UF 16V	1	EA
C593	CCEA1CH101T	CAP , ELECT	100UF 16V	1	EA
C594	CCEA1CH101T	CAP , ELECT	100UF 16V	1	EA
C595	CCEA1CH101T	CAP , ELECT	100UF 16V	1	EA
C596	CCEA1EH220T	CAP , ELECT	22UF/25V	1	EA
C597	CCEA1EH220T	CAP , ELECT	22UF/25V	1	EA
C703	CCEA1CH101T	CAP , ELECT	100UF 16V	1	EA
C706	CCEA1CH101T	CAP , ELECT	100UF 16V	1	EA
C717	CCEA1CH101T	CAP , ELECT	100UF 16V	1	EA
C720	CCEA1AH471T	CAP , ELECT	470UF 10V	1	EA
C721	CCEA1AH471T	CAP , ELECT	470UF 10V	1	EA
C724	CCEA1AH471T	CAP , ELECT	470UF 10V	1	EA
C726	CCEA1CH101T	CAP , ELECT	100UF 16V	1	EA
C728	CCEA1AH471T	CAP , ELECT	470UF 10V	1	EA
C730	CCEA1CH101T	CAP , ELECT	100UF 16V	1	EA
C732	CCEA1CH101T	CAP , ELECT	100UF 16V	1	EA
C736	CCEA1HH2R2T	CAP , ELECT	2.2UF 50V	1	EA
C737	CCEA1CH101T	CAP , ELECT	100UF 16V	1	EA
C741	CCEA1CH101T	CAP , ELECT	100UF 16V	1	EA
C746	CCEA1CH101T	CAP , ELECT	100UF 16V	1	EA
C749	CCEA1CH101T	CAP , ELECT	100UF 16V	1	EA
C753	CCEA1CH101T	CAP , ELECT	100UF 16V	1	EA
C755	CCEA1CH101T	CAP , ELECT	100UF 16V	1	EA
C764	CCEA1AH471T	CAP , ELECT	470UF 10V	1	EA
C766	CCEA0JH102T	CAP , ELECT	1000UF 6.3V	1	EA
C237	CCEA1EH470T	CAP , ELECT	47UF 25V	1	EA
C238	CCEA1EH470T	CAP , ELECT	47UF 25V	1	EA
C239	CCEA1VH100T	CAP , ELECT	10UF 35V	1	EA
C240	CCEA1VH100T	CAP , ELECT	10UF 35V	1	EA
C349	CCEA1HH1R0T	CAP , ELECT	1UF 50V	1	EA
Semiconductors					
IC13	HVINJM2068MDTE1	I.C , OP AMP (NJM2068)	JRC	1	EA
IC21	HVITC9163CFG	I.C , FUNCTION SW (TC9163CFG)	TOSHIBA	1	EA
IC22	HVINJM2068MDTE1	I.C , OP AMP (NJM2068)	JRC	1	EA
IC23	HVITC9164CFG	I.C , FUNCTION SW (TC9164CFG)	TOSHIBA	1	EA
IC24	HVITC9163CFG	I.C , FUNCTION SW (TC9163CFG)	TOSHIBA	1	EA
IC25	HVINJM2068MDTE1	I.C , OP AMP (NJM2068)	JRC	1	EA
IC26	HVITC9162CFG	I.C , FUNCTION SW (TC9162CFG)	TOSHIBA	1	EA
IC31	HVINJM2068MDTE1	I.C , OP AMP (NJM2068)	JRC	1	EA
IC32	HVINJM2068MDTE1	I.C , OP AMP (NJM2068)	JRC	1	EA
IC33	HVINJM2068MDTE1	I.C , OP AMP (NJM2068)	JRC	1	EA
IC34	HVINJM2068MDTE1	I.C , OP AMP (NJM2068)	JRC	1	EA

Ref. Designator	Part Number	Description		Qty	
INPUT PCB (CUP11815-1)					
IC35	HVINJM2068MDTE1	I.C , OP AMP (NJM2068)	JRC	1	EA
IC36	HVINJM2068MDTE1	I.C , OP AMP (NJM2068)	JRC	1	EA
IC37	HVINJM2068MDTE1	I.C , OP AMP (NJM2068)	JRC	1	EA
IC42	HVITC9459BFG	I.C , 2CH VOLUME (TC9459BFG)	TOSHIBA	1	EA
IC43	HVITC9482BFG	I.C , 6CH VOLUME (TC9482BFG)	TOSHIBA	1	EA
IC46	HVINJM2068MDTE1	I.C , OP AMP (NJM2068)	JRC	1	EA
IC47	HVINJM2068MDTE1	I.C , OP AMP (NJM2068)	JRC	1	EA
IC48	HVINJM2068MDTE1	I.C , OP AMP (NJM2068)	JRC	1	EA
IC49	HVINJM2068MDTE1	I.C , OP AMP (NJM2068)	JRC	1	EA
IC56	HVITA1270BF	I.C, CRHROMA (TA1270BF)	TOSHIBA	1	EA
IC57	HVITC90A49F	I.C , Y/C SEPERATED (TC90A49F)	TOSHIBA	1	EA
IC58	BVIBH7862FS	IC , 6CH VIDEO DRIVER (BH7862FS)	ROHM	1	EA
IC72	HVI74HCU04AFNG	I.C , INVERTER (74HCU04)	TOSHIBA	1	EA
IC73	HVIK4589VQ-T	I.C , CODEC + DIR (AK4589)	ASAHI KASEI	1	EA
IC74	HVI74LCX32TTR	I.C , OR-GATE (74LCX32)	FAIRCHILD	1	EA
IC75	HVICS49400-CQ	I.C , DECODER (CS49400)	CIRRUS LOGIC	1	EA
IC76	HVIM29W800DT70N340	I.C, 4M FLASH MEMORY (M29W800DT)	ST	1	EA
IC78	HVINJM2391DL133	I.C , CHIP REGULATOR (+3.3V) (NJM2391DL133)	JRC	1	EA
IC79	HVINJM2391DL125	I.C , CHIP REGULATOR (+2.5V) (NJM2391DL125)	JRC	1	EA
Q551	HVTKRC102S	TRANSISTOR , CHIP	KRC102S	1	EA
Q552	HVTKRC102S	TRANSISTOR , CHIP	KRC102S	1	EA
Q553	HVTKTA2014GR	TRANSISTOR, SMD	KTA2014GR	1	EA
Q554	HVTKTC4075GR	TRANSISTOR, SMD	KTC4075GR	1	EA
Q555	HVTKTA2014GR	TRANSISTOR, SMD	KTA2014GR	1	EA
Q556	HVTKTA2014GR	TRANSISTOR, SMD	KTA2014GR	1	EA
D201	HVD1SS133MT	DIODE	1SS133T	1	EA
D202	HVD1SS133MT	DIODE	1SS133T	1	EA
D203	HVD1SS133MT	DIODE	1SS133T	1	EA
D204	HVD1SS133MT	DIODE	1SS133T	1	EA
D205	HVD1SS133MT	DIODE	1SS133T	1	EA
D206	HVD1SS133MT	DIODE	1SS133T	1	EA
D207	HVD1SS133MT	DIODE	1SS133T	1	EA
D208	HVD1SS133MT	DIODE	1SS133T	1	EA
D209	HVD1SS133MT	DIODE	1SS133T	1	EA
D210	HVD1SS133MT	DIODE	1SS133T	1	EA
D211	HVD1SS133MT	DIODE	1SS133T	1	EA
D212	HVD1SS133MT	DIODE	1SS133T	1	EA
D213	HVD1SS133MT	DIODE	1SS133T	1	EA
D214	HVD1SS133MT	DIODE	1SS133T	1	EA
D215	HVD1SS133MT	DIODE	1SS133T	1	EA
D216	HVD1SS133MT	DIODE	1SS133T	1	EA
D701	KVD1N4003ST	DIODE	1N4003	1	EA
Q201	HVTKTC2874BT	TRANSISTOR , MUTE	KTC2874B	1	EA
Q202	HVTKTC2874BT	TRANSISTOR , MUTE	KTC2874B	1	EA
Q203	HVTKTC2874BT	TRANSISTOR , MUTE	KTC2874B	1	EA
Q204	HVTKRA107MT	TRANSISTOR	KRA107M	1	EA
D443	HVDMTZJ6.8BT	DIODE , ZENER	6.8V 1/2W	1	EA
D444	HVDMTZJ6.8BT	DIODE , ZENER	6.8V 1/2W	1	EA
IC55	HVIMC7809C	I.C , REGULATOR (MC7809)	FAIRCHILD	1	EA
IC77	HVI57V161610ET7	SDRAM 16M 7NS (57V161610ET7)	HYNIX	1	EA
<i>Resistors</i>					
RN71	CRJ104DJ101T	RES, ARRAY, 100R (1608)	100 OHM/1608*4	1	EA
RN72	CRJ104DJ101T	RES, ARRAY, 100R (1608)	100 OHM/1608*4	1	EA
RN73	CRJ104DJ101T	RES, ARRAY, 100R (1608)	100 OHM/1608*4	1	EA
RN74	CRJ104DJ101T	RES, ARRAY, 100R (1608)	100 OHM/1608*4	1	EA
RN75	CRJ104DJ101T	RES, ARRAY, 100R (1608)	100 OHM/1608*4	1	EA
RN76	CRJ104DJ101T	RES, ARRAY, 100R (1608)	100 OHM/1608*4	1	EA
RN77	CRJ104DJ101T	RES, ARRAY, 100R (1608)	100 OHM/1608*4	1	EA
RN78	CRJ104DJ101T	RES, ARRAY, 100R (1608)	100 OHM/1608*4	1	EA

Ref. Designator	Part Number	Description		Qty	
INPUT PCB (CUP11815-1)					
RN79	CRJ104DJ101T	RES, ARRAY, 100R (1608)	100 OHM/1608*4	1	EA
RN80	CRJ104DJ330T	RES, 4ARRAY (1608*4)	33 OHM/1608*4	1	EA
RN81	CRJ104DJ330T	RES, 4ARRAY (1608*4)	33 OHM/1608*4	1	EA
RN82	CRJ104DJ330T	RES, 4ARRAY (1608*4)	33 OHM/1608*4	1	EA
RN83	CRJ104DJ330T	RES, 4ARRAY (1608*4)	33 OHM/1608*4	1	EA
RN84	CRJ104DJ332T	RES, ARRAY, 3.3K*4 (1608)	3.3 OHM/1608*4	1	EA
RN86	CRJ104DJ103T	RES, ARRAY, 10K (1608)	10K OHM/1608*4	1	EA
RN87	CRJ104DJ103T	RES, ARRAY, 10K (1608)	10K OHM/1608*4	1	EA
RN88	CRJ104DJ103T	RES, ARRAY, 10K (1608)	10K OHM/1608*4	1	EA
RN89	CRJ104DJ103T	RES, ARRAY, 10K (1608)	10K OHM/1608*4	1	EA
RN90	CRJ104DJ103T	RES, ARRAY, 10K (1608)	10K OHM/1608*4	1	EA
R101	CRJ10DJ562T	RES, CHIP	5.6K OHM	1	EA
R102	CRJ10DJ562T	RES, CHIP	5.6K OHM	1	EA
R103	CRJ10DJ682T	RES, CHIP	6.8K OHM	1	EA
R104	CRJ10DJ682T	RES, CHIP	6.8K OHM	1	EA
R105	CRJ10DJ151T	RES, CHIP	150 OHM	1	EA
R106	CRJ10DJ151T	RES, CHIP	150 OHM	1	EA
R107	CRJ10DJ101T	RES, CHIP	100 OHM	1	EA
R108	CRJ10DJ101T	RES, CHIP	100 OHM	1	EA
R201	CRJ10DJ471T	RES, CHIP	470 OHM	1	EA
R202	CRJ10DJ471T	RES, CHIP	470 OHM	1	EA
R203	CRJ10DJ471T	RES, CHIP	470 OHM	1	EA
R204	CRJ10DJ471T	RES, CHIP	470 OHM	1	EA
R205	CRJ10DJ471T	RES, CHIP	470 OHM	1	EA
R206	CRJ10DJ471T	RES, CHIP	470 OHM	1	EA
R207	CRJ10DJ471T	RES, CHIP	470 OHM	1	EA
R208	CRJ10DJ471T	RES, CHIP	470 OHM	1	EA
R209	CRJ10DJ471T	RES, CHIP	470 OHM	1	EA
R210	CRJ10DJ471T	RES, CHIP	470 OHM	1	EA
R211	CRJ10DJ471T	RES, CHIP	470 OHM	1	EA
R212	CRJ10DJ471T	RES, CHIP	470 OHM	1	EA
R213	CRJ10DJ471T	RES, CHIP	470 OHM	1	EA
R214	CRJ10DJ471T	RES, CHIP	470 OHM	1	EA
R215	CRJ10DJ471T	RES, CHIP	470 OHM	1	EA
R216	CRJ10DJ471T	RES, CHIP	470 OHM	1	EA
R217	CRJ10DJ471T	RES, CHIP	470 OHM	1	EA
R218	CRJ10DJ471T	RES, CHIP	470 OHM	1	EA
R219	CRJ10DJ471T	RES, CHIP	470 OHM	1	EA
R220	CRJ10DJ471T	RES, CHIP	470 OHM	1	EA
R221	CRJ10DJ471T	RES, CHIP	470 OHM	1	EA
R222	CRJ10DJ471T	RES, CHIP	470 OHM	1	EA
R223	CRJ10DJ471T	RES, CHIP	470 OHM	1	EA
R224	CRJ10DJ272T	RES, CHIP	2.7K OHM	1	EA
R225	CRJ10DJ471T	RES, CHIP	470 OHM	1	EA
R226	CRJ10DJ471T	RES, CHIP	470 OHM	1	EA
R227	CRJ10DJ474T	RES, CHIP	470K OHM	1	EA
R228	CRJ10DJ474T	RES, CHIP	470K OHM	1	EA
R229	CRJ10DJ474T	RES, CHIP	470K OHM	1	EA
R230	CRJ10DJ474T	RES, CHIP	470K OHM	1	EA
R231	CRJ10DJ474T	RES, CHIP	470K OHM	1	EA
R232	CRJ10DJ474T	RES, CHIP	470K OHM	1	EA
R233	CRJ10DJ474T	RES, CHIP	470K OHM	1	EA
R234	CRJ10DJ474T	RES, CHIP	470K OHM	1	EA
R235	CRJ10DJ474T	RES, CHIP	470K OHM	1	EA
R236	CRJ10DJ474T	RES, CHIP	470K OHM	1	EA
R237	CRJ10DJ474T	RES, CHIP	470K OHM	1	EA
R238	CRJ10DJ474T	RES, CHIP	470K OHM	1	EA
R239	CRJ10DJ474T	RES, CHIP	470K OHM	1	EA
R240	CRJ10DJ474T	RES, CHIP	470K OHM	1	EA
R241	CRJ10DJ474T	RES, CHIP	470K OHM	1	EA
R242	CRJ10DJ474T	RES, CHIP	470K OHM	1	EA

Ref. Designator	Part Number	Description		Qty	
INPUT PCB (CUP11815-1)					
R243	CRJ10DJ474T	RES, CHIP	470K OHM	1	EA
R244	CRJ10DJ474T	RES, CHIP	470K OHM	1	EA
R245	CRJ10DJ474T	RES, CHIP	470K OHM	1	EA
R246	CRJ10DJ474T	RES, CHIP	470K OHM	1	EA
R247	CRJ10DJ474T	RES, CHIP	470K OHM	1	EA
R248	CRJ10DJ474T	RES, CHIP	470K OHM	1	EA
R249	CRJ10DJ474T	RES, CHIP	470K OHM	1	EA
R250	CRJ10DJ103T	RES, CHIP	10K OHM	1	EA
R251	CRJ10DJ474T	RES, CHIP	470K OHM	1	EA
R252	CRJ10DJ474T	RES, CHIP	470K OHM	1	EA
R255	CRJ10DJ471T	RES, CHIP	470 OHM	1	EA
R256	CRJ10DJ471T	RES, CHIP	470 OHM	1	EA
R257	CRJ10DJ472T	RES, CHIP	4.7K OHM	1	EA
R258	CRJ10DJ472T	RES, CHIP	4.7K OHM	1	EA
R259	CRJ10DJ472T	RES, CHIP	4.7K OHM	1	EA
R261	CRJ10DJ104T	RES, CHIP	100K OHM	1	EA
R262	CRJ10DJ104T	RES, CHIP	100K OHM	1	EA
R263	CRJ10DJ101T	RES, CHIP	100 OHM	1	EA
R264	CRJ10DJ101T	RES, CHIP	100 OHM	1	EA
R265	CRJ10DJ471T	RES, CHIP	470 OHM	1	EA
R267	CRJ10DJ471T	RES, CHIP	470 OHM	1	EA
R268	CRJ10DJ184T	RES, CHIP	180K OHM	1	EA
R269	CRJ10DJ184T	RES, CHIP	180K OHM	1	EA
R270	CRJ10DJ472T	RES, CHIP	4.7K OHM	1	EA
R271	CRJ10DJ472T	RES, CHIP	4.7K OHM	1	EA
R272	CRJ10DJ472T	RES, CHIP	4.7K OHM	1	EA
R273	CRJ10DJ471T	RES, CHIP	470 OHM	1	EA
R274	CRJ10DJ471T	RES, CHIP	470 OHM	1	EA
R275	CRJ10DJ472T	RES, CHIP	4.7K OHM	1	EA
R276	CRJ10DJ472T	RES, CHIP	4.7K OHM	1	EA
R277	CRJ10DJ472T	RES, CHIP	4.7K OHM	1	EA
R278	CRJ10DJ104T	RES, CHIP	100K OHM	1	EA
R279	CRJ10DJ104T	RES, CHIP	100K OHM	1	EA
R283	CRJ10DJ331T	RES, CHIP	330 OHM	1	EA
R284	CRJ10DJ331T	RES, CHIP	330 OHM	1	EA
R285	CRJ10DJ184T	RES, CHIP	180K OHM	1	EA
R286	CRJ10DJ184T	RES, CHIP	180K OHM	1	EA
R287	CRJ10DJ184T	RES, CHIP	180K OHM	1	EA
R288	CRJ10DJ184T	RES, CHIP	180K OHM	1	EA
R289	CRJ10DJ184T	RES, CHIP	180K OHM	1	EA
R290	CRJ10DJ184T	RES, CHIP	180K OHM	1	EA
R291	CRJ10DJ472T	RES, CHIP	4.7K OHM	1	EA
R292	CRJ10DJ472T	RES, CHIP	4.7K OHM	1	EA
R293	CRJ10DJ472T	RES, CHIP	4.7K OHM	1	EA
R301	CRJ10DJ332T	RES, CHIP	3.3K OHM	1	EA
R302	CRJ10DJ332T	RES, CHIP	3.3K OHM	1	EA
R303	CRJ10DJ332T	RES, CHIP	3.3K OHM	1	EA
R304	CRJ10DJ332T	RES, CHIP	3.3K OHM	1	EA
R305	CRJ10DJ332T	RES, CHIP	3.3K OHM	1	EA
R306	CRJ10DJ332T	RES, CHIP	3.3K OHM	1	EA
R307	CRJ10DJ332T	RES, CHIP	3.3K OHM	1	EA
R308	CRJ10DJ332T	RES, CHIP	3.3K OHM	1	EA
R309	CRJ10DJ332T	RES, CHIP	3.3K OHM	1	EA
R310	CRJ10DJ332T	RES, CHIP	3.3K OHM	1	EA
R311	CRJ10DJ332T	RES, CHIP	3.3K OHM	1	EA
R312	CRJ10DJ332T	RES, CHIP	3.3K OHM	1	EA
R313	CRJ10DJ332T	RES, CHIP	3.3K OHM	1	EA
R314	CRJ10DJ332T	RES, CHIP	3.3K OHM	1	EA
R315	CRJ10DJ332T	RES, CHIP	3.3K OHM	1	EA
R316	CRJ10DJ332T	RES, CHIP	3.3K OHM	1	EA
R317	CRJ10DJ101T	RES, CHIP	100 OHM	1	EA

Ref. Designator	Part Number	Description		Qty	
INPUT PCB (CUP11815-1)					
R318	CRJ10DJ101T	RES , CHIP	100 OHM	1	EA
R319	CRJ10DJ101T	RES , CHIP	100 OHM	1	EA
R320	CRJ10DJ101T	RES , CHIP	100 OHM	1	EA
R321	CRJ10DJ512T	RES , CHIP	5.1K OHM	1	EA
R322	CRJ10DJ122T	RES , CHIP	1.2K OHM	1	EA
R323	CRJ10DJ122T	RES , CHIP	1.2K OHM	1	EA
R324	CRJ10DJ512T	RES , CHIP	5.1K OHM	1	EA
R325	CRJ10DJ512T	RES , CHIP	5.1K OHM	1	EA
R326	CRJ10DJ122T	RES , CHIP	1.2K OHM	1	EA
R327	CRJ10DJ122T	RES , CHIP	1.2K OHM	1	EA
R328	CRJ10DJ123T	RES , CHIP	12K OHM	1	EA
R329	CRJ10DJ512T	RES , CHIP	5.1K OHM	1	EA
R330	CRJ10DJ122T	RES , CHIP	1.2K OHM	1	EA
R331	CRJ10DJ122T	RES , CHIP	1.2K OHM	1	EA
R332	CRJ10DJ512T	RES , CHIP	5.1K OHM	1	EA
R333	CRJ10DJ512T	RES , CHIP	5.1K OHM	1	EA
R334	CRJ10DJ122T	RES , CHIP	1.2K OHM	1	EA
R335	CRJ10DJ122T	RES , CHIP	1.2K OHM	1	EA
R336	CRJ10DJ512T	RES , CHIP	5.1K OHM	1	EA
R337	CRJ10DJ101T	RES , CHIP	100 OHM	1	EA
R338	CRJ10DJ101T	RES , CHIP	100 OHM	1	EA
R339	CRJ10DJ101T	RES , CHIP	100 OHM	1	EA
R340	CRJ10DJ101T	RES , CHIP	100 OHM	1	EA
R341	CRJ10DJ122T	RES , CHIP	1.2K OHM	1	EA
R344	CRJ10DJ122T	RES , CHIP	1.2K OHM	1	EA
R345	CRJ10DJ122T	RES , CHIP	1.2K OHM	1	EA
R348	CRJ10DJ122T	RES , CHIP	1.2K OHM	1	EA
R349	CRJ10DJ122T	RES , CHIP	1.2K OHM	1	EA
R352	CRJ10DJ122T	RES , CHIP	1.2K OHM	1	EA
R353	CRJ10DJ122T	RES , CHIP	1.2K OHM	1	EA
R356	CRJ10DJ122T	RES , CHIP	1.2K OHM	1	EA
R361	CRJ10DJ104T	RES , CHIP	100K OHM	1	EA
R362	CRJ10DJ104T	RES , CHIP	100K OHM	1	EA
R363	CRJ10DJ104T	RES , CHIP	100K OHM	1	EA
R364	CRJ10DJ104T	RES , CHIP	100K OHM	1	EA
R365	CRJ10DJ104T	RES , CHIP	100K OHM	1	EA
R366	CRJ10DJ104T	RES , CHIP	100K OHM	1	EA
R367	CRJ10DJ104T	RES , CHIP	100K OHM	1	EA
R368	CRJ10DJ104T	RES , CHIP	100K OHM	1	EA
R371	CRJ10DJ332T	RES , CHIP	3.3K OHM	1	EA
R372	CRJ10DJ332T	RES , CHIP	3.3K OHM	1	EA
R373	CRJ10DJ332T	RES , CHIP	3.3K OHM	1	EA
R374	CRJ10DJ332T	RES , CHIP	3.3K OHM	1	EA
R375	CRJ10DJ332T	RES , CHIP	3.3K OHM	1	EA
R376	CRJ10DJ332T	RES , CHIP	3.3K OHM	1	EA
R377	CRJ10DJ332T	RES , CHIP	3.3K OHM	1	EA
R378	CRJ10DJ332T	RES , CHIP	3.3K OHM	1	EA
R379	CRJ10DJ332T	RES , CHIP	3.3K OHM	1	EA
R380	CRJ10DJ332T	RES , CHIP	3.3K OHM	1	EA
R381	CRJ10DJ101T	RES , CHIP	100 OHM	1	EA
R382	CRJ10DJ101T	RES , CHIP	100 OHM	1	EA
R383	CRJ10DJ101T	RES , CHIP	100 OHM	1	EA
R384	CRJ10DJ101T	RES , CHIP	100 OHM	1	EA
R385	CRJ10DJ101T	RES , CHIP	100 OHM	1	EA
R386	CRJ10DJ101T	RES , CHIP	100 OHM	1	EA
R389	CRJ10DJ332T	RES , CHIP	3.3K OHM	1	EA
R390	CRJ10DJ332T	RES , CHIP	3.3K OHM	1	EA
R391	CRJ10DJ105T	RES , CHIP	1M OHM	1	EA
R392	CRJ10DJ105T	RES , CHIP	1M OHM	1	EA
R393	CRJ10DJ332T	RES , CHIP	3.3K OHM	1	EA
R394	CRJ10DJ153T	RES , CHIP	15K OHM	1	EA

Ref. Designator	Part Number	Description		Qty	
INPUT PCB (CUP11815-1)					
R395	CRJ10DJ153T	RES , CHIP	15K OHM	1	EA
R396	CRJ10DJ332T	RES , CHIP	3.3K OHM	1	EA
R397	CRJ10DJ101T	RES , CHIP	100 OHM	1	EA
R398	CRJ10DJ101T	RES , CHIP	100 OHM	1	EA
R403	CRJ10DJ184T	RES , CHIP	180K OHM	1	EA
R404	CRJ10DJ184T	RES , CHIP	180K OHM	1	EA
R405	CRJ10DJ184T	RES , CHIP	180K OHM	1	EA
R406	CRJ10DJ184T	RES , CHIP	180K OHM	1	EA
R407	CRJ10DJ184T	RES , CHIP	180K OHM	1	EA
R408	CRJ10DJ184T	RES , CHIP	180K OHM	1	EA
R409	CRJ10DJ184T	RES , CHIP	180K OHM	1	EA
R410	CRJ10DJ184T	RES , CHIP	180K OHM	1	EA
R413	CRJ10DJ512T	RES , CHIP	5.1K OHM	1	EA
R414	CRJ10DJ512T	RES , CHIP	5.1K OHM	1	EA
R415	CRJ10DJ512T	RES , CHIP	5.1K OHM	1	EA
R416	CRJ10DJ912T	RES,CHIP(1/10W) 9.1K OHM J	9.1K OHM	1	EA
R417	CRJ10DJ512T	RES , CHIP	5.1K OHM	1	EA
R418	CRJ10DJ512T	RES , CHIP	5.1K OHM	1	EA
R419	CRJ10DJ512T	RES , CHIP	5.1K OHM	1	EA
R420	CRJ10DJ512T	RES , CHIP	5.1K OHM	1	EA
R423	CRJ10DJ102T	RES , CHIP	1K OHM	1	EA
R424	CRJ10DJ102T	RES , CHIP	1K OHM	1	EA
R425	CRJ10DJ102T	RES , CHIP	1K OHM	1	EA
R426	CRJ10DJ102T	RES , CHIP	1K OHM	1	EA
R427	CRJ10DJ102T	RES , CHIP	1K OHM	1	EA
R428	CRJ10DJ102T	RES , CHIP	1K OHM	1	EA
R429	CRJ10DJ102T	RES , CHIP	1K OHM	1	EA
R430	CRJ10DJ102T	RES , CHIP	1K OHM	1	EA
R433	CRJ10DJ101T	RES , CHIP	100 OHM	1	EA
R434	CRJ10DJ101T	RES , CHIP	100 OHM	1	EA
R435	CRJ10DJ101T	RES , CHIP	100 OHM	1	EA
R436	CRJ10DJ101T	RES , CHIP	100 OHM	1	EA
R437	CRJ10DJ101T	RES , CHIP	100 OHM	1	EA
R438	CRJ10DJ101T	RES , CHIP	100 OHM	1	EA
R439	CRJ10DJ101T	RES , CHIP	100 OHM	1	EA
R440	CRJ10DJ101T	RES , CHIP	100 OHM	1	EA
R453	CRJ10DJ184T	RES , CHIP	180K OHM	1	EA
R454	CRJ10DJ184T	RES , CHIP	180K OHM	1	EA
R455	CRJ10DJ184T	RES , CHIP	180K OHM	1	EA
R456	CRJ10DJ184T	RES , CHIP	180K OHM	1	EA
R457	CRJ10DJ184T	RES , CHIP	180K OHM	1	EA
R458	CRJ10DJ184T	RES , CHIP	180K OHM	1	EA
R459	CRJ10DJ184T	RES , CHIP	180K OHM	1	EA
R460	CRJ10DJ184T	RES , CHIP	180K OHM	1	EA
R471	CRJ10DJ272T	RES , CHIP	2.7K OHM	1	EA
R472	CRJ10DJ272T	RES , CHIP	2.7K OHM	1	EA
R473	CRJ10DJ272T	RES , CHIP	2.7K OHM	1	EA
R474	CRJ10DJ272T	RES , CHIP	2.7K OHM	1	EA
R481	CRJ10DJ512T	RES , CHIP	5.1K OHM	1	EA
R482	CRJ10DJ512T	RES , CHIP	5.1K OHM	1	EA
R483	CRJ10DJ512T	RES , CHIP	5.1K OHM	1	EA
R484	CRJ10DJ123T	RES , CHIP	12K OHM	1	EA
R485	CRJ10DJ512T	RES , CHIP	5.1K OHM	1	EA
R486	CRJ10DJ512T	RES , CHIP	5.1K OHM	1	EA
R487	CRJ10DJ512T	RES , CHIP	5.1K OHM	1	EA
R488	CRJ10DJ512T	RES , CHIP	5.1K OHM	1	EA
R491	CRJ10DJ4R7T	RES , CHIP	4.7 OHM	1	EA
R492	CRJ10DJ4R7T	RES , CHIP	4.7 OHM	1	EA
R493	CRJ10DJ4R7T	RES , CHIP	4.7 OHM	1	EA
R494	CRJ10DJ4R7T	RES , CHIP	4.7 OHM	1	EA
R495	CRJ10DJ4R7T	RES , CHIP	4.7 OHM	1	EA

Ref. Designator	Part Number	Description		Qty	
INPUT PCB (CUP11815-1)					
R496	CRJ10DJ4R7T	RES , CHIP	4.7 OHM	1	EA
R497	CRJ10DJ4R7T	RES , CHIP	4.7 OHM	1	EA
R498	CRJ10DJ4R7T	RES , CHIP	4.7 OHM	1	EA
R551	CRJ10DJ102T	RES , CHIP	1K OHM	1	EA
R552	CRJ10DJ102T	RES , CHIP	1K OHM	1	EA
R553	CRJ10DJ102T	RES , CHIP	1K OHM	1	EA
R554	CRJ10DJ102T	RES , CHIP	1K OHM	1	EA
R556	CRJ10DJ153T	RES , CHIP	15K OHM	1	EA
R557	CRJ10DJ182T	RES , CHIP	1.8K OHM	1	EA
R558	CRJ10DJ241T	RES , CHIP	240 OHM	1	EA
R561	CRJ10DJ333T	RES , CHIP	33K OHM	1	EA
R562	CRJ10DJ332T	RES , CHIP	3.3K OHM	1	EA
R563	CRJ10DJ331T	RES , CHIP	330 OHM	1	EA
R564	CRJ10DJ101T	RES , CHIP	100 OHM	1	EA
R565	CRJ10DJ101T	RES , CHIP	100 OHM	1	EA
R567	CRJ10DJ101T	RES , CHIP	100 OHM	1	EA
R568	CRJ10DJ101T	RES , CHIP	100 OHM	1	EA
R569	CRJ10DJ821T	RES , CHIP	820 OHM	1	EA
R571	CRJ10DJ433T	RES , CHIP	43K OHM	1	EA
R572	CRJ10DJ222T	RES , CHIP	2.2K OHM	1	EA
R573	CRJ10DJ561T	RES , CHIP	560 OHM	1	EA
R574	CRJ10DJ102T	RES , CHIP	1K OHM	1	EA
R575	CRJ10DJ222T	RES , CHIP	2.2K OHM	1	EA
R581	CRJ10DJ100T	RES , CHIP	10 OHM	1	EA
R582	CRJ10DJ820T	RES , CHIP	82 OHM	1	EA
R583	CRJ10DJ620T	RES , CHIP	62 OHM	1	EA
R584	CRJ10DJ680T	RES , CHIP	68 OHM	1	EA
R585	CRJ10DJ750T	RES , CHIP	75 OHM	1	EA
R586	CRJ10DJ820T	RES , CHIP	82 OHM	1	EA
R587	CRJ10DJ910T	RES , CHIP	91 OHM	1	EA
R588	CRJ10DJ750T	RES , CHIP	75 OHM	1	EA
R590	CRJ10DJ222T	RES , CHIP	2.2K OHM	1	EA
R591	CRJ10DJ222T	RES , CHIP	2.2K OHM	1	EA
R701	CRJ10DJ0R0T	RES , CHIP	0 OHM	1	EA
R702	CRJ10DJ101T	RES , CHIP	100 OHM	1	EA
R703	CRJ10DJ101T	RES , CHIP	100 OHM	1	EA
R704	CRJ10DJ101T	RES , CHIP	100 OHM	1	EA
R705	CRJ10DJ102T	RES , CHIP	1K OHM	1	EA
R707	CRJ10DJ101T	RES , CHIP	100 OHM	1	EA
R714	CRJ10DJ104T	RES , CHIP	100K OHM	1	EA
R715	CRJ10DJ104T	RES , CHIP	100K OHM	1	EA
R716	CRJ10DJ472T	RES , CHIP	4.7K OHM	1	EA
R717	CRJ10DJ3R3T	CHIP RES	3.3 OHM	1	EA
R718	CRJ10DJ123T	RES , CHIP	12K OHM	1	EA
R719	CRJ10DJ473T	RES , CHIP	47K OHM	1	EA
R720	CRJ10DJ473T	RES , CHIP	47K OHM	1	EA
R721	CRJ10DJ330T	RES , CHIP	33 OHM	1	EA
R723	CRJ10DJ2R7T	RES , CHIP	2.7 OHM	1	EA
R724	CRJ10DJ101T	RES , CHIP	100 OHM	1	EA
R725	CRJ10DJ473T	RES , CHIP	47K OHM	1	EA
R726	CRJ10DJ473T	RES , CHIP	47K OHM	1	EA
R727	CRJ10DJ473T	RES , CHIP	47K OHM	1	EA
R728	CRJ10DJ330T	RES , CHIP	33 OHM	1	EA
R759	CRJ10DJ181T	RES , CHIP	180 OHM	1	EA
R760	CRJ10DJ105T	RES , CHIP	1M OHM	1	EA
R765	CRJ10DJ103T	RES , CHIP	10K OHM	1	EA
R766	CRJ10DJ103T	RES , CHIP	10K OHM	1	EA
R767	CRJ10DJ152T	RES , CHIP	1.5K OHM	1	EA
R768	CRJ10DJ152T	RES , CHIP	1.5K OHM	1	EA
R769	CRJ10DJ103T	RES , CHIP	10K OHM	1	EA
R770	CRJ10DJ103T	RES , CHIP	10K OHM	1	EA

Ref. Designator	Part Number	Description		Qty	
INPUT PCB (CUP11815-1)					
R771	CRJ10DJ330T	RES , CHIP	33 OHM	1	EA
R772	CRJ10DJ330T	RES , CHIP	33 OHM	1	EA
R773	CRJ10DJ103T	RES , CHIP	10K OHM	1	EA
R774	CRJ10DJ330T	RES , CHIP	33 OHM	1	EA
R775	CRJ10DJ103T	RES , CHIP	10K OHM	1	EA
R776	CRJ10DJ332T	RES , CHIP	3.3K OHM	1	EA
R777	CRJ10DJ102T	RES , CHIP	1K OHM	1	EA
R778	CRJ10DJ103T	RES , CHIP	10K OHM	1	EA
R779	CRJ10DJ103T	RES , CHIP	10K OHM	1	EA
R786	CRJ10DJ103T	RES , CHIP	10K OHM	1	EA
R787	CRJ10DJ332T	RES , CHIP	3.3K OHM	1	EA
R788	CRJ10DJ332T	RES , CHIP	3.3K OHM	1	EA
R801	CRJ10DJ103T	RES , CHIP	10K OHM	1	EA
R802	CRJ10DJ103T	RES , CHIP	10K OHM	1	EA
R803	CRJ10DJ330T	RES , CHIP	33 OHM	1	EA
R804	CRJ10DJ103T	RES , CHIP	10K OHM	1	EA
R809	CRJ10DJ330T	RES , CHIP	33 OHM	1	EA
R810	CRJ10DJ330T	RES , CHIP	33 OHM	1	EA
R814	CRJ10DJ101T	RES , CHIP	100 OHM	1	EA
R815	CRJ10DJ103T	RES , CHIP	10K OHM	1	EA
R817	CRJ10DJ103T	RES , CHIP	10K OHM	1	EA
R822	CRJ10DJ220T	RES , CHIP	22 OHM	1	EA
R823	CRJ10DJ101T	RES , CHIP	100 OHM	1	EA
R824	CRJ10DJ330T	RES , CHIP	33 OHM	1	EA
R589	CRQ2AJ6R8H	RES , FUSE	6.8 OHM 2W J	1	EA
R780	CRG2ANJ330H	RES , METAL OXIDE FILM	33 OHM 2W J	1	EA
R781	CRG2ANJ330H	RES , METAL OXIDE FILM	33 OHM 2W J	1	EA
R782	CRG2ANJ330H	RES , METAL OXIDE FILM	33 OHM 2W J	1	EA
<i>Miscellaneous</i>					
L701	HLZ9Z014Z	CHIP , BEAD	HU-1H4516-600JT	1	EA
L702	HLZ9Z014Z	CHIP , BEAD	HU-1H4516-600JT	1	EA
L703	HLZ9Z014Z	CHIP , BEAD	HU-1H4516-600JT	1	EA
L704	HLZ9Z014Z	CHIP , BEAD	HU-1H4516-600JT	1	EA
L550	HLQ02C220KT	COIL , AXAIL	22UH	1	EA
L551	HLQ02C100KT	COIL , AXAIL	10UH	1	EA
L552	HLQ02C100KT	COIL , AXAIL	10UH	1	EA
L553	HLQ02C100KT	COIL , AXAIL	10UH	1	EA
L554	HLQ02C100KT	COIL , AXAIL	10UH	1	EA
L562	HLQ02CR68KT	COIL , AXAIL	0.68UH	1	EA
BN11	KJP08GB99ZM	CONNECTOR , HOUSING	CONNECTOR	1	EA
BN12	KJP15GB99ZM	WAFER	WAFER	1	EA
BN14	CWB2B006100EN	WIRE ASS'Y	WIRE	1	EA
BN42	CWZAVR140BN42	WIRE ASS'Y	WIRE	1	EA
BN43	CWZAVR340BN43	WIRE ASS'Y	WIRE	1	EA
BN52	CWB2B905150EN	WIRE , ASS'Y	WIRE	1	EA
CN10	CJP04GB46ZY	WAFER	WAFER	1	EA
CN13	CJP13GA115ZY	WAFER , CARD CABLE	WAFER	1	EA
CN15	CJP13GA115ZY	WAFER , CARD CABLE	WAFER	1	EA
CN16	CJP10GA115ZY	WAFER , CARD CABLE	WAFER	1	EA
CN17	KJP12GB142ZP	PIN HEADER	PIN HEADER	1	EA
CN18	CJP05GA19ZY	WAFER , STRAIGHT, 5PIN	WAFER	1	EA
CN19	CJP03GA19ZY	WAFER , STRAIGHT, 3PIN	WAFER	1	EA
CN61	CJP10GA19ZY	WAFER , STRAIGHT, 10PIN	WAFER	1	EA
CN72	KJP32GA117ZG	WAFER , CARD CABLE	WAFER	1	EA
CN97	CJP02GA19ZY	WAFER , 2PIN	WAFER	1	EA
ET02	CMD1A569	BRACKET , PCB	BRACKET	1	EA
JK11	CJJ4R019W	TERMINAL , IN/OUT	TERMINAL JACK	1	EA
JK12	CJJ4P014W	JACK , IN/OUT	JACK	1	EA
JK13	CJJ4P014W	JACK , IN/OUT	JACK	1	EA

Ref. Designator	Part Number	Description		Qty	
INPUT PCB (CUP11815-1)					
JK14	CJJ4R019W	TERMINAL , IN/OUT	TERMINAL JACK	1	EA
JK15	CJJ4R037W	JACK , BOARD	JACK	1	EA
JW21	CWE7202090AA	WIRE ASS'Y	WIRE	1	EA
L561	HLQ02CR68KT	COIL , AXAIL	0.68UH	1	EA
L563	HLQ02CR39KT	COIL , AXAIL	0.39UH	1	EA
X561	H2OX03579D140TF	CRYSTAL	3.579MHZ	1	EA
X563	HVFC5BLA503KECZ	CERAMINC, RESONATOR	RESONATOR	1	EA
X701	HOX12288E220CS	CRYSTAL	12.288MHZ 22PF	1	EA
MUTI-ROOM & A-BUS PCB (CUP11815-2)					
<i>Capacitors</i>					
C401	CCEA1VH100T	CAP , ELECT	10UF 35V	1	EA
C402	CCEA1VH100T	CAP , ELECT	10UF 35V	1	EA
C411	HCUS1H223KC	CAP , CHIP	2200PF	1	EA
C412	HCUS1H223KC	CAP , CHIP	2200PF	1	EA
C423	HCUS1H151JA	CAP , CHIP , 150PFJA	150PF	1	EA
C424	HCUS1H151JA	CAP , CHIP , 150PFJA	150PF	1	EA
C431	CCEA1CH101T	CAP , ELECT	100UF 16V	1	EA
C432	CCEA1CH101T	CAP , ELECT	100UF 16V	1	EA
C443	CCEA1VH100T	CAP , ELECT	10UF 35V	1	EA
C444	CCEA1VH100T	CAP , ELECT	10UF 35V	1	EA
C445	CCEA1CH101T	CAP , ELECT	100UF 16V	1	EA
C446	CCEA1CH101T	CAP , ELECT	100UF 16V	1	EA
C447	CCEA1VH100T	CAP , ELECT	10UF 35V	1	EA
C448	HCUS1H331JA	CAP , CHIP	330PF	1	EA
C450	CCEA1VH331T	CAP , ELECT	330UF 35V	1	EA
C451	CCEA1VH100T	CAP , ELECT	10UF 35V	1	EA
C452	CCEA1VH100T	CAP , ELECT	10UF 35V	1	EA
C467	HCUS1C105ZF	CAP , CHIP	1UF	1	EA
C468	HCUS1C105ZF	CAP , CHIP	1UF	1	EA
C469	HCUS1C105ZF	CAP , CHIP	1UF	1	EA
C470	HCUS1C105ZF	CAP , CHIP	1UF	1	EA
C475	HCUS1H104ZF	CAP , CHIP	0.1UF	1	EA
C476	HCUS1H101JA	CAP , CHIP	100PF	1	EA
C477	HCUS1H101JA	CAP , CHIP	100PF	1	EA
C478	HCUS1C105ZF	CAP , CHIP	1UF	1	EA
C479	HCUS1C105ZF	CAP , CHIP	1UF	1	EA
C480	CCKT1H103ZF	CAP , CERAMIC	0.01UF 50V ZF	1	EA
<i>Semiconductors</i>					
D445	HVDMTZJ6.8BT	DIODE , ZENER	6.8V 1/2W	1	EA
D446	HVDMTZJ6.8BT	DIODE , ZENER	6.8V 1/2W	1	EA
D447	HVDMTZJ12BT	DIODE , ZENER	12V 1/2W	1	EA
D475	HVD1SS133MT	DIODE	1SS133T	1	EA
IC44	HVINJW1159M	I.C , VOLUME (2-CH) (NJW1159M)	JRC	1	EA
IC45	HVINJM2068MDTE1	I.C , OP AMP (NJM2068)	JRC	1	EA
IC50	HVINJM2068MDTE1	I.C , OP AMP (NJM2068)	JRC	1	EA
Q451	HVTKTC2874BT	TRANSISTOR, MUTE	KTC2874B	1	EA
Q452	HVTKTC2874BT	TRANSISTOR, MUTE	KTC2874B	1	EA
Q453	HVTKTC2874BT	TRANSISTOR, MUTE	KTC2874B	1	EA
Q454	HVTKTC2874BT	TRANSISTOR, MUTE	KTC2874B	1	EA
<i>Resistors</i>					
R401	CRJ10DJ184T	RES , CHIP	180K OHM	1	EA
R402	CRJ10DJ184T	RES , CHIP	180K OHM	1	EA
R421	CRJ10DJ562T	RES , CHIP	5.6K OHM	1	EA
R422	CRJ10DJ562T	RES , CHIP	5.6K OHM	1	EA

Ref. Designator	Part Number	Description		Qty	
MUTI-ROOM & A-BUS PCB (CUP11815-2)					
R431	CRJ10DJ122T	RES , CHIP	1.2K OHM	1	EA
R432	CRJ10DJ122T	RES , CHIP	1.2K OHM	1	EA
R441	CRJ10DJ101T	RES , CHIP	100 OHM	1	EA
R442	CRJ10DJ101T	RES , CHIP	100 OHM	1	EA
R445	CRJ10DJ821T	RES, CHIP	820 OHM	1	EA
R446	CRJ10DJ821T	RES, CHIP	820 OHM	1	EA
R447	CRD20TJ472T	RES , CARBON	4.7K OHM 1/5W J	1	EA
R451	CRJ10DJ184T	RES , CHIP	180K OHM	1	EA
R452	CRJ10DJ184T	RES , CHIP	180K OHM	1	EA
R461	CRJ10DJ104T	RES , CHIP	100K OHM	1	EA
R462	CRJ10DJ104T	RES , CHIP	100K OHM	1	EA
R463	CRJ10DJ821T	RES, CHIP	820 OHM	1	EA
R464	CRJ10DJ821T	RES, CHIP	820 OHM	1	EA
R465	CRJ10DJ472T	RES , CHIP	4.7K OHM	1	EA
R466	CRJ10DJ472T	RES , CHIP	4.7K OHM	1	EA
R467	CRJ10DJ472T	RES , CHIP	4.7K OHM	1	EA
R468	CRJ10DJ472T	RES , CHIP	4.7K OHM	1	EA
R469	CRJ10DJ184T	RES , CHIP	180K OHM	1	EA
R470	CRJ10DJ184T	RES , CHIP	180K OHM	1	EA
R475	CRJ10DJ4R7T	RES , CHIP	4.7 OHM	1	EA
R476	CRJ10DJ221T	RES , CHIP	220 OHM	1	EA
R477	CRJ10DJ221T	RES , CHIP	220 OHM	1	EA
R478	CRJ10DJ562T	RES , CHIP	5.6K OHM	1	EA
R479	CRJ10DJ562T	RES , CHIP	5.6K OHM	1	EA
R480	CRJ10DJ102T	RES , CHIP	1K OHM	1	EA
R489	CRJ10DJ392T	RES . CHIP	3.9K OHM	1	EA
R490	CRJ10DJ392T	RES . CHIP	3.9K OHM	1	EA
R499	CRJ10DJ102T	RES , CHIP	1K OHM	1	EA
<i>Miscellaneous</i>					
CN12	CJP03GA19ZY	WAFER, STRAIGHT, 3PIN	WAFER	1	EA
JK16	CJJ4N076Z	JACK , IN/OUT	JACK	1	EA
JK17	CJJ9L004Z	JACK , RJ-45	JACK	1	EA
JK18	CJJ2D008Z	JACK , STEREO	JACK	1	EA
BN16	CJP10GA115ZY	WAFER , CARD CABLE	WAFER	1	EA
BN29	CWZAVR340BN11	WIRE ASS'Y (SHIELD)	WIRE	1	EA
BN87	CWB1C902050EN	WIRE ASS'Y	WIRE	1	EA
BN90	CWB1C902300EN	WIRE	WIRE	1	EA
VIDEO PCB (CUP11849-1)					
<i>Capacitors</i>					
C401	CCEA1VH100T	CAP , ELECT	10UF 35V	1	EA
C402	CCKT1H101KB	CAP , CERAMIC	100PF 50V KB	1	EA
C403	CCEA1VH100T	CAP , ELECT	10UF 35V	1	EA
C404	CCKT1H101KB	CAP , CERAMIC	100PF 50V KB	1	EA
C405	CCEA1VH100T	CAP , ELECT	10UF 35V	1	EA
C406	CCEA1VH100T	CAP , ELECT	10UF 35V	1	EA
C407	CCKT1H101KB	CAP , CERAMIC	100PF 50V KB	1	EA
C408	CCEA1VH100T	CAP , ELECT	10UF 35V	1	EA
C409	CCKT1H101KB	CAP , CERAMIC	100PF 50V KB	1	EA
C410	CCKT1H101KB	CAP , CERAMIC	100PF 50V KB	1	EA
C411	HCBS1H101KBT	CAP , CERAMIC	100PF 50V K	1	EA
C412	HCBS1H101KBT	CAP , CERAMIC	100PF 50V K	1	EA
C413	HCBS1H101KBT	CAP , CERAMIC	100PF 50V K	1	EA
C414	HCBS1H101KBT	CAP , CERAMIC	100PF 50V K	1	EA
C415	CCEA1VH100T	CAP , ELECT	10UF 35V	1	EA
C416	CCEA1CH101T	CAP , ELECT	100UF 16V	1	EA
C417	CCEA1CH101T	CAP , ELECT	100UF 16V	1	EA

Ref. Designator	Part Number	Description		Qty	
VIDEO PCB (CUP11849-1)					
C418	HCBS1H223ZFT	CAP , CERAMIC	0.022UF 50V Z	1	EA
C419	CCEA1VH100T	CAP , ELECT	10UF 35V	1	EA
C420	HCBS1H223ZFT	CAP , CERAMIC	0.022UF 50V Z	1	EA
C421	CCEA1CH101T	CAP , ELECT	100UF 16V	1	EA
C422	HCBS1H223ZFT	CAP , CERAMIC	0.022UF 50V Z	1	EA
C423	CCEA1CH101T	CAP , ELECT	100UF 16V	1	EA
C424	CCEA1VH100T	CAP , ELECT	10UF 35V	1	EA
C425	CCEA1VH100T	CAP , ELECT	10UF 35V	1	EA
C426	CCEA1VH100T	CAP , ELECT	10UF 35V	1	EA
C427	HCBS1H223ZFT	CAP , CERAMIC	0.022UF 50V Z	1	EA
C428	CCEA1CH101T	CAP , ELECT	100UF 16V	1	EA
C429	HCBS1H223ZFT	CAP , CERAMIC	0.022UF 50V Z	1	EA
C430	CCEA1CH101T	CAP , ELECT	100UF 16V	1	EA
C431	CCEA1VH100T	CAP , ELECT	10UF 35V	1	EA
C432	CCEA1VH100T	CAP , ELECT	10UF 35V	1	EA
C436	HCBS1H223ZFT	CAP , CERAMIC	0.022UF 50V Z	1	EA
C437	CCEA1CH101T	CAP , ELECT	100UF 16V	1	EA
C438	HCBS1H223ZFT	CAP , CERAMIC	0.022UF 50V Z	1	EA
C439	CCEA1CH101T	CAP , ELECT	100UF 16V	1	EA
C442	HCBS1H103ZFT	CAP , CERAMIC	0.01UF 50V Z	1	EA
C443	CCEA1VH100T	CAP , ELECT	10UF 35V	1	EA
C444	CCEA1VH100T	CAP , ELECT	10UF 35V	1	EA
C445	HCBS1H103ZFT	CAP , CERAMIC	0.01UF 50V Z	1	EA
C446	CCEA1VH100T	CAP , ELECT	10UF 35V	1	EA
C447	CCEA1VH100T	CAP , ELECT	10UF 35V	1	EA
C448	HCBS1H223ZFT	CAP , CERAMIC	0.022UF 50V Z	1	EA
C449	CCEA1CH101T	CAP , ELECT	100UF 16V	1	EA
C450	HCBS1H223ZFT	CAP , CERAMIC	0.022UF 50V Z	1	EA
C451	CCEA1CH101T	CAP , ELECT	100UF 16V	1	EA
C452	HCBS1H223ZFT	CAP , CERAMIC	0.022UF 50V Z	1	EA
C453	CCEA1CH101T	CAP , ELECT	100UF 16V	1	EA
C454	HCBS1H223ZFT	CAP , CERAMIC	0.022UF 50V Z	1	EA
C455	CCEA1CH101T	CAP , ELECT	100UF 16V	1	EA
C456	HCBS1H104ZFT	CAP , CERAMIC	0.1UF 50V Z	1	EA
C457	CCEA1CH101T	CAP , ELECT	100UF 16V	1	EA
C458	CCEA1CH101T	CAP , ELECT	100UF 16V	1	EA
C459	HCBS1H104ZFT	CAP , CERAMIC	0.1UF 50V Z	1	EA
C461	CCEA1CH101T	CAP , ELECT	100UF 16V	1	EA
C462	CCEA1CH101T	CAP , ELECT	100UF 16V	1	EA
C463	HCBS1H473ZFT	CAP , CERAMIC	0.047UF 50V Z	1	EA
C464	CCEA1VH100T	CAP , ELECT	10UF 35V	1	EA
C501	HCBS1H330JT	CAP , CERAMIC	33PF 50V	1	EA
C502	HCBS1H330JT	CAP , CERAMIC	33PF 50V	1	EA
C503	HCBS1H181KBT	CAP , CERAMIC	180PF 50V K	1	EA
C504	CCEA1HHR47T	CAP , ELECT	0.47UF 50V	1	EA
C505	HCBS1H223ZFT	CAP , CERAMIC	0.022UF 50V Z	1	EA
C506	CCEA1AH471T	CAP , ELECT	470UF 10V	1	EA
C507	CCCT1H220JC	CAP , CERAMIC	22PF 50V JC	1	EA
C508	CCCT1H270JC	CAP , CERAMIC	22PF 50V JC	1	EA
C509	CCEA1HH1R0T	CAP , ELECT	1UF 50V	1	EA
C510	CCEA1HH1R0T	CAP , ELECT	1UF 50V	1	EA
C511	HCQ11H682JZT	CAP , MYLAR	6800PF 50V J	1	EA
C512	CCEA1HH0R1T	CAP , ELECT	0.1UF 50V	1	EA
C513	HCBS1H560JT	CAP , CERAMIC	56PF 50V J	1	EA
C514	HCBS1H220JCT	CAP , CERAMIC	22PF 50V J	1	EA
C515	CCEA1AH471T	CAP , ELECT	470UF 10V	1	EA
C517	HCBS1H223ZFT	CAP , CERAMIC	0.022UF 50V Z	1	EA
C518	HCBS1H223ZFT	CAP , CERAMIC	0.022UF 50V Z	1	EA
C519	CCFT1H104ZF	CAP , SEMICONDUCTOR	0.1UF 50V ZF	1	EA
C523	C3A206	WIRE , COPPER	SN95/PB5 , 0.6		
C555	CCEA1AH471T	CAP , ELECT	470UF 10V	1	EA

Ref. Designator	Part Number	Description		Qty	
VIDEO PCB (CUP11849-1)					
C556	CCEA1CH101T	CAP , ELECT	100UF 16V	1	EA
C557	CCEA1CH101T	CAP , ELECT	100UF 16V	1	EA
C561	CCEA1CH101T	CAP , ELECT	100UF 16V	1	EA
C568	HCBS1H104ZFT	CAP , CERAMIC	0.1UF 50V Z	1	EA
C520	CCEA0JKR3222E	CAP , ELECT	2200UF 6.3V	1	EA
C590	CCCT1H220JC	CAP , CERAMIC	22PF 50V JC	1	EA
C943	CCEA1HH2R2T	CAP , ELECT	2.2UF 50V	1	EA
<i>Semiconductors</i>					
D401	HVD1SS133MT	DIODE	1SS133T	1	EA
D402	HVD1SS133MT	DIODE	1SS133T	1	EA
D403	HVD1SS133MT	DIODE	1SS133T	1	EA
D404	HVD1SS133MT	DIODE	1SS133T	1	EA
D405	HVD1SS133MT	DIODE	1SS133T	1	EA
L501	HLQ02C101JT	COIL , AXIAL	100UH,J	1	EA
L502	KLQ5R6J405T	COIL, PEAKING(RADIAL)	5.6UH J 4X5	1	EA
Q402	HVTKSA733CYT	TRANSISTOR	KSA733CY	1	EA
Q403	HVTKRA107MT	TRANSISTOR	KRA107M	1	EA
Q404	HVTKRC107MT	TRANSISTOR	KRC107M	1	EA
Q405	HVTKSA733CYT	TRANSISTOR	KSA733CY	1	EA
Q406	HVTKRA107MT	TRANSISTOR	KRA107M	1	EA
Q407	HVTKRC107MT	TRANSISTOR	KRC107M	1	EA
Q408	HVTKRC107MT	TRANSISTOR	KRC107M	1	EA
Q501	HVTKSC2785YT	TRANSISTOR	KSC2785Y(DEAD)	1	EA
Q502	HVTKSA1175YT	TRANSISTOR	KSA1175Y(DEAD)	1	EA
Q556	HVTKSA1175YT	TRANSISTOR	KSA1175Y(DEAD)	1	EA
Q568	HVTKTC2874BT	TRANSISTOR , MUTE	KTC2874B	1	EA
Q569	HVTKRC107MT	TRANSISTOR	KRC107M	1	EA
IC41	HVINJM2296M	I.C , VIDEO SW (NJM2296M)	JRC	1	EA
IC42	HVINJM2296M	I.C , VIDEO SW (NJM2296M)	JRC	1	EA
IC43	HVINJM2296M	I.C , VIDEO SW (NJM2296M)	JRC	1	EA
IC44	HVIHCF4053M013T	I.C (HCF4053) TRIPLE 2 CHAN MULTPLX	ST	1	EA
IC45	HVIHCF4053M013T	I.C (HCF4053) TRIPLE 2 CHAN MULTPLX	ST	1	EA
IC46	HVINJM2581MTE1	I.C (NJM2581M) 3ch VIDEO AMPLIFIER	JRC	1	EA
IC47	HVIMM1511XNRE	IC, Y/C-MIX (MM1511) VIDEO SWITCH	MITSUMI	1	EA
IC52	HVI74ACT04MTR	I.C , HEX (74ACT04)	FAIRCHILD	1	EA
IC48	CVIL7805CPNA	I.C, REGULATOR (L7805CP)	ASS'Y	1	EA
IC49	CVIL7905CPNA	I.C, REGULATOR (L7905CP)	ASS'Y	1	EA
	HVIL7805CP	I.C, REGULATOR (L7805CP)	ST	1	EA
	HVIL7905CP	I.C, REGULATOR (L7905CP)	ST	1	EA
IC51	HVILC74763M	I.C , OSD (LC74763M)	SANYO	1	EA
<i>Resistors</i>					
R401	CRD20TJ750T	RES , CARBON	75 OHM 1/5W J	1	EA
R402	CRD20TJ750T	RES , CARBON	75 OHM 1/5W J	1	EA
R403	CRD20TJ332T	RES , CARBON	3.3K OHM 1/5W J	1	EA
R404	CRD20TJ750T	RES , CARBON	75 OHM 1/5W J	1	EA
R405	CRD20TJ750T	RES , CARBON	75 OHM 1/5W J	1	EA
R406	CRD20TJ332T	RES , CARBON	3.3K OHM 1/5W J	1	EA
R407	CRD20TJ750T	RES , CARBON	75 OHM 1/5W J	1	EA
R408	CRD20TJ750T	RES , CARBON	75 OHM 1/5W J	1	EA
R409	CRD20TJ750T	RES , CARBON	75 OHM 1/5W J	1	EA
R410	CRD20TJ332T	RES , CARBON	3.3K OHM 1/5W J	1	EA
R411	CRD20TJ750T	RES , CARBON	75 OHM 1/5W J	1	EA
R412	CRD20TJ750T	RES , CARBON	75 OHM 1/5W J	1	EA
R413	CRD20TJ750T	RES , CARBON	75 OHM 1/5W J	1	EA
R414	CRD20TJ332T	RES , CARBON	3.3K OHM 1/5W J	1	EA
R415	CRD20TJ750T	RES , CARBON	75 OHM 1/5W J	1	EA
R416	CRD20TJ332T	RES , CARBON	3.3K OHM 1/5W J	1	EA

Ref. Designator	Part Number	Description		Qty	
VIDEO PCB (CUP11849-1)					
R417	CRD20TJ750T	RES , CARBON	75 OHM 1/5W J	1	EA
R418	CRD20TJ750T	RES , CARBON	75 OHM 1/5W J	1	EA
R419	CRD20TJ750T	RES , CARBON	75 OHM 1/5W J	1	EA
R420	CRD20TJ332T	RES , CARBON	3.3K OHM 1/5W J	1	EA
R421	CRD20TJ750T	RES , CARBON	75 OHM 1/5W J	1	EA
R422	CRD20TJ332T	RES , CARBON	3.3K OHM 1/5W J	1	EA
R423	CRD20TJ750T	RES , CARBON	75 OHM 1/5W J	1	EA
R424	CRD20TJ750T	RES , CARBON	75 OHM 1/5W J	1	EA
R425	CRD20TJ750T	RES , CARBON	75 OHM 1/5W J	1	EA
R426	CRD20TJ332T	RES , CARBON	3.3K OHM 1/5W J	1	EA
R427	CRD20TJ750T	RES , CARBON	75 OHM 1/5W J	1	EA
R428	CRD20TJ332T	RES , CARBON	3.3K OHM 1/5W J	1	EA
R430	CRD20TJ1R8T	RES , CARBON	1.8 OHM 1/5W J	1	EA
R431	CRD20TJ102T	RES , CARBON	1K OHM 1/5W J	1	EA
R432	CRD20TJ1R0T	RES , CARBON	1 OHM 1/5W J	1	EA
R433	CRD20TJ102T	RES , CARBON	1K OHM 1/5W J	1	EA
R434	CRD20TJ102T	RES , CARBON	1K OHM 1/5W J	1	EA
R435	CRD20TJ102T	RES , CARBON	1K OHM 1/5W J	1	EA
R436	CRD20TJ102T	RES , CARBON	1K OHM 1/5W J	1	EA
R437	CRD20TJ102T	RES , CARBON	1K OHM 1/5W J	1	EA
R438	CRD25TJ1R0T	RES , CARBON	1 OHM 1/4W J	1	EA
R439	CRD20TJ750T	RES , CARBON	75 OHM 1/5W J	1	EA
R440	CRD20TJ1R8T	RES , CARBON	1.8 OHM 1/5W J	1	EA
R441	CRD20TJ102T	RES , CARBON	1K OHM 1/5W J	1	EA
R442	CRD20TJ102T	RES , CARBON	1K OHM 1/5W J	1	EA
R443	CRD20TJ102T	RES , CARBON	1K OHM 1/5W J	1	EA
R444	CRD20TJ102T	RES , CARBON	1K OHM 1/5W J	1	EA
R445	CRD20TJ1R0T	RES , CARBON	1 OHM 1/5W J	1	EA
R446	CRD20TJ102T	RES , CARBON	1K OHM 1/5W J	1	EA
R447	CRD20TJ750T	RES , CARBON	75 OHM 1/5W J	1	EA
R448	CRD20TJ1R8T	RES , CARBON	1.8 OHM 1/5W J	1	EA
R449	CRD20TJ102T	RES , CARBON	1K OHM 1/5W J	1	EA
R450	CRD20TJ102T	RES , CARBON	1K OHM 1/5W J	1	EA
R451	CRD20TJ102T	RES , CARBON	1K OHM 1/5W J	1	EA
R452	CRD20TJ102T	RES , CARBON	1K OHM 1/5W J	1	EA
R456	CRD20TJ680T	RES , CARBON	68 OHM 1/5W J	1	EA
R457	CRD20TJ333T	RES , CARBON	33K OHM 1/5W J	1	EA
R458	CRD20TJ123T	RES , CARBON	12K OHM 1/5W J	1	EA
R459	CRD20TJ680T	RES , CARBON	68 OHM 1/5W J	1	EA
R460	CRD20TJ333T	RES , CARBON	33K OHM 1/5W J	1	EA
R461	CRD20TJ123T	RES , CARBON	12K OHM 1/5W J	1	EA
R462	CRD20TJ102T	RES , CARBON	1K OHM 1/5W J	1	EA
R463	CRD20TJ103T	RES , CARBON	10K OHM 1/5W J	1	EA
R464	CRD20TJ103T	RES , CARBON	10K OHM 1/5W J	1	EA
R465	CRD20TJ103T	RES , CARBON	10K OHM 1/5W J	1	EA
R467	CRD20TJ103T	RES , CARBON	10K OHM 1/5W J	1	EA
R468	CRD20TJ100T	RES , CARBON	10 OHM 1/5W J	1	EA
R469	CRD20TJ100T	RES , CARBON	10 OHM 1/5W J	1	EA
R470	CRD20TJ100T	RES , CARBON	10 OHM 1/5W J	1	EA
R471	CRD20TJ100T	RES , CARBON	10 OHM 1/5W J	1	EA
R472	CRD20TJ151T	RES , CARBON	150 OHM 1/5W J	1	EA
R473	CRD20TJ181T	RES , CARBON	180 OHM 1/5W J	1	EA
R474	CRD20TJ1R8T	RES , CARBON	1.8 OHM 1/5W J	1	EA
R475	CRD20TJ1R0T	RES , CARBON	1 OHM 1/5W J	1	EA
R476	CRD25TJ101T	RES , CARBON	100 OHM 1/4W J	1	EA
R477	CRD20TJ2R2T	RES , CARBON	2.2 OHM 1/5W J	1	EA
R479	CRD20TJ181T	RES , CARBON	180 OHM 1/5W J	1	EA
R481	CRD20TJ183T	RES , CARBON	18K OHM 1/5W J	1	EA
R483	CRD20TJ103T	RES , CARBON	10K OHM 1/5W J	1	EA
R484	CRD20TJ104T	RES , CARBON	100K OHM 1/5W J	1	EA
R485	CRD20TJ103T	RES , CARBON	10K OHM 1/5W J	1	EA

Ref. Designator	Part Number	Description		Qty	
VIDEO PCB (CUP11849-1)					
R501	CRD20TJ102T	RES , CARBON	1K OHM 1/5W J	1	EA
R502	CRD20TJ102T	RES , CARBON	1K OHM 1/5W J	1	EA
R503	CRD20TJ102T	RES , CARBON	1K OHM 1/5W J	1	EA
R504	CRD20TJ104T	RES , CARBON	100K OHM 1/5W J	1	EA
R505	CRD20TJ102T	RES , CARBON	1K OHM 1/5W J	1	EA
R506	CRD20TJ102T	RES , CARBON	1K OHM 1/5W J	1	EA
R507	CRD20TJ102T	RES , CARBON	1K OHM 1/5W J	1	EA
R508	CRD20TJ682T	RES , CARBON	6.8K OHM 1/5W J	1	EA
R509	CRD20TJ152T	RES , CARBON	1.5K OHM 1/5W J	1	EA
R510	CRD20TJ393T	RES , CARBON	39K OHM 1/5W J	1	EA
R511	CRD20TJ222T	RES , CARBON	2.2K OHM 1/5W J	1	EA
R512	CRD20TJ271T	RES , CARBON	270 OHM 1/5W J	1	EA
R513	CRD20TJ822T	RES , CARBON	8.2K OHM 1/5W J	1	EA
R514	CRD20TJ103T	RES , CARBON	10K OHM 1/5W J	1	EA
R516	CRD20TJ202T	RES , CARBON	2K OHM 1/5W J	1	EA
R517	CRD20TJ273T	RES , CARBON	27K OHM 1/5W J	1	EA
R555	CRD20TJ101T	RES , CARBON	100 OHM 1/5W J	1	EA
R556	CRD20TJ183T	RES , CARBON	18K OHM 1/5W J	1	EA
R558	CRD20TJ102T	RES , CARBON	1K OHM 1/5W J	1	EA
R568	CRD20TJ223T	RES , CARBON	22K OHM 1/5W J	1	EA
R569	CRD20TJ223T	RES , CARBON	22K OHM 1/5W J	1	EA
<i>Miscellaneous</i>					
BN14	CWB4F232450PU	WIRE ASS'Y	WIRE	1	EA
BN91	CWB4FE53130PU	WIRE ASS'Y	WIRE	1	EA
CN14	CJP06GA19ZY	WAFER, STRAIGHT, 6PIN	WAFER	1	EA
CN41	CJP06GA19ZY	WAFER, STRAIGHT, 6PIN	WAFER	1	EA
CN43	CJP13GA115ZY	WAFER , CARD CABLE	WAFER	1	EA
CN52	CJP05GA19ZY	WAFER, STRAIGHT, 5PIN	WAFER	1	EA
ET04	CMD1A569	BRACKET , PCB	BRACKET	1	EA
ET05	CMD1A569	BRACKET , PCB	BRACKET	1	EA
	CMY1A218	HEAT SINK(TR)	HEAT SINK	1	EA
	CTB3+8J	SCREW	SCREW	1	EA
	CMY1A218	HEAT SINK(TR)	HEAT SINK	1	EA
	CTB3+8J	SCREW	SCREW	1	EA
JK41	CJJ9N001Z	JACK , S-VIDEO (2P/H)	JACK	1	EA
JK42	CJJ9N001Z	JACK , S-VIDEO (2P/H)	JACK	1	EA
JK43	CJJ9S001Z	JACK , S-VIDEO (3P/H)	JACK	1	EA
JK48	CJJ4N043Z	JACK , BOARD	JACK	1	EA
JK49	CJJ4N043Z	JACK , BOARD	JACK	1	EA
JK50	CJJ4S010Z	JACK , BOARD	JACK	1	EA
JW11	CWEP202110VV	WIRE	WIRE	1	EA
X501	HOX14318E220C	CRYSTAL	14.318Mhz	1	EA
OUTLET PCB (CUP11849-7)					
C124	HCQE2E104KDE	CAP , LINE ACROSS	0.1UF	1	EA
CN21	KJP02GA89ZM	WAFER	WAFER	1	EA
CN84	KJP02KA060ZY	WAFER	WAFER	1	EA
F901	KBA2D2500TLET	FUSE	2.5A	1	EA
F902	KBA2D2500TLET	FUSE	2.5A	1	EA
OL91	KJJ7A015Z	OUTLET , AC(UL/2P/SEP)	OUTLET	1	EA
COMPONENT PCB (CUP11849-2)					
<i>Capacitors</i>					
C601	HCBS1H220JCT	CAP , CERAMIC	22PF 50V J	1	EA
C602	HCBS1H220JCT	CAP , CERAMIC	22PF 50V J	1	EA

Ref. Designator	Part Number	Description		Qty	
COMPONENT PCB (CUP11849-2)					
C603	HCBS1H220JCT	CAP , CERAMIC	22PF 50V J	1	EA
C604	HCBS1H220JCT	CAP , CERAMIC	22PF 50V J	1	EA
C605	HCBS1H220JCT	CAP , CERAMIC	22PF 50V J	1	EA
C606	HCBS1H220JCT	CAP , CERAMIC	22PF 50V J	1	EA
C607	HCBS1H220JCT	CAP , CERAMIC	22PF 50V J	1	EA
C608	HCBS1H220JCT	CAP , CERAMIC	22PF 50V J	1	EA
C609	HCBS1H220JCT	CAP , CERAMIC	22PF 50V J	1	EA
C610	HCBS1H223ZFT	CAP , CERAMIC	0.022UF 50V Z	1	EA
C611	CCEA1CKS470T	CAP , ELECT	47UF/16V	1	EA
C612	HCBS1H223ZFT	CAP , CERAMIC	0.022UF 50V Z	1	EA
C613	CCEA1CKS470T	CAP , ELECT	47UF/16V	1	EA
C614	HCBS1H103ZFT	CAP , CERAMIC	0.01UF 50V Z	1	EA
C615	CCEA1VH100T	CAP , ELECT	10UF 35V	1	EA
C616	CCEA1VH100T	CAP , ELECT	10UF 35V	1	EA
<i>Semiconductors</i>					
D601	HVD1SS133MT	DIODE	1SS133T	1	EA
D602	HVD1SS133MT	DIODE	1SS133T	1	EA
IC61	HVINJM2586AMTE1	I.C , VIDEO SW (NJM2586A)	JRC	1	EA
IC62	HVIHCF4053M013T	I.C (HCF4053) TRIPLE 2 CHAN MULTPLX	ST	1	EA
Q601	HVTKRA107MT	TRANSISTOR	KRA107M	1	EA
Q602	HVTKSA733CYT	TRANSISTOR	KSA733CY	1	EA
Q603	HVTKRC107MT	TRANSISTOR	KRC107M	1	EA
<i>Resistors</i>					
R601	CRD20TJ750T	RES , CARBON	75 OHM 1/5W J	1	EA
R602	CRD20TJ750T	RES , CARBON	75 OHM 1/5W J	1	EA
R603	CRD20TJ750T	RES , CARBON	75 OHM 1/5W J	1	EA
R604	CRD20TJ750T	RES , CARBON	75 OHM 1/5W J	1	EA
R605	CRD20TJ750T	RES , CARBON	75 OHM 1/5W J	1	EA
R606	CRD20TJ750T	RES , CARBON	75 OHM 1/5W J	1	EA
R607	CRD20TJ750T	RES , CARBON	75 OHM 1/5W J	1	EA
R608	CRD20TJ750T	RES , CARBON	75 OHM 1/5W J	1	EA
R609	CRD20TJ750T	RES , CARBON	75 OHM 1/5W J	1	EA
R610	CRD20TJ4R7T	RES , CARBON	4.7 OHM 1/5W	1	EA
R611	CRD20TJ4R7T	RES , CARBON	4.7 OHM 1/5W	1	EA
R612	CRD20TJ472T	RES , CARBON	4.7K OHM 1/5W J	1	EA
R614	CRD25TJ750T	RES , CARBON	75 OHM 1/4W J	1	EA
R615	CRD20TJ750T	RES , CARBON	75 OHM 1/5W J	1	EA
R616	CRD20TJ680T	RES , CARBON	68 OHM 1/5W J	1	EA
R617	CRD20TJ333T	RES , CARBON	33K OHM 1/5W J	1	EA
R618	CRD20TJ103T	RES , CARBON	10K OHM 1/5W J	1	EA
R619	CRD20TJ123T	RES , CARBON	12K OHM 1/5W J	1	EA
<i>Miscellaneous</i>					
JK61	CJJ4L009Z	JACK 9P (RRR/BBB/GGG)	JACK	1	EA
CN62	CJP04GA19ZY	WAFER, STRAIGHT, 4PIN	WAFER	1	EA
DIGITAL IN/OUT PCB (CUP11849-13)					
<i>Capacitors</i>					
C750	CCEA1AH471T	CAP , ELECT	470UF 10V	1	EA
C751	CCEA1AH471T	CAP , ELECT	470UF 10V	1	EA
C752	HCEA1AH471T	CAP , ELECT	470UF 10V	1	EA
C753	HCBS1H181KBT	CAP , CERAMIC	180PF 50V K	1	EA
C754	HCBS1H181KBT	CAP , CERAMIC	180PF 50V K	1	EA
C755	HCBS1H181KBT	CAP , CERAMIC	180PF 50V K	1	EA

Ref. Designator	Part Number	Description		Qty	
DIGITAL IN/OUT PCB (CUP11849-13)					
C756	HCBS1H104ZFT	CAP , CERAMIC	0.1UF 50V Z	1	EA
C757	HCBS1H104ZFT	CAP , CERAMIC	0.1UF 50V Z	1	EA
C758	HCBS1H104ZFT	CAP , CERAMIC	0.1UF 50V Z	1	EA
C759	HCBS1H101KBT	CAP , CERAMIC	100PF 50V K	1	EA
C760	CCKT1H473ZF	CAP , CERAMIC	0.047UF 50V ZF	1	EA
C761	CCEA1CH101T	CAP , ELECT	100UF 16V	1	EA
C762	CCEA1CH101T	CAP , ELECT	100UF 16V	1	EA
C763	HCBS1H104ZFT	CAP , CERAMIC	0.1UF 50V Z	1	EA
<i>Semiconductors</i>					
IC72	HVI74HCU04AFNG	I.C , INVERTER (74HCU04)	TOSHIBA	1	EA
<i>Resistors</i>					
R750	CRD20TJ103T	RES , CARBON	10K OHM 1/5W J	1	EA
R751	CRD20TJ103T	RES , CARBON	10K OHM 1/5W J	1	EA
R752	CRD20TJ103T	RES , CARBON	10K OHM 1/5W J	1	EA
R753	CRD20TJ1R0T	RES , CARBON	1 OHM 1/5W J	1	EA
R754	CRD20TJ1R0T	RES , CARBON	1 OHM 1/5W J	1	EA
R755	CRD20TJ1R0T	RES , CARBON	1 OHM 1/5W J	1	EA
R756	CRD20TJ750T	RES , CARBON	75 OHM 1/5W J	1	EA
R757	CRD20TJ750T	RES , CARBON	75 OHM 1/5W J	1	EA
R758	CRD20TJ750T	RES , CARBON	75 OHM 1/5W J	1	EA
R759	CRD20TJ100T	RES , CARBON	10 OHM 1/5W J	1	EA
R760	CRD20TJ241T	RES , CARBON	240OHM 1/5W J	1	EA
R761	CRD20TJ750T	RES , CARBON	75 OHM 1/5W J	1	EA
R762	CRD20TJ1R0T	RES , CARBON	1 OHM 1/5W J	1	EA
R763	CRD20TJ1R0T	RES , CARBON	1 OHM 1/5W J	1	EA
R764	CRD20TJ102T	RES , CARBON	1K OHM 1/5W J	1	EA
R765	CRD20TJ104T	RES , CARBON	100K OHM 1/5W J	1	EA
R766	CRD20TJ472T	RES , CARBON	4.7K OHM 1/5W J	1	EA
R767	CRD20TJ472T	RES , CARBON	4.7K OHM 1/5W J	1	EA
R768	CRD20TJ472T	RES , CARBON	4.7K OHM 1/5W J	1	EA
R770	CRD20TJ104T	RES , CARBON	100K OHM 1/5W J	1	EA
R771	CRD20TJ102T	RES , CARBON	1K OHM 1/5W J	1	EA
R772	CRD20TJ102T	RES , CARBON	1K OHM 1/5W J	1	EA
R776	CRD20TJ104T	RES , CARBON	100K OHM 1/5W J	1	EA
<i>Miscellaneous</i>					
BN18	KJP12GB143ZP	DIP SOCKET	SOCKET	1	EA
JK75	HJSTORX177L	MODULE , OPTICAL(RX)	OPTICAL JACK	1	EA
JK76	HJSTORX177L	MODULE , OPTICAL(RX)	OPTICAL JACK	1	EA
JK77	HJSTORX177L	MODULE , OPTICAL(RX)	OPTICAL JACK	1	EA
JK78	CJJ4P053Z	JACK , RCA (4P ALL ORG)	JACK	1	EA
JK79	HJSTOTX177L	MODULE , OPTICAL(TX)	OPTICAL JACK	1	EA
POWER TRANS PCB (CUP11849-4,5)					
<i>Capacitors</i>					
C107	CCKT1H103ZF	CAP , CERAMIC	0.01UF 50V ZF	1	EA
C108	CCKT1H103ZF	CAP , CERAMIC	0.01UF 50V ZF	1	EA
C109	CCFT1H104ZF	CAP , SEMICONDUCTOR	0.1UF 50V ZF	1	EA
C110	CCFT1H104ZF	CAP , SEMICONDUCTOR	0.1UF 50V ZF	1	EA
C111	CCKT1H103ZF	CAP , CERAMIC	0.01UF 50V ZF	1	EA
C112	CCKT1H103ZF	CAP , CERAMIC	0.01UF 50V ZF	1	EA
C117	CCEA1HH4R7T	CAP , ELECT	4.7UF 50V	1	EA
C118	CCKT1H103ZF	CAP , CERAMIC	0.01UF 50V ZF	1	EA
C119	CCEA1JH470TS	CAP , ELECT	63V/47UF/105°C	1	EA

Ref. Designator	Part Number	Description		Qty	
POWER TRANS PCB (CUP11849-4,5)					
C120	CCEA1JH470TS	CAP , ELECT	63V/47UF/105°C	1	EA
C121	CCKT1H103ZF	CAP , CERAMIC	0.01UF 50V ZF	1	EA
C122	CCEA2AH101E	CAP , ELECT	100UF	1	EA
C921	HCQ11H104JZT	CAP , MYLAR	0.1UF 50V J	1	EA
C922	HCQ11H104JZT	CAP , MYLAR	0.1UF 50V J	1	EA
C923	HCQ11H104JZT	CAP , MYLAR	0.1UF 50V J	1	EA
C924	HCQ11H104JZT	CAP , MYLAR	0.1UF 50V J	1	EA
C925	HCQ11H103JZT	CAP , MYLAR	0.01UF 50V J	1	EA
C926	HCQ11H103JZT	CAP , MYLAR	0.01UF 50V J	1	EA
C927	HCQ11H103JZT	CAP , MYLAR	0.01UF 50V J	1	EA
C928	HCQ11H103JZT	CAP , MYLAR	0.01UF 50V J	1	EA
C931	HCQ11H473JZT	CAP , MYLAR	0.047UF 50V J	1	EA
C932	HCQ11H473JZT	CAP , MYLAR	0.047UF 50V J	1	EA
C933	HCQ11H473JZT	CAP , MYLAR	0.047UF 50V J	1	EA
C934	HCQ11H473JZT	CAP , MYLAR	0.047UF 50V J	1	EA
C947	CCFT1H104ZF	CAP , SEMICONDUCTOR	0.1UF 50V ZF	1	EA
C948	CCKT1H103ZF	CAP , CERAMIC	0.01UF 50V ZF	1	EA
C949	CCKT1H103ZF	CAP , CERAMIC	0.01UF 50V ZF	1	EA
C951	CCEA1HH102E	CAP , ELECT	1000UF , 50V	1	EA
<i>Semiconductors</i>					
D101	HVDMTZJ15BT	DIODE , ZENER	15V 1/2W	1	EA
D102	HVDMTZJ27BT	DIODE , ZENER	27V 1/2W	1	EA
D104	HVD1N5819T	DIODE , SCHOTTKY	1N5819	1	EA
D105	HVD1N5819T	DIODE , SCHOTTKY	1N5819	1	EA
D108	KVD1N4003ST	DIODE	1N4003	1	EA
D109	HVDMTZJ12BT	DIODE , ZENER	12V 1/2W	1	EA
D111	HVDMTZJ12BT	DIODE , ZENER	12V 1/2W	1	EA
D950	KVD1N4003ST	DIODE	1N4003	1	EA
D951	KVD1N4003ST	DIODE	1N4003	1	EA
D991	CVDKBU804FMA	BRIDGE DIODE ASS'Y	KBU804F	1	EA
	HVDKBU804F	DIODE , BRIDGE	BRIDGE DIODE	1	EA
D992	CVDKBU804FMA	BRIDGE DIODE ASS'Y	KBU804F	1	EA
	HVDKBU804F	DIODE , BRIDGE	BRIDGE DIODE	1	EA
Q104	HVTKSC2316YT	TRANSISTOR	KSC2316Y	1	EA
<i>Resistors</i>					
R101	KRD25FJ3R3T	RES , CARBON	3.3 OHM 1/4W	1	EA
R104	KRQ1AJR47H	RES , FUSE	0.47 OHM 1W J	1	EA
R105	KRQ1AJR47H	RES , FUSE	0.47 OHM 1W J	1	EA
R106	CRQ1AJR33H	RES , FUSE	0.33 OHM 1W J	1	EA
R107	CRQ1AJR33H	RES , FUSE	0.33 OHM 1W J	1	EA
R108	CRD20TJ4R7T	RES , CARBON	4.7 OHM 1/5W	1	EA
R109	CRD20TJ100T	RES , CARBON	10 OHM 1/5W J	1	EA
R110	CRD20TJ4R7T	RES , CARBON	4.7 OHM 1/5W	1	EA
R112	CRD20TJ122T	RES , CARBON	1.2K OHM 1/5W J	1	EA
R113	CRD20TJ473T	RES , CARBON	47K OHM 1/5W J	1	EA
R949	CRQ1AJR33H	RES , FUSE	0.33 OHM 1W J	1	EA
R950	CRQ1AJR33H	RES , FUSE	0.33 OHM 1W J	1	EA
<i>Miscellaneous</i>					
BN22	CWB1C902280NN	WIRE , ASS'Y	WIRE	1	EA
BN95	CWB1C002350EN	WIRE ASS'Y	WIRE	1	EA
BN96	CWB1C908150BM	WIRE ASS'Y	WIRE	1	EA
CN13	CJP05GA01ZY	CON WAFER YMW025-05R	WAFER	1	EA
CN19	KJP03GA90ZM	WAFER	WAFER	1	EA
CN20	KJP04GA90ZM	WAFER	WAFER	1	EA
CN81	CJP08GA01ZY	WAFER, STRAIGHT, 8PIN	WAFER	1	EA

Ref. Designator	Part Number	Description		Qty	
POWER TRANS PCB (CUP11849-4,5)					
SW91	KST1A010Z	SW , TACT CN	SWITCH	1	EA
	CMY1A219	HEAT SINK (BRIDGE DIODE)	HEAT SINK	1	EA
	CTB3+12J	SCREW	SCREW	1	EA
	CMY1A219	HEAT SINK (BRIDGE DIODE)	HEAT SINK	1	EA
	CTB3+12J	SCREW	SCREW	1	EA
F903	KBA2C8000TLU	FUSE	8.0A 250V	1	EA
F904	KBA2C8000TLU	FUSE	8.0A 250V	1	EA
F905	KBA2C6300TLUZ	FUSE	6.3A 250V	1	EA
F906	KBA2C6300TLUZ	FUSE	6.3A 250V	1	EA
F907	KBA2C8000TLU	FUSE	8.0A 250V	1	EA
	KJCF5S	HOLDER , FUSE	HOLDER for F903-906	2	EA
	KJCF5S	HOLDER , FUSE	HOLDER for F903-906	2	EA
	KJCF5S	HOLDER , FUSE	HOLDER for F903-906	2	EA
	KJCF5S	HOLDER , FUSE	HOLDER for F903-906	2	EA
	KJCF5S	HOLDER , FUSE	HOLDER for F907	2	EA
BIAS & REGULATOR PCB (CUP11849-6,8)					
<i>Capacitors</i>					
C851	CCEA1HH100T	CAP , ELECT	10UF 50V	1	EA
C852	CCEA1HH100T	CAP , ELECT	10UF 50V	1	EA
C853	CCEA1HH100T	CAP , ELECT	10UF 50V	1	EA
C855	CCEA1HH100T	CAP , ELECT	10UF 50V	1	EA
C856	CCEA1HH100T	CAP , ELECT	10UF 50V	1	EA
C857	CCEA1HH100T	CAP , ELECT	10UF 50V	1	EA
C858	CCEA1HH100T	CAP , ELECT	10UF 50V	1	EA
C929	CCEA1VH472F	CAP , ELECT	4700UF 35V	1	EA
C930	CCEA1VH222F	CAP , ELEC (ANGLE)	2200UF 35V	1	EA
C935	CCKT1H223ZF	CAP , CERAMIC	0.022UF 50V ZF	1	EA
C936	CCKT1H223ZF	CAP , CERAMIC	0.022UF 50V ZF	1	EA
C937	CCKT1H223ZF	CAP , CERAMIC	0.022UF 50V ZF	1	EA
C938	CCEA1EH101T	CAP , ELECT	100UF 25V	1	EA
C939	CCEA1EH101T	CAP , ELECT	100UF 25V	1	EA
C940	CCEA1EH101T	CAP , ELECT	100UF 25V	1	EA
C941	CCEA1CH682E	CAP , ELECT	6800UF , 16V	1	EA
C942	CCEA1HH3R3T	CAP , ELECT	3.3UF 50V	1	EA
<i>Semiconductors</i>					
D904	KVD1N4003ST	DIODE	1N4003	1	EA
D905	KVD1N4003ST	DIODE	1N4003	1	EA
D906	KVD1N4003ST	DIODE	1N4003	1	EA
D907	KVD1N4003ST	DIODE	1N4003	1	EA
D915	HVD1SS133MT	DIODE	1SS133T	1	EA
D916	HVD1SS133MT	DIODE	1SS133T	1	EA
D917	HVDSB2100	DIODE , SCHOTTKY	SB2100	1	EA
D918	HVDSB2100	DIODE , SCHOTTKY	SB2100	1	EA
IC91	HVIL7815CP	I.C, REGULATOR (L7815CP)	ST	1	EA
IC92	HVIL7915CP	I.C, REGULATOR (L7915CP)	ST	1	EA
IC93	HVIL7805CP	I.C, REGULATOR (L7805CP)	ST	1	EA
Q851	HVTKTD600KGR	TRANSISTOR, BIAS	KTD600KGR	1	EA
Q852	HVTKTD600KGR	TRANSISTOR, BIAS	KTD600KGR	1	EA
Q853	HVTKTD600KGR	TRANSISTOR, BIAS	KTD600KGR	1	EA
Q855	HVTKTD600KGR	TRANSISTOR, BIAS	KTD600KGR	1	EA
Q856	HVTKTD600KGR	TRANSISTOR, BIAS	KTD600KGR	1	EA
Q857	HVTKTD600KGR	TRANSISTOR, BIAS	KTD600KGR	1	EA
Q858	HVTKTD600KGR	TRANSISTOR, BIAS	KTD600KGR	1	EA

Ref. Designator	Part Number	Description		Qty	
BIAS & REGULATOR PCB (CUP11849-6,8)					
<i>Resistors</i>					
R874	CRD20TJ331T	RES , CARBON	330 OHM 1/5W J	1	EA
R875	CRD20TJ331T	RES , CARBON	330 OHM 1/5W J	1	EA
R876	CRD20TJ331T	RES , CARBON	330 OHM 1/5W J	1	EA
R878	CRD20TJ331T	RES , CARBON	330 OHM 1/5W J	1	EA
R879	CRD20TJ331T	RES , CARBON	330 OHM 1/5W J	1	EA
R880	CRD20TJ331T	RES , CARBON	330 OHM 1/5W J	1	EA
R881	CRD20TJ331T	RES , CARBON	330 OHM 1/5W J	1	EA
R882	CRD20TJ122T	RES , CARBON	1.2K OHM 1/5W J	1	EA
R883	CRD20TJ122T	RES , CARBON	1.2K OHM 1/5W J	1	EA
R884	CRD20TJ122T	RES , CARBON	1.2K OHM 1/5W J	1	EA
R886	CRD20TJ122T	RES , CARBON	1.2K OHM 1/5W J	1	EA
R887	CRD20TJ122T	RES , CARBON	1.2K OHM 1/5W J	1	EA
R888	CRD20TJ122T	RES , CARBON	1.2K OHM 1/5W J	1	EA
R889	CRD20TJ122T	RES , CARBON	1.2K OHM 1/5W J	1	EA
R912	CRD20TJ153T	RES , CARBON	15K OHM 1/5W J	1	EA
R913	CRD20TJ153T	RES , CARBON	15K OHM 1/5W J	1	EA
R914	CRD20TJ752T	RES , CARBON	7.5K OHM 1/5W J	1	EA
VR81	HVN1RA221B01T	RES , SEMI FIXED(220 OHM)	RH0615C100221	1	EA
VR82	HVN1RA221B01T	RES , SEMI FIXED(220 OHM)	RH0615C100221	1	EA
VR83	HVN1RA221B01T	RES , SEMI FIXED(220 OHM)	RH0615C100221	1	EA
VR85	HVN1RA221B01T	RES , SEMI FIXED(220 OHM)	RH0615C100221	1	EA
VR86	HVN1RA221B01T	RES , SEMI FIXED(220 OHM)	RH0615C100221	1	EA
VR87	HVN1RA221B01T	RES , SEMI FIXED(220 OHM)	RH0615C100221	1	EA
VR88	HVN1RA221B01T	RES , SEMI FIXED(220 OHM)	RH0615C100221	1	EA
<i>Miscellaneous</i>					
CN31	CJP02GB46ZY	WAFER, ANGLE, 2PIN	WAFER	1	EA
CN32	CJP02GB46ZY	WAFER, ANGLE, 2PIN	WAFER	1	EA
CN33	CJP02GB46ZY	WAFER, ANGLE, 2PIN	WAFER	1	EA
CN35	CJP02GB46ZY	WAFER, ANGLE, 2PIN	WAFER	1	EA
CN36	CJP02GB46ZY	WAFER, ANGLE, 2PIN	WAFER	1	EA
CN37	CJP02GB46ZY	WAFER, ANGLE, 2PIN	WAFER	1	EA
CN38	CJP02GB46ZY	WAFER, ANGLE, 2PIN	WAFER	1	EA
CN96	CJP08GA01ZY	WAFER, STRAIGHT, 8PIN	WAFER	1	EA
CN98	HJP08GB131ZK	WAFER	WAFER	1	EA
BN97	CWB2B902200EN	WIRE ASS'Y	WIRE	1	EA
MIC & HP PCB (CUP11849-9)					
<i>Capacitors</i>					
C820	CCEA1VH100T	CAP , ELECT	10UF 35V	1	EA
C821	CCEA1EH470T	CAP , ELECT	47UF 25V	1	EA
C822	CCEA1EH470T	CAP , ELECT	47UF 25V	1	EA
C823	CCEA1VH100T	CAP , ELECT	10UF 35V	1	EA
C824	HCBS1H471KBT	CAP , CERAMIC	470PF 50V	1	EA
C825	HCBS1H151KBT	CAP , CERAMIC	150PF 50V K	1	EA
C826	HCBS1H223ZFT	CAP , CERAMIC	0.022UF 50V Z	1	EA
C827	HCBS1H223ZFT	CAP , CERAMIC	0.022UF 50V Z	1	EA
C828	HCBS1H470JT	CAP , CERAMIC	47PF 50V J	1	EA
C829	CCEA1VH100T	CAP , ELECT	10UF 35V	1	EA
C830	HCBS1H473ZFT	CAP , CERAMIC	0.047UF 50V Z	1	EA
C849	HCBS1H471KBT	CAP , CERAMIC	470PF 50V	1	EA
C850	HCBS1H471KBT	CAP , CERAMIC	470PF 50V	1	EA
C866	CCEA1VH100T	CAP , ELECT	10UF 35V	1	EA
C867	CCEA1VH100T	CAP , ELECT	10UF 35V	1	EA
C868	CCEA1EH470T	CAP , ELECT	47UF 25V	1	EA
C869	CCEA1EH470T	CAP , ELECT	47UF 25V	1	EA

Ref. Designator	Part Number	Description		Qty	
MIC & HP PCB (CUP11849-9)					
C870	HCBS1H681KBT	CAP , CERAMIC	680PF 50V	1	EA
C871	HCBS1H681KBT	CAP , CERAMIC	680PF 50V	1	EA
C872	CCEA1CH331T	CAP , ELECT	330UF 16V	1	EA
C873	CCEA1CH331T	CAP , ELECT	330UF 16V	1	EA
<i>Semiconductors</i>					
IC86	HVINJM4556AL	I.C , HEADPHONE (NJM4556)	JRC	1	EA
IC87	HVINJM2068MDTE1	I.C , OP AMP (NJM2068M)	JRC	1	EA
IC88	HVIHCF4053M013T	I.C (HCF4053) TRIPLE 2 CHAN MULTPLX	ST	1	EA
D801	HVDMTZJ5.6BT	DIODE , ZENER	5.6V 1/2W	1	EA
D802	HVDMTZJ5.6BT	DIODE , ZENER	5.6V 1/2W	1	EA
D803	HVD1SS133MT	DIODE	1SS133T	1	EA
Q734	HVTKTC2874BT	TRANSISTOR, MUTE	KTC2874B	1	EA
Q735	HVTKTC2874BT	TRANSISTOR, MUTE	KTC2874B	1	EA
Q736	HVTKTC2874BT	TRANSISTOR, MUTE	KTC2874B	1	EA
Q737	HVTKTC2874BT	TRANSISTOR, MUTE	KTC2874B	1	EA
Q738	HVTKRC107MT	TRANSISTOR	KRC107M	1	EA
Q739	HVTKRA107MT	TRANSISTOR	KRA107M	1	EA
Q740	HVTKRC107MT	TRANSISTOR	KRC107M	1	EA
<i>Resistors</i>					
R895	CRD20TJ101T	RES , CARBON	100 OHM 1/5W J	1	EA
R896	CRD20TJ101T	RES , CARBON	100 OHM 1/5W J	1	EA
R897	CRD20TJ101T	RES , CARBON	100 OHM 1/5W J	1	EA
R898	CRD20TJ101T	RES , CARBON	100 OHM 1/5W J	1	EA
R899	CRD20TJ104T	RES , CARBON	100K OHM 1/5W J	1	EA
R900	CRD20TJ104T	RES , CARBON	100K OHM 1/5W J	1	EA
R901	CRD20TJ152T	RES , CARBON	1.5K OHM 1/5W J	1	EA
R902	CRD20TJ152T	RES , CARBON	1.5K OHM 1/5W J	1	EA
R903	CRD20TJ102T	RES , CARBON	1K OHM 1/5W J	1	EA
R904	CRD20TJ102T	RES , CARBON	1K OHM 1/5W J	1	EA
R905	CRD20TJ104T	RES , CARBON	100K OHM 1/5W J	1	EA
R906	CRD20TJ104T	RES , CARBON	100K OHM 1/5W J	1	EA
R907	CRD20TJ562T	RES , CARBON	5.6K OHM 1/5W J	1	EA
R908	CRD20TJ562T	RES , CARBON	5.6K OHM 1/5W J	1	EA
R909	CRD20TJ221T	RES , CARBON	220 OHM 1/5W J	1	EA
R910	CRD20TJ221T	RES , CARBON	220 OHM 1/5W J	1	EA
R911	CRD20TJ221T	RES , CARBON	220 OHM 1/5W J	1	EA
R915	CRD20TJ221T	RES , CARBON	220 OHM 1/5W J	1	EA
R918	CRD20TJ562T	RES , CARBON	5.6K OHM 1/5W J	1	EA
R919	CRD20TJ562T	RES , CARBON	5.6K OHM 1/5W J	1	EA
R920	CRD20TJ102T	RES , CARBON	1K OHM 1/5W J	1	EA
R921	CRD20TJ103T	RES , CARBON	10K OHM 1/5W J	1	EA
R922	CRD20TJ102T	RES , CARBON	1K OHM 1/5W J	1	EA
R923	CRD20TJ101T	RES , CARBON	100 OHM 1/5W J	1	EA
R924	CRD20TJ101T	RES , CARBON	100 OHM 1/5W J	1	EA
R925	CRD20TJ680T	RES , CARBON	68 OHM 1/5W J	1	EA
R926	CRD20TJ103T	RES , CARBON	10K OHM 1/5W J	1	EA
R927	CRD20TJ102T	RES , CARBON	1K OHM 1/5W J	1	EA
R928	CRD20TJ102T	RES , CARBON	1K OHM 1/5W J	1	EA
R929	CRD20TJ562T	RES , CARBON	5.6K OHM 1/5W J	1	EA
R930	CRD20TJ103T	RES , CARBON	10K OHM 1/5W J	1	EA
R931	CRD20TJ104T	RES , CARBON	100K OHM 1/5W J	1	EA
R932	CRD20TJ104T	RES , CARBON	100K OHM 1/5W J	1	EA
R933	CRD20TJ103T	RES , CARBON	10K OHM 1/5W J	1	EA
R934	CRD20TJ222T	RES , CARBON	2.2K OHM 1/5W J	1	EA
R935	CRD20TJ103T	RES , CARBON	10K OHM 1/5W J	1	EA
R936	CRD20TJ152T	RES , CARBON	1.5K OHM 1/5W J	1	EA
R937	CRD20TJ104T	RES , CARBON	100K OHM 1/5W J	1	EA

Ref. Designator	Part Number	Description		Qty	
MIC & HP PCB (CUP11849-9)					
R957	CRD20TJ101T	RES , CARBON	100 OHM 1/5W J	1	EA
R958	CRD20TJ471T	RES , CARBON	470 OHM 1/5W J	1	EA
<i>Miscellaneous</i>					
RL81	HSL4A011ZE	RELAY	OMI-SS-212L	1	EA
BN16	CWZAVR140BN16	WIRE ASS'Y (SHIELD)	WIRE	1	EA
BN19	CWZAVR335BN19	WIRE ASS'Y	WIRE	1	EA
BN44	CWB2B906350EN	WIRE ASS'Y	WIRE	1	EA
CN15	CJP10GA19ZY	WAFER, STRAIGHT, 10PIN	WAFER	1	EA
CN82	KJP06HA37ZM	WAFER	WAFER	1	EA
CN85	CJP03GA19ZY	WAFER, STRAIGHT, 3PIN	WAFER	1	EA
CN92	CJP05GA19ZY	WAFER, STRAIGHT, 5PIN	WAFER	1	EA
24V REGULATOR PCB (CUP11849-11)					
C950	CCEA1VH101T	CAP , ELECT	100UF 50V	1	EA
C952	CCKT1H223ZF	CAP , CERAMIC	0.022UF 50V ZF	1	EA
C954	CCEA1VH101T	CAP , ELECT	100UF 50V	1	EA
CN90	CJP02GA19ZY	WAFER, 2PIN	WAFER	1	EA
CN95	CJP02GA19ZY	WAFER, 2PIN	WAFER	1	EA
CN97	CJP03GA01ZY	WAFER	WAFER	1	EA
D955	KVD1N4003ST	DIODE	1N4003	1	EA
D956	KVD1N4003ST	DIODE	1N4003	1	EA
IC94	HVINJM7824FA	I.C , REGULATOR(+24V) (NJM7824FA)	JRC	1	EA
R103	CRQ12AJ100T	RES,FUSEBLE 10 OHM (1/2W)	10 OHM 1/2W	1	EA
REMOTE IN/OUT PCB (CUP11849-12)					
C953	HCBS1H104ZFT	CAP , CERAMIC	0.1UF 50V Z	1	EA
CN87	CJP02GA19ZY	WAFER, 2PIN	WAFER	1	EA
CN88	CJP04GA19ZY	WAFER, STRAIGHT, 4PIN	WAFER	1	EA
D952	HVD1SS133MT	DIODE	1SS133T	1	EA
D953	HVD1SS133MT	DIODE	1SS133T	1	EA
D954	HVD1SS133MT	DIODE	1SS133T	1	EA
IC95	BVIKP1010B	IC, PHOTO COUPLER (KP1010)	COSMO	1	EA
IC96	BVIKP1010B	IC, PHOTO COUPLER (KP1010)	COSMO	1	EA
JK94	CJJ2D008Z	JACK , STEREO	JACK	1	EA
JK95	CJJ2D008Z	JACK , STEREO	JACK	1	EA
JK96	CJJ2D008Z	JACK , STEREO	JACK	1	EA
Q995	HVTKRA107MT	TRANSISTOR	KRA107M	1	EA
Q996	HVTKRC104MT	TRANSISTOR	KRC104M	1	EA
R948	CRD20TJ271T	RES , CARBON	270 OHM 1/5W J	1	EA
R951	CRD20TJ103T	RES , CARBON	10K OHM 1/5W J	1	EA
R952	CRD20TJ103T	RES , CARBON	10K OHM 1/5W J	1	EA
R953	CRD20TJ473T	RES , CARBON	47K OHM 1/5W J	1	EA
R954	CRD20TJ470T	RES , CARBON	47 OHM 1/5W J	1	EA
R955	CRD20TJ271T	RES , CARBON	270 OHM 1/5W J	1	EA
R956	CRD20TJ473T	RES , CARBON	47K OHM 1/5W J	1	EA
IPOD PCB (CUP11834Y)					
<i>Capacitors</i>					
C400	HCUS1H104ZF	CAP , CHIP	0.1UF	1	EA
C401	HCUS1H104ZF	CAP , CHIP	0.1UF	1	EA
C402	HCUS1H471JA	CAP , CHIP	470PF	1	EA
C403	HCUS1H471JA	CAP , CHIP	470PF	1	EA
C408	HCEC1CRV2100T	CAP , ELEC (SMD)	10UF / 16V	1	EA
C409	HCEC1CRV2100T	CAP , ELEC (SMD)	10UF / 16V	1	EA

Ref. Designator	Part Number	Description		Qty	
IPOD PCB (CUP11834Y)					
C410	HCEC1HRV21R0T	CAP , ELEC (SMD)	1UF/50	1	EA
C411	HCEC1HRV21R0T	CAP , ELEC (SMD)	1UF/50	1	EA
C416	HCUS1H473ZF	CAP , CHIP	0.047UF	1	EA
C421	HCUS1H471JA	CAP , CHIP	470PF	1	EA
C422	HCUS1H471JA	CAP , CHIP	470PF	1	EA
C423	HCUS1H223KC	CAP , CHIP	2200PF	1	EA
C424	HCUS1H223KC	CAP , CHIP	2200PF	1	EA
C417	CCEA1CH471T	CAP , ELECT	470UF 16V	1	EA
<i>Semiconductors</i>					
D400	HVD1SS355T	DIODE , CHIP	1SS355	1	EA
D401	HVD1SS355T	DIODE , CHIP	1SS355	1	EA
IC41	HVITC9215AF	I.C (TC9215AF) HI V ANALOG SWITCH	TOSHIBA	1	EA
Q400	HVTKRC102S	TRANSISTOR, CHIP	KRC102S	1	EA
Q401	HVTKRC102S	TRANSISTOR, CHIP	KRC102S	1	EA
Q402	HVTKRC102S	TRANSISTOR, CHIP	KRC102S	1	EA
D402	KVD1N4003ST	DIODE	1N4003	1	EA
<i>Resistors</i>					
R400	CRJ10DJ4R7T	RES , CHIP	4.7 OHM	1	EA
R401	CRJ10DJ4R7T	RES , CHIP	4.7 OHM	1	EA
R402	CRJ10DF5493T	RES , CHIP 549KOHM/1608/1%	49K OHM/1608/1%	1	EA
R403	CRJ10DJ0R0T	RES , CHIP	0 OHM	1	EA
R404	CRJ10DJ470T	RES , CHIP	47 OHM	1	EA
R405	CRJ10DJ470T	RES , CHIP	47 OHM	1	EA
R406	CRJ10DJ474T	RES, CHIP	470K OHM	1	EA
R407	CRJ10DJ474T	RES, CHIP	470K OHM	1	EA
R412	CRJ10DJ471T	RES , CHIP	470 OHM	1	EA
R413	CRJ10DJ471T	RES , CHIP	470 OHM	1	EA
R419	CRJ10DJ332T	RES , CHIP	3.3K OHM	1	EA
R420	CRJ10DJ332T	RES , CHIP	3.3K OHM	1	EA
R421	CRJ10DJ223T	RES , CHIP	22K OHM 1/5W J	1	EA
R422	CRJ10DJ224T	RES , CHIP	220K OHM	1	EA
<i>Miscellaneous</i>					
R416	CLZ9Z068Z	COIL,CHOKE	CHOKE COIL	1	EA
CN42	CJP05GB46ZY	WAFER	WAFER	1	EA
CN43	CJP03GB46ZY	WAFER , ANGLE , 3PIN	WAFER	1	EA
CN44	CJP06GB46ZY	WAFER , ANGLE , 6PIN	WAFER	1	EA
ET01	CMD1A570	BRACKET , PCB	BRACKET	1	EA
	CHG1A306	CUSHION	CUSHION	1	EA
JK40	HJJ9L003Z	JACK , IPOD	IPOD JACK	1	EA
MAIN PCB (CUP11579W)					
<i>Capacitors</i>					
C501	CCEA1VH100T	CAP , ELECT	10UF 35V	1	EA
C502	CCEA1VH100T	CAP , ELECT	10UF 35V	1	EA
C503	CCEA1VH100T	CAP , ELECT	10UF 35V	1	EA
C504	CCEA1VH100T	CAP , ELECT	10UF 35V	1	EA
C505	CCEA1VH100T	CAP , ELECT	10UF 35V	1	EA
C506	CCKT1H331KB	CAP , CERAMIC	330PF 50V KB	1	EA
C507	CCKT1H331KB	CAP , CERAMIC	330PF 50V KB	1	EA
C508	CCKT1H331KB	CAP , CERAMIC	330PF 50V KB	1	EA
C509	CCKT1H331KB	CAP , CERAMIC	330PF 50V KB	1	EA
C510	CCKT1H331KB	CAP , CERAMIC	330PF 50V KB	1	EA

Ref. Designator	Part Number	Description		Qty	
MAIN PCB (CUP11579W)					
C561	CCEA1CH101T	CAP , ELECT	100UF 16V	1	EA
C562	CCEA1CH101T	CAP , ELECT	100UF 16V	1	EA
C564	CCEA1CH101T	CAP , ELECT	100UF 16V	1	EA
C566	CCEA1CH101T	CAP , ELECT	100UF 16V	1	EA
C567	CCEA1CH101T	CAP , ELECT	100UF 16V	1	EA
C568	CCEA1CH101T	CAP , ELECT	100UF 16V	1	EA
C569	CCEA1CH101T	CAP , ELECT	100UF 16V	1	EA
C570	CCEA1CH101T	CAP , ELECT	100UF 16V	1	EA
C571	HCBS1H681KBT	CAP , CERAMIC	680PF 50V	1	EA
C572	HCBS1H681KBT	CAP , CERAMIC	680PF 50V	1	EA
C573	HCBS1H681KBT	CAP , CERAMIC	680PF 50V	1	EA
C574	HCBS1H681KBT	CAP , CERAMIC	680PF 50V	1	EA
C575	HCBS1H681KBT	CAP , CERAMIC	680PF 50V	1	EA
C601	CCCT1H120JC	CAP , CERAMIC	12PF 50V JC	1	EA
C602	CCCT1H120JC	CAP , CERAMIC	12PF 50V JC	1	EA
C603	CCCT1H120JC	CAP , CERAMIC	12PF 50V JC	1	EA
C604	CCCT1H120JC	CAP , CERAMIC	12PF 50V JC	1	EA
C605	CCCT1H120JC	CAP , CERAMIC	12PF 50V JC	1	EA
C606	CCCT1H330JC	CAP , CERAMIC	33PF 50V JC	1	EA
C607	CCCT1H330JC	CAP , CERAMIC	33PF 50V JC	1	EA
C608	CCCT1H330JC	CAP , CERAMIC	33PF 50V JC	1	EA
C609	CCCT1H330JC	CAP , CERAMIC	33PF 50V JC	1	EA
C610	CCCT1H330JC	CAP , CERAMIC	33PF 50V JC	1	EA
C681	CCEA1HH100T	CAP , ELECT	10UF 50V	1	EA
C682	CCEA1HH100T	CAP , ELECT	10UF 50V	1	EA
C683	CCEA1HH100T	CAP , ELECT	10UF 50V	1	EA
C684	CCEA1HH100T	CAP , ELECT	10UF 50V	1	EA
C685	CCEA1HH100T	CAP , ELECT	10UF 50V	1	EA
C721	CCKT1H221KB	CAP , CERAMIC	220PF 50V KB	1	EA
C722	CCKT1H221KB	CAP , CERAMIC	220PF 50V KB	1	EA
C723	CCKT1H221KB	CAP , CERAMIC	220PF 50V KB	1	EA
C724	CCKT1H221KB	CAP , CERAMIC	220PF 50V KB	1	EA
C725	CCKT1H221KB	CAP , CERAMIC	220PF 50V KB	1	EA
C726	CCKT1H221KB	CAP , CERAMIC	220PF 50V KB	1	EA
C727	CCKT1H221KB	CAP , CERAMIC	220PF 50V KB	1	EA
C728	CCKT1H221KB	CAP , CERAMIC	220PF 50V KB	1	EA
C801	CCEA1HH100T	CAP , ELECT	10UF 50V	1	EA
C802	CCEA1HH100T	CAP , ELECT	10UF 50V	1	EA
C803	CCCT1H330JC	CAP , CERAMIC	33PF 50V JC	1	EA
C804	CCCT1H330JC	CAP , CERAMIC	33PF 50V JC	1	EA
C805	CCCT1H120JC	CAP , CERAMIC	12PF 50V JC	1	EA
C806	CCCT1H120JC	CAP , CERAMIC	12PF 50V JC	1	EA
C811	CCEA1CH101T	CAP , ELECT	100UF 16V	1	EA
C812	CCEA1CH101T	CAP , ELECT	100UF 16V	1	EA
C813	CCEA1CH101T	CAP , ELECT	100UF 16V	1	EA
C814	CCEA1CH101T	CAP , ELECT	100UF 16V	1	EA
C815	CCKT1H331KB	CAP , CERAMIC	330PF 50V KB	1	EA
C816	CCKT1H331KB	CAP , CERAMIC	330PF 50V KB	1	EA
C817	CCEA1VH100T	CAP , ELECT	10UF 35V	1	EA
C818	CCEA1VKS100T	CAP , ELECT	10UF 35V	1	EA
C819	HCBS1H681KBT	CAP , CERAMIC	680PF 50V	1	EA
C820	HCBS1H681KBT	CAP , CERAMIC	680PF 50V	1	EA
C900	HCQI1H473JZT	CAP , MYLAR	0.047UF 50V J	1	EA
C901	HCQI1H473JZT	CAP , MYLAR	0.047UF 50V J	1	EA
C905	CCKT1H223ZF	CAP , CERAMIC	0.022UF 50V ZF	1	EA
C907	CCEA1CH101T	CAP , ELECT	100UF 16V	1	EA
C908	CCKT1H223ZF	CAP , CERAMIC	0.022UF 50V ZF	1	EA
C910	HCQI1H473JZT	CAP , MYLAR	0.047UF 50V J	1	EA
C911	CCEA1CH471T	CAP , ELECT	470UF 16V	1	EA
C912	CCEA1EH221T	CAP , ELECT	220UF 25V	1	EA
C913	CCFT1H104ZF	CAP , SEMICONDUCTOR	0.1UF 50V ZF	1	EA

Ref. Designator	Part Number	Description		Qty	
MAIN PCB (CUP11579W)					
C914	HCQI1H473JZT	CAP , MYLAR	0.047UF 50V J	1	EA
C917	HCQI1H473JZT	CAP , MYLAR	0.047UF 50V J	1	EA
C918	HCQI1H473JZT	CAP , MYLAR	0.047UF 50V J	1	EA
C919	HCQI1H473JZT	CAP , MYLAR	0.047UF 50V J	1	EA
C924	HCBS1H104ZFT	CAP , CERAMIC	0.1UF 50V Z	1	EA
C925	HCBS1H104ZFT	CAP , CERAMIC	0.1UF 50V Z	1	EA
C932	CCEA1CH101T	CAP , ELECT	100UF 16V	1	EA
C933	CCEA1EH221T	CAP , ELECT	220UF 25V	1	EA
C934	CCKT1H223ZF	CAP , CERAMIC	0.022UF 50V ZF	1	EA
C939	CCEA1HH4R7T	CAP , ELECT	4.7UF 50V	1	EA
C940	CCEA1AH471T	CAP , ELECT	470UF 10V	1	EA
C950	CCEA1CH101T	CAP , ELECT	100UF 16V	1	EA
C971	HCQI1H562JZT	CAP , MYLAR	5600PF 50V J	1	EA
C972	HCQI1H562JZT	CAP , MYLAR	5600PF 50V J	1	EA
C973	HCQI1H562JZT	CAP , MYLAR	5600PF 50V J	1	EA
C974	HCQI1H562JZT	CAP , MYLAR	5600PF 50V J	1	EA
C975	HCQI1H562JZT	CAP , MYLAR	5600PF 50V J	1	EA
C980	HCQI1H562JZT	CAP , MYLAR	5600PF 50V J	1	EA
C981	HCQI1H562JZT	CAP , MYLAR	5600PF 50V J	1	EA
C990	HCQI1H473JZT	CAP , MYLAR	0.047UF 50V J	1	EA
C991	CCEA1HH1R0T	CAP , ELECT	1UF 50V	1	EA
C992	HCQI1H473JZT	CAP , MYLAR	0.047UF 50V J	1	EA
C993	HCQI1H473JZT	CAP , MYLAR	0.047UF 50V J	1	EA
C994	HCQI1H473JZT	CAP , MYLAR	0.047UF 50V J	1	EA
C995	HCQI1H473JZT	CAP , MYLAR	0.047UF 50V J	1	EA
C996	HCQI1H473JZT	CAP , MYLAR	0.047UF 50V J	1	EA
C997	HCQI1H473JZT	CAP , MYLAR	0.047UF 50V J	1	EA
C999	CCKT1H223ZF	CAP , CERAMIC	0.022UF 50V ZF	1	EA
C563	CCEA1CH101T	CAP , ELECT	100UF 16V	1	EA
C565	CCEA1CH101T	CAP , ELECT	100UF 16V	1	EA
C631	CCEA1JH221E	CAP , ELECT	220UF 63V	1	EA
C632	CCEA1JH221E	CAP , ELECT	220UF 63V	1	EA
C633	CCEA1JH221E	CAP , ELECT	220UF 63V	1	EA
C634	CCEA1JH221E	CAP , ELECT	220UF 63V	1	EA
C635	CCEA1JH221E	CAP , ELECT	220UF 63V	1	EA
C636	CCEA1JH221E	CAP , ELECT	220UF 63V	1	EA
C637	CCEA1JH221E	CAP , ELECT	220UF 63V	1	EA
C638	CCEA1JH221E	CAP , ELECT	220UF 63V	1	EA
C639	CCEA1JH221E	CAP , ELECT	220UF 63V	1	EA
C640	CCEA1JH221E	CAP , ELECT	220UF 63V	1	EA
C807	CCEA1JH221E	CAP , ELECT	220UF 63V	1	EA
C808	CCEA1JH221E	CAP , ELECT	220UF 63V	1	EA
C809	CCEA1JH221E	CAP , ELECT	220UF 63V	1	EA
C810	CCEA1JH221E	CAP , ELECT	220UF 63V	1	EA
C902	CCET63VKL5822NK	CAP , ELECT	8200/63V (30*50	1	EA
C904	KCKDKS472ME	CAP , CERAMIC(X1/Y2/SC)	0.0047UF/2.5KV	1	EA
C906	CCEA1EH102E	CAP , ELECT	1000UF 25V	1	EA
C909	CCET63VKL5822NK	CAP , ELECT	8200/63V (30*50	1	EA
C915	CCET63VKL5123NK	CAP , ELECT	12000/63V (30*5	1	EA
C916	CCET63VKL5123NK	CAP , ELECT	12000/63V (30*5	1	EA
<i>Semiconductors</i>					
D501	HVD1SS133MT	DIODE	1SS133T	1	EA
D502	HVD1SS133MT	DIODE	1SS133T	1	EA
D503	HVD1SS133MT	DIODE	1SS133T	1	EA
D504	HVD1SS133MT	DIODE	1SS133T	1	EA
D505	HVD1SS133MT	DIODE	1SS133T	1	EA
D581	HVD1SS133MT	DIODE	1SS133T	1	EA
D582	HVD1SS133MT	DIODE	1SS133T	1	EA
D583	HVD1SS133MT	DIODE	1SS133T	1	EA

Ref. Designator	Part Number	Description		Qty	
MAIN PCB (CUP11579W)					
D584	HVD1SS133MT	DIODE	1SS133T	1	EA
D585	HVD1SS133MT	DIODE	1SS133T	1	EA
D601	HVD1SS133MT	DIODE	1SS133T	1	EA
D801	HVD1SS133MT	DIODE	1SS133T	1	EA
D802	HVD1SS133MT	DIODE	1SS133T	1	EA
D803	HVD1SS133MT	DIODE	1SS133T	1	EA
D804	HVD1SS133MT	DIODE	1SS133T	1	EA
D901	KVD1N4003ST	DIODE	1N4003	1	EA
D902	HVD1SS133MT	DIODE	1SS133T	1	EA
D911	HVD1SS133MT	DIODE	1SS133T	1	EA
D912	HVD1SS133MT	DIODE	1SS133T	1	EA
D914	HVD1SS133MT	DIODE	1SS133T	1	EA
D917	HVD1SS133MT	DIODE	1SS133T	1	EA
D953	HVD1SS133MT	DIODE	1SS133T	1	EA
D954	KVD1N4003SRT	DIODE TW	1N4003	1	EA
D955	KVD1N4003SRT	DIODE TW	1N4003	1	EA
D961	KVD1N4003ST	DIODE	1N4003	1	EA
D962	KVD1N4003ST	DIODE	1N4003	1	EA
D963	KVD1N4003ST	DIODE	1N4003	1	EA
D964	HVD1SS133MT	DIODE	1SS133T	1	EA
D967	HVD1SS133MT	DIODE	1SS133T	1	EA
D968	HVD1SS133MT	DIODE	1SS133T	1	EA
D969	HVD1SS133MT	DIODE	1SS133T	1	EA
D971	HVD1SS133MT	DIODE	1SS133T	1	EA
D972	HVD1SS133MT	DIODE	1SS133T	1	EA
D973	HVD1SS133MT	DIODE	1SS133T	1	EA
D974	HVD1SS133MT	DIODE	1SS133T	1	EA
D975	HVD1SS133MT	DIODE	1SS133T	1	EA
D976	HVD1SS133MT	DIODE	1SS133T	1	EA
Q501	HVTKTA1268GRT	TRANSISTOR	KTA1268GR	1	EA
Q502	HVTKTA1268GRT	TRANSISTOR	KTA1268GR	1	EA
Q503	HVTKTA1268GRT	TRANSISTOR	KTA1268GR	1	EA
Q504	HVTKTA1268GRT	TRANSISTOR	KTA1268GR	1	EA
Q505	HVTKTA1268GRT	TRANSISTOR	KTA1268GR	1	EA
Q511	HVTKTC3200GRT	TRANSISTOR	KTC3200GR	1	EA
Q512	HVTKTC3200GRT	TRANSISTOR	KTC3200GR	1	EA
Q513	HVTKTC3200GRT	TRANSISTOR	KTC3200GR	1	EA
Q514	HVTKTC3200GRT	TRANSISTOR	KTC3200GR	1	EA
Q515	HVTKTC3200GRT	TRANSISTOR	KTC3200GR	1	EA
Q516	HVTKTC3200GRT	TRANSISTOR	KTC3200GR	1	EA
Q517	HVTKTC3200GRT	TRANSISTOR	KTC3200GR	1	EA
Q518	HVTKTC3200GRT	TRANSISTOR	KTC3200GR	1	EA
Q519	HVTKTC3200GRT	TRANSISTOR	KTC3200GR	1	EA
Q520	HVTKTC3200GRT	TRANSISTOR	KTC3200GR	1	EA
Q541	HVTKTC3198YT	TRANSISTOR	KTC3198Y	1	EA
Q542	HVTKTC3198YT	TRANSISTOR	KTC3198Y	1	EA
Q543	HVTKTC3198YT	TRANSISTOR	KTC3198Y	1	EA
Q544	HVTKTC3198YT	TRANSISTOR	KTC3198Y	1	EA
Q545	HVTKTC3198YT	TRANSISTOR	KTC3198Y	1	EA
Q556	HVTKTC3200GRT	TRANSISTOR	KTC3200GR	1	EA
Q557	HVTKTC3200GRT	TRANSISTOR	KTC3200GR	1	EA
Q558	HVTKTC3200GRT	TRANSISTOR	KTC3200GR	1	EA
Q559	HVTKTC3200GRT	TRANSISTOR	KTC3200GR	1	EA
Q560	HVTKTC3200GRT	TRANSISTOR	KTC3200GR	1	EA
Q561	HVTKTC3200GRT	TRANSISTOR	KTC3200GR	1	EA
Q562	HVTKTC3200GRT	TRANSISTOR	KTC3200GR	1	EA
Q563	HVTKTC3200GRT	TRANSISTOR	KTC3200GR	1	EA
Q564	HVTKTC3200GRT	TRANSISTOR	KTC3200GR	1	EA
Q565	HVTKTC3200GRT	TRANSISTOR	KTC3200GR	1	EA
Q601	HVTKTA1268GRT	TRANSISTOR	KTA1268GR	1	EA
Q602	HVTKTA1268GRT	TRANSISTOR	KTA1268GR	1	EA

Ref. Designator	Part Number	Description		Qty	
MAIN PCB (CUP11579W)					
Q603	HVTKTA1268GRT	TRANSISTOR	KTA1268GR	1	EA
Q604	HVTKTA1268GRT	TRANSISTOR	KTA1268GR	1	EA
Q605	HVTKTA1268GRT	TRANSISTOR	KTA1268GR	1	EA
Q681	KVTKSC2785YT	TRANSISTOR	KSC2785Y	1	EA
Q682	KVTKSC2785YT	TRANSISTOR	KSC2785Y	1	EA
Q683	KVTKSC2785YT	TRANSISTOR	KSC2785Y	1	EA
Q684	KVTKSC2785YT	TRANSISTOR	KSC2785Y	1	EA
Q685	KVTKSC2785YT	TRANSISTOR	KSC2785Y	1	EA
Q701	HVTKTC2874BT	TRANSISTOR , MUTE	KTC2874B	1	EA
Q702	HVTKTC2874BT	TRANSISTOR , MUTE	KTC2874B	1	EA
Q703	HVTKTC2874BT	TRANSISTOR , MUTE	KTC2874B	1	EA
Q704	HVTKTC2874BT	TRANSISTOR , MUTE	KTC2874B	1	EA
Q705	HVTKTC2874BT	TRANSISTOR , MUTE	KTC2874B	1	EA
Q706	HVTKTC2874BT	TRANSISTOR , MUTE	KTC2874B	1	EA
Q707	HVTKTC2874BT	TRANSISTOR , MUTE	KTC2874B	1	EA
Q708	HVTKTC2874BT	TRANSISTOR , MUTE	KTC2874B	1	EA
Q801	KVTKSC2785YT	TRANSISTOR	KSC2785Y	1	EA
Q802	KVTKSC2785YT	TRANSISTOR	KSC2785Y	1	EA
Q812	HVTKTA1268GRT	TRANSISTOR	KTA1268GR	1	EA
Q813	HVTKTC3200GRT	TRANSISTOR	KTC3200GR	1	EA
Q814	HVTKTA1268GRT	TRANSISTOR	KTA1268GR	1	EA
Q815	HVTKTC3200GRT	TRANSISTOR	KTC3200GR	1	EA
Q816	HVTKTA1268GRT	TRANSISTOR	KTA1268GR	1	EA
Q817	HVTKTA1268GRT	TRANSISTOR	KTA1268GR	1	EA
Q818	HVTKTC3200GRT	TRANSISTOR	KTC3200GR	1	EA
Q819	HVTKTC3200GRT	TRANSISTOR	KTC3200GR	1	EA
Q820	HVTKTC3200GRT	TRANSISTOR	KTC3200GR	1	EA
Q821	HVTKTC3200GRT	TRANSISTOR	KTC3200GR	1	EA
Q822	HVTKTC3200GRT	TRANSISTOR	KTC3200GR	1	EA
Q823	HVTKTC3200GRT	TRANSISTOR	KTC3200GR	1	EA
Q824	HVTKTC3198YT	TRANSISTOR	KTC3198Y	1	EA
Q825	HVTKTC3198YT	TRANSISTOR	KTC3198Y	1	EA
Q826	HVTKTC2874BT	TRANSISTOR , MUTE	KTC2874B	1	EA
Q827	HVTKTC2874BT	TRANSISTOR , MUTE	KTC2874B	1	EA
Q901	KVTKSC2785YT	TRANSISTOR	KSC2785Y	1	EA
Q902	HVTKRA107MT	TRANSISTOR	KRA107M	1	EA
Q903	HVTKRA107MT	TRANSISTOR	KRA107M	1	EA
Q904	HVTKRC107MT	TRANSISTOR	KRC107M	1	EA
Q911	HVTKTA1271YT	TRANSISTOR	KTA1271Y	1	EA
Q912	HVTKTA1271YT	TRANSISTOR	KTA1271Y	1	EA
Q913	HVTKTA1271YT	TRANSISTOR	KTA1271Y	1	EA
Q914	HVTKTA1271YT	TRANSISTOR	KTA1271Y	1	EA
Q915	KVTKSC2785YT	TRANSISTOR	KSC2785Y	1	EA
Q916	KVTKSC2785YT	TRANSISTOR	KSC2785Y	1	EA
Q917	KVTKSC2785YT	TRANSISTOR	KSC2785Y	1	EA
Q918	KVTKSC2785YT	TRANSISTOR	KSC2785Y	1	EA
Q938	HVTKRA107MT	TRANSISTOR	KRA107M	1	EA
Q939	HVTKRA107MT	TRANSISTOR	KRA107M	1	EA
Q942	KVTKSC2785YT	TRANSISTOR	KSC2785Y	1	EA
Q943	KVTKSC2785YT	TRANSISTOR	KSC2785Y	1	EA
Q951	HVTKRC107MT	TRANSISTOR	KRC107M	1	EA
Q952	HVTKRA107MT	TRANSISTOR	KRA107M	1	EA
Q960	HVTKRC107MT	TRANSISTOR	KRC107M	1	EA
Q961	HVTKTA1024YT	TRANSISTOR	KTA1024Y	1	EA
Q969	HVTKTC2874BT	TRANSISTOR , MUTE	KTC2874B	1	EA
Q970	HVTKTC2874BT	TRANSISTOR , MUTE	KTC2874B	1	EA
Q971	HVTKTC2874BT	TRANSISTOR , MUTE	KTC2874B	1	EA
Q972	HVTKTC2874BT	TRANSISTOR , MUTE	KTC2874B	1	EA
Q973	HVTKTC2874BT	TRANSISTOR , MUTE	KTC2874B	1	EA
Q991	HVTKRC107MT	TRANSISTOR	KRC107M	1	EA
Q992	HVTKRA107MT	TRANSISTOR	KRA107M	1	EA

Ref. Designator	Part Number	Description		Qty	
MAIN PCB (CUP11579W)					
Q993	HVTKRA107MT	TRANSISTOR	KRA107M	1	EA
Q994	HVTKRC107MT	TRANSISTOR	KRC107M	1	EA
Q652	HVT2SB1647-OKM	TRANSISTOR, POWER	2SB1647	1	EA
Q653	HVT2SB1647-OKM	TRANSISTOR, POWER	2SB1647	1	EA
Q654	HVT2SB1647-OKM	TRANSISTOR, POWER	2SB1647	1	EA
Q655	HVT2SB1647-OKM	TRANSISTOR, POWER	2SB1647	1	EA
Q657	HVT2SD2560-OKM	TRANSISTOR, POWER	2SD2560	1	EA
Q658	HVT2SD2560-OKM	TRANSISTOR, POWER	2SD2560	1	EA
Q659	HVT2SD2560-OKM	TRANSISTOR, POWER	2SD2560	1	EA
Q660	HVT2SD2560-OKM	TRANSISTOR, POWER	2SD2560	1	EA
Q661	HVT2SB1647-OKM	TRANSISTOR, POWER	2SB1647	1	EA
Q670	HVT2SD2560-OKM	TRANSISTOR, POWER	2SD2560	1	EA
Q803	HVT2SD2560-OKM	TRANSISTOR, POWER	2SD2560	1	EA
Q804	HVT2SB1647-OKM	TRANSISTOR, POWER	2SB1647	1	EA
Q805	HVT2SD2560-OKM	TRANSISTOR, POWER	2SD2560	1	EA
Q807	HVT2SB1647-OKM	TRANSISTOR, POWER	2SB1647	1	EA
Q858	HVT2SA1360O	TRANSISTOR	2SA1360O	1	EA
Q871	HVT2SA1360O	TRANSISTOR	2SA1360O	1	EA
Q872	HVT2SA1360O	TRANSISTOR	2SA1360O	1	EA
Q874	HVT2SA1360O	TRANSISTOR	2SA1360O	1	EA
Q875	HVT2SA1360O	TRANSISTOR	2SA1360O	1	EA
Q876	HVT2SA1360O	TRANSISTOR	2SA1360O	1	EA
Q877	HVT2SA1360O	TRANSISTOR	2SA1360O	1	EA
Q881	HVT2SC3423O	TRANSISTOR	2SC3423O	1	EA
Q882	HVT2SC3423O	TRANSISTOR	2SC3423O	1	EA
Q883	HVT2SC3423O	TRANSISTOR	2SC3423O	1	EA
Q884	HVT2SC3423O	TRANSISTOR	2SC3423O	1	EA
Q885	HVT2SC3423O	TRANSISTOR	2SC3423O	1	EA
Q886	HVT2SC3423O	TRANSISTOR	2SC3423O	1	EA
Q887	HVT2SC3423O	TRANSISTOR	2SC3423O	1	EA
IC94	HVIMC7805C	I.C, REGULATOR (MC7805)	KA7805-ABTU	1	EA
<i>Resistors</i>					
R501	CRD20TJ433T	RES , CARBON	43K OHM 1/5W J	1	EA
R502	CRD20TJ433T	RES , CARBON	43K OHM 1/5W J	1	EA
R503	CRD20TJ433T	RES , CARBON	43K OHM 1/5W J	1	EA
R504	CRD20TJ433T	RES , CARBON	43K OHM 1/5W J	1	EA
R505	CRD20TJ433T	RES , CARBON	43K OHM 1/5W J	1	EA
R506	CRD20TJ333T	RES , CARBON	33K OHM 1/5W J	1	EA
R507	CRD20TJ333T	RES , CARBON	33K OHM 1/5W J	1	EA
R508	CRD20TJ333T	RES , CARBON	33K OHM 1/5W J	1	EA
R509	CRD20TJ333T	RES , CARBON	33K OHM 1/5W J	1	EA
R510	CRD20TJ333T	RES , CARBON	33K OHM 1/5W J	1	EA
R511	CRD20TJ152T	RES , CARBON	1.5K OHM 1/5W J	1	EA
R512	CRD20TJ152T	RES , CARBON	1.5K OHM 1/5W J	1	EA
R513	CRD20TJ152T	RES , CARBON	1.5K OHM 1/5W J	1	EA
R514	CRD20TJ152T	RES , CARBON	1.5K OHM 1/5W J	1	EA
R515	CRD20TJ152T	RES , CARBON	1.5K OHM 1/5W J	1	EA
R516	CRD20TJ152T	RES , CARBON	1.5K OHM 1/5W J	1	EA
R517	CRD20TJ152T	RES , CARBON	1.5K OHM 1/5W J	1	EA
R518	CRD20TJ152T	RES , CARBON	1.5K OHM 1/5W J	1	EA
R519	CRD20TJ152T	RES , CARBON	1.5K OHM 1/5W J	1	EA
R520	CRD20TJ152T	RES , CARBON	1.5K OHM 1/5W J	1	EA
R521	CRD20TJ471T	RES , CARBON	470 OHM 1/5W J	1	EA
R522	CRD20TJ471T	RES , CARBON	470 OHM 1/5W J	1	EA
R523	CRD20TJ471T	RES , CARBON	470 OHM 1/5W J	1	EA
R524	CRD20TJ471T	RES , CARBON	470 OHM 1/5W J	1	EA
R525	CRD20TJ471T	RES , CARBON	470 OHM 1/5W J	1	EA
R531	CRD20TJ221T	RES , CARBON	220 OHM 1/5W J	1	EA
R532	CRD20TJ221T	RES , CARBON	220 OHM 1/5W J	1	EA

Ref. Designator	Part Number	Description		Qty	
MAIN PCB (CUP11579W)					
R533	CRD20TJ221T	RES , CARBON	220 OHM 1/5W J	1	EA
R534	CRD20TJ221T	RES , CARBON	220 OHM 1/5W J	1	EA
R535	CRD20TJ221T	RES , CARBON	220 OHM 1/5W J	1	EA
R536	CRD20TJ221T	RES , CARBON	220 OHM 1/5W J	1	EA
R537	CRD20TJ221T	RES , CARBON	220 OHM 1/5W J	1	EA
R538	CRD20TJ221T	RES , CARBON	220 OHM 1/5W J	1	EA
R539	CRD20TJ221T	RES , CARBON	220 OHM 1/5W J	1	EA
R540	CRD20TJ221T	RES , CARBON	220 OHM 1/5W J	1	EA
R541	CRD20TJ271T	RES , CARBON	270 OHM 1/5W J	1	EA
R542	CRD20TJ271T	RES , CARBON	270 OHM 1/5W J	1	EA
R543	CRD20TJ271T	RES , CARBON	270 OHM 1/5W J	1	EA
R544	CRD20TJ271T	RES , CARBON	270 OHM 1/5W J	1	EA
R545	CRD20TJ271T	RES , CARBON	270 OHM 1/5W J	1	EA
R556	CRD20TJ273T	RES , CARBON	27K OHM 1/5W J	1	EA
R557	CRD20TJ273T	RES , CARBON	27K OHM 1/5W J	1	EA
R558	CRD20TJ273T	RES , CARBON	27K OHM 1/5W J	1	EA
R559	CRD20TJ273T	RES , CARBON	27K OHM 1/5W J	1	EA
R560	CRD20TJ273T	RES , CARBON	27K OHM 1/5W J	1	EA
R561	CRD20TJ162T	RES , CARBON	1.6K OHM 1/5W J	1	EA
R562	CRD20TJ162T	RES , CARBON	1.6K OHM 1/5W J	1	EA
R564	CRD20TJ162T	RES , CARBON	1.6K OHM 1/5W J	1	EA
R566	CRD20TJ561T	RES , CARBON	560 OHM 1/5W J	1	EA
R567	CRD20TJ561T	RES , CARBON	560 OHM 1/5W J	1	EA
R568	CRD20TJ561T	RES , CARBON	560 OHM 1/5W J	1	EA
R569	CRD20TJ561T	RES , CARBON	560 OHM 1/5W J	1	EA
R570	CRD20TJ561T	RES , CARBON	560 OHM 1/5W J	1	EA
R571	CRD20TJ561T	RES , CARBON	560 OHM 1/5W J	1	EA
R572	CRD20TJ561T	RES , CARBON	560 OHM 1/5W J	1	EA
R573	CRD20TJ561T	RES , CARBON	560 OHM 1/5W J	1	EA
R574	CRD20TJ561T	RES , CARBON	560 OHM 1/5W J	1	EA
R575	CRD20TJ561T	RES , CARBON	560 OHM 1/5W J	1	EA
R576	CRD20TJ100T	RES , CARBON	10 OHM 1/5W J	1	EA
R577	CRD20TJ100T	RES , CARBON	10 OHM 1/5W J	1	EA
R578	CRD20TJ100T	RES , CARBON	10 OHM 1/5W J	1	EA
R579	CRD20TJ100T	RES , CARBON	10 OHM 1/5W J	1	EA
R580	CRD20TJ100T	RES , CARBON	10 OHM 1/5W J	1	EA
R581	CRD20TJ561T	RES , CARBON	560 OHM 1/5W J	1	EA
R582	CRD20TJ561T	RES , CARBON	560 OHM 1/5W J	1	EA
R583	CRD20TJ561T	RES , CARBON	560 OHM 1/5W J	1	EA
R584	CRD20TJ561T	RES , CARBON	560 OHM 1/5W J	1	EA
R585	CRD20TJ561T	RES , CARBON	560 OHM 1/5W J	1	EA
R586	CRD20TJ561T	RES , CARBON	560 OHM 1/5W J	1	EA
R587	CRD20TJ561T	RES , CARBON	560 OHM 1/5W J	1	EA
R588	CRD20TJ561T	RES , CARBON	560 OHM 1/5W J	1	EA
R589	CRD20TJ561T	RES , CARBON	560 OHM 1/5W J	1	EA
R590	CRD20TJ561T	RES , CARBON	560 OHM 1/5W J	1	EA
R591	CRD20TJ561T	RES , CARBON	560 OHM 1/5W J	1	EA
R592	CRD20TJ561T	RES , CARBON	560 OHM 1/5W J	1	EA
R593	CRD20TJ561T	RES , CARBON	560 OHM 1/5W J	1	EA
R594	CRD20TJ561T	RES , CARBON	560 OHM 1/5W J	1	EA
R595	CRD20TJ561T	RES , CARBON	560 OHM 1/5W J	1	EA
R596	CRD20TJ561T	RES , CARBON	560 OHM 1/5W J	1	EA
R597	CRD20TJ561T	RES , CARBON	560 OHM 1/5W J	1	EA
R598	CRD20TJ561T	RES , CARBON	560 OHM 1/5W J	1	EA
R599	CRD20TJ561T	RES , CARBON	560 OHM 1/5W J	1	EA
R600	CRD20TJ561T	RES , CARBON	560 OHM 1/5W J	1	EA
R601	CRD20TJ223T	RES , CARBON	22K OHM 1/5W J	1	EA
R602	CRD20TJ223T	RES , CARBON	22K OHM 1/5W J	1	EA
R603	CRD20TJ223T	RES , CARBON	22K OHM 1/5W J	1	EA
R604	CRD20TJ223T	RES , CARBON	22K OHM 1/5W J	1	EA
R605	CRD20TJ223T	RES , CARBON	22K OHM 1/5W J	1	EA

Ref. Designator	Part Number	Description		Qty	
MAIN PCB (CUP11579W)					
R606	CRD20TJ223T	RES , CARBON	22K OHM 1/5W J	1	EA
R607	CRD20TJ223T	RES , CARBON	22K OHM 1/5W J	1	EA
R608	CRD20TJ223T	RES , CARBON	22K OHM 1/5W J	1	EA
R609	CRD20TJ223T	RES , CARBON	22K OHM 1/5W J	1	EA
R610	CRD20TJ223T	RES , CARBON	22K OHM 1/5W J	1	EA
R611	CRD20TJ100T	RES , CARBON	10 OHM 1/5W J	1	EA
R612	CRD20TJ100T	RES , CARBON	10 OHM 1/5W J	1	EA
R631	KRD25FJ180T	RES , CARBON	18 OHM 1/4W	1	EA
R632	KRD25FJ180T	RES , CARBON	18 OHM 1/4W	1	EA
R633	KRD25FJ180T	RES , CARBON	18 OHM 1/4W	1	EA
R634	KRD25FJ180T	RES , CARBON	18 OHM 1/4W	1	EA
R635	KRD25FJ180T	RES , CARBON	18 OHM 1/4W	1	EA
R636	KRD25FJ180T	RES , CARBON	18 OHM 1/4W	1	EA
R637	KRD25FJ180T	RES , CARBON	18 OHM 1/4W	1	EA
R638	KRD25FJ180T	RES , CARBON	18 OHM 1/4W	1	EA
R639	KRD25FJ180T	RES , CARBON	18 OHM 1/4W	1	EA
R640	KRD25FJ180T	RES , CARBON	18 OHM 1/4W	1	EA
R646	KRD25FJ3R3T	RES , CARBON	3.3 OHM 1/4W	1	EA
R647	KRD25FJ3R3T	RES , CARBON	3.3 OHM 1/4W	1	EA
R648	KRD25FJ3R3T	RES , CARBON	3.3 OHM 1/4W	1	EA
R649	KRD25FJ3R3T	RES , CARBON	3.3 OHM 1/4W	1	EA
R650	KRD25FJ3R3T	RES , CARBON	3.3 OHM 1/4W	1	EA
R651	KRD25FJ3R3T	RES , CARBON	3.3 OHM 1/4W	1	EA
R652	KRD25FJ3R3T	RES , CARBON	3.3 OHM 1/4W	1	EA
R653	KRD25FJ3R3T	RES , CARBON	3.3 OHM 1/4W	1	EA
R654	KRD25FJ3R3T	RES , CARBON	3.3 OHM 1/4W	1	EA
R655	KRD25FJ3R3T	RES , CARBON	3.3 OHM 1/4W	1	EA
R666	CRD25TJ470T	RES , CARBON	47 OHM 1/4W	1	EA
R667	CRD25TJ470T	RES , CARBON	47 OHM 1/4W	1	EA
R668	CRD25TJ470T	RES , CARBON	47 OHM 1/4W	1	EA
R669	CRD25TJ470T	RES , CARBON	47 OHM 1/4W	1	EA
R670	CRD25TJ470T	RES , CARBON	47 OHM 1/4W	1	EA
R671	CRD20TJ911T	RES , CARBON	910 OHM 1/5W J	1	EA
R672	CRD20TJ911T	RES , CARBON	910 OHM 1/5W J	1	EA
R673	CRD20TJ911T	RES , CARBON	910 OHM 1/5W J	1	EA
R674	CRD20TJ911T	RES , CARBON	910 OHM 1/5W J	1	EA
R675	CRD20TJ911T	RES , CARBON	910 OHM 1/5W J	1	EA
R676	CRD20TJ182T	RES , CARBON	1.8K OHM 1/5W J	1	EA
R677	CRD20TJ182T	RES , CARBON	1.8K OHM 1/5W J	1	EA
R678	CRD20TJ182T	RES , CARBON	1.8K OHM 1/5W J	1	EA
R679	CRD20TJ182T	RES , CARBON	1.8K OHM 1/5W J	1	EA
R680	CRD20TJ182T	RES , CARBON	1.8K OHM 1/5W J	1	EA
R681	CRD20TJ562T	RES , CARBON	5.6K OHM 1/5W J	1	EA
R682	CRD20TJ562T	RES , CARBON	5.6K OHM 1/5W J	1	EA
R683	CRD20TJ562T	RES , CARBON	5.6K OHM 1/5W J	1	EA
R684	CRD20TJ562T	RES , CARBON	5.6K OHM 1/5W J	1	EA
R685	CRD20TJ562T	RES , CARBON	5.6K OHM 1/5W J	1	EA
R686	CRD20TJ103T	RES , CARBON	10K OHM 1/5W J	1	EA
R687	CRD20TJ103T	RES , CARBON	10K OHM 1/5W J	1	EA
R688	CRD20TJ103T	RES , CARBON	10K OHM 1/5W J	1	EA
R689	CRD20TJ103T	RES , CARBON	10K OHM 1/5W J	1	EA
R690	CRD20TJ103T	RES , CARBON	10K OHM 1/5W J	1	EA
R696	CRD25TJ470T	RES , CARBON	47 OHM 1/4W	1	EA
R697	CRD25TJ470T	RES , CARBON	47 OHM 1/4W	1	EA
R698	CRD25TJ470T	RES , CARBON	47 OHM 1/4W	1	EA
R699	CRD25TJ470T	RES , CARBON	47 OHM 1/4W	1	EA
R700	CRD25TJ470T	RES , CARBON	47 OHM 1/4W	1	EA
R701	CRD20TJ821T	RES , CARBON	820 OHM 1/5W J	1	EA
R702	CRD20TJ821T	RES , CARBON	820 OHM 1/5W J	1	EA
R703	CRD20TJ821T	RES , CARBON	820 OHM 1/5W J	1	EA
R704	CRD20TJ821T	RES , CARBON	820 OHM 1/5W J	1	EA

Ref. Designator	Part Number	Description		Qty	
MAIN PCB (CUP11579W)					
R705	CRD20TJ821T	RES , CARBON	820 OHM 1/5W J	1	EA
R706	CRD20TJ821T	RES , CARBON	820 OHM 1/5W J	1	EA
R707	CRD20TJ821T	RES , CARBON	820 OHM 1/5W J	1	EA
R708	CRD20TJ821T	RES , CARBON	820 OHM 1/5W J	1	EA
R711	CRD20TJ472T	RES , CARBON	4.7K OHM 1/5W J	1	EA
R712	CRD20TJ472T	RES , CARBON	4.7K OHM 1/5W J	1	EA
R713	CRD20TJ472T	RES , CARBON	4.7K OHM 1/5W J	1	EA
R714	CRD20TJ472T	RES , CARBON	4.7K OHM 1/5W J	1	EA
R715	CRD20TJ472T	RES , CARBON	4.7K OHM 1/5W J	1	EA
R716	CRD20TJ472T	RES , CARBON	4.7K OHM 1/5W J	1	EA
R717	CRD20TJ472T	RES , CARBON	4.7K OHM 1/5W J	1	EA
R718	CRD20TJ472T	RES , CARBON	4.7K OHM 1/5W J	1	EA
R721	CRD20TJ104T	RES , CARBON	100K OHM 1/5W J	1	EA
R722	CRD20TJ104T	RES , CARBON	100K OHM 1/5W J	1	EA
R723	CRD20TJ104T	RES , CARBON	100K OHM 1/5W J	1	EA
R724	CRD20TJ104T	RES , CARBON	100K OHM 1/5W J	1	EA
R725	CRD20TJ104T	RES , CARBON	100K OHM 1/5W J	1	EA
R726	CRD20TJ104T	RES , CARBON	100K OHM 1/5W J	1	EA
R727	CRD20TJ104T	RES , CARBON	100K OHM 1/5W J	1	EA
R728	CRD20TJ104T	RES , CARBON	100K OHM 1/5W J	1	EA
R771	CRD20TJ750T	RES , CARBON	75 OHM 1/5W J	1	EA
R772	CRD20TJ750T	RES , CARBON	75 OHM 1/5W J	1	EA
R773	CRD20TJ750T	RES , CARBON	75 OHM 1/5W J	1	EA
R774	CRD20TJ750T	RES , CARBON	75 OHM 1/5W J	1	EA
R775	CRD20TJ750T	RES , CARBON	75 OHM 1/5W J	1	EA
R776	CRD20TJ750T	RES , CARBON	75 OHM 1/5W J	1	EA
R777	CRD20TJ750T	RES , CARBON	75 OHM 1/5W J	1	EA
R781	CRD20TJ750T	RES , CARBON	75 OHM 1/5W J	1	EA
R782	CRD20TJ750T	RES , CARBON	75 OHM 1/5W J	1	EA
R783	CRD20TJ750T	RES , CARBON	75 OHM 1/5W J	1	EA
R784	CRD20TJ750T	RES , CARBON	75 OHM 1/5W J	1	EA
R785	CRD20TJ750T	RES , CARBON	75 OHM 1/5W J	1	EA
R786	CRD20TJ750T	RES , CARBON	75 OHM 1/5W J	1	EA
R787	CRD20TJ750T	RES , CARBON	75 OHM 1/5W J	1	EA
R801	CRD20TJ103T	RES , CARBON	10K OHM 1/5W J	1	EA
R802	CRD20TJ103T	RES , CARBON	10K OHM 1/5W J	1	EA
R803	CRD20TJ562T	RES , CARBON	5.6K OHM 1/5W J	1	EA
R804	CRD20TJ562T	RES , CARBON	5.6K OHM 1/5W J	1	EA
R805	CRD20TJ911T	RES , CARBON	910 OHM 1/5W J	1	EA
R807	CRD20TJ911T	RES , CARBON	910 OHM 1/5W J	1	EA
R808	CRD20TJ182T	RES , CARBON	1.8K OHM 1/5W J	1	EA
R809	CRD20TJ182T	RES , CARBON	1.8K OHM 1/5W J	1	EA
R812	CRD25TJ470T	RES , CARBON	47 OHM 1/4W	1	EA
R813	CRD25TJ470T	RES , CARBON	47 OHM 1/4W	1	EA
R814	CRD25TJ470T	RES , CARBON	47 OHM 1/4W	1	EA
R815	CRD25TJ470T	RES , CARBON	47 OHM 1/4W	1	EA
R817	KRD25FJ3R3T	RES , CARBON	3.3 OHM 1/4W	1	EA
R818	KRD25FJ3R3T	RES , CARBON	3.3 OHM 1/4W	1	EA
R819	KRD25FJ3R3T	RES , CARBON	3.3 OHM 1/4W	1	EA
R820	KRD25FJ3R3T	RES , CARBON	3.3 OHM 1/4W	1	EA
R821	KRD25FJ180T	RES , CARBON	18 OHM 1/4W	1	EA
R822	KRD25FJ180T	RES , CARBON	18 OHM 1/4W	1	EA
R823	KRD25FJ180T	RES , CARBON	18 OHM 1/4W	1	EA
R824	KRD25FJ180T	RES , CARBON	18 OHM 1/4W	1	EA
R830	CRD20TJ223T	RES , CARBON	22K OHM 1/5W J	1	EA
R831	CRD20TJ223T	RES , CARBON	22K OHM 1/5W J	1	EA
R832	CRD20TJ223T	RES , CARBON	22K OHM 1/5W J	1	EA
R833	CRD20TJ223T	RES , CARBON	22K OHM 1/5W J	1	EA
R834	CRD20TJ561T	RES , CARBON	560 OHM 1/5W J	1	EA
R835	CRD20TJ561T	RES , CARBON	560 OHM 1/5W J	1	EA
R836	CRD20TJ561T	RES , CARBON	560 OHM 1/5W J	1	EA

Ref. Designator	Part Number	Description		Qty	
MAIN PCB (CUP11579W)					
R837	CRD20TJ561T	RES , CARBON	560 OHM 1/5W J	1	EA
R838	CRD20TJ561T	RES , CARBON	560 OHM 1/5W J	1	EA
R839	CRD20TJ561T	RES , CARBON	560 OHM 1/5W J	1	EA
R840	CRD20TJ561T	RES , CARBON	560 OHM 1/5W J	1	EA
R841	CRD20TJ561T	RES , CARBON	560 OHM 1/5W J	1	EA
R842	CRD20TJ561T	RES , CARBON	560 OHM 1/5W J	1	EA
R843	CRD20TJ561T	RES , CARBON	560 OHM 1/5W J	1	EA
R844	CRD20TJ561T	RES , CARBON	560 OHM 1/5W J	1	EA
R845	CRD20TJ561T	RES , CARBON	560 OHM 1/5W J	1	EA
R848	CRD20TJ273T	RES , CARBON	27K OHM 1/5W J	1	EA
R849	CRD20TJ273T	RES , CARBON	27K OHM 1/5W J	1	EA
R850	CRD20TJ162T	RES , CARBON	1.6K OHM 1/5W J	1	EA
R851	CRD20TJ162T	RES , CARBON	1.6K OHM 1/5W J	1	EA
R852	CRD20TJ152T	RES , CARBON	1.5K OHM 1/5W J	1	EA
R853	CRD20TJ152T	RES , CARBON	1.5K OHM 1/5W J	1	EA
R854	CRD20TJ152T	RES , CARBON	1.5K OHM 1/5W J	1	EA
R855	CRD20TJ152T	RES , CARBON	1.5K OHM 1/5W J	1	EA
R856	CRD20TJ221T	RES , CARBON	220 OHM 1/5W J	1	EA
R857	CRD20TJ221T	RES , CARBON	220 OHM 1/5W J	1	EA
R858	CRD20TJ221T	RES , CARBON	220 OHM 1/5W J	1	EA
R859	CRD20TJ221T	RES , CARBON	220 OHM 1/5W J	1	EA
R860	CRD20TJ271T	RES , CARBON	270 OHM 1/5W J	1	EA
R861	CRD20TJ271T	RES , CARBON	270 OHM 1/5W J	1	EA
R862	CRD20TJ333T	RES , CARBON	33K OHM 1/5W J	1	EA
R863	CRD20TJ333T	RES , CARBON	33K OHM 1/5W J	1	EA
R864	CRD20TJ331T	RES , CARBON	330 OHM 1/5W J	1	EA
R865	CRD20TJ331T	RES , CARBON	330 OHM 1/5W J	1	EA
R866	CRD20TJ472T	RES , CARBON	4.7K OHM 1/5W J	1	EA
R867	CRD20TJ472T	RES , CARBON	4.7K OHM 1/5W J	1	EA
R868	CRD20TJ473T	RES , CARBON	47K OHM 1/5W J	1	EA
R869	CRD20TJ473T	RES , CARBON	47K OHM 1/5W J	1	EA
R870	CRD20TJ433T	RES , CARBON	43K OHM 1/5W J	1	EA
R871	CRD20TJ433T	RES , CARBON	43K OHM 1/5W J	1	EA
R872	CRD20TJ471T	RES , CARBON	470 OHM 1/5W J	1	EA
R873	CRD20TJ471T	RES , CARBON	470 OHM 1/5W J	1	EA
R900	CRD20TJ103T	RES , CARBON	10K OHM 1/5W J	1	EA
R901	CRD25TJ393T	RES , CARBON	39K OHM 1/4W J	1	EA
R902	CRD25TJ393T	RES , CARBON	39K OHM 1/4W J	1	EA
R903	CRD25TJ393T	RES , CARBON	39K OHM 1/4W J	1	EA
R906	CRD25TJ393T	RES , CARBON	39K OHM 1/4W J	1	EA
R907	CRD20TJ103T	RES , CARBON	10K OHM 1/5W J	1	EA
R908	CRD20TJ105T	RES , CARBON	1M OHM 1/5W J	1	EA
R909	CRD20TJ682T	RES , CARBON	6.8K OHM 1/5W J	1	EA
R910	CRD20TJ105T	RES , CARBON	1M OHM 1/5W J	1	EA
R911	CRD25TJ680T	RES , CARBON	68 OHM 1/4W J	1	EA
R917	CRD25TJ393T	RES , CARBON	39K OHM 1/4W J	1	EA
R918	CRD25TJ393T	RES , CARBON	39K OHM 1/4W J	1	EA
R919	CRD25TJ393T	RES , CARBON	39K OHM 1/4W J	1	EA
R920	CRD25TJ393T	RES , CARBON	39K OHM 1/4W J	1	EA
R921	KRD25FJ180T	RES , CARBON	18 OHM 1/4W	1	EA
R922	CRD25TJ470T	RES , CARBON	47 OHM 1/4W	1	EA
R924	CRD20TJ473T	RES , CARBON	47K OHM 1/5W J	1	EA
R925	CRD20TJ473T	RES , CARBON	47K OHM 1/5W J	1	EA
R926	CRD20TJ473T	RES , CARBON	47K OHM 1/5W J	1	EA
R927	CRD20TJ473T	RES , CARBON	47K OHM 1/5W J	1	EA
R928	CRD20TJ222T	RES , CARBON	2.2K OHM 1/5W J	1	EA
R929	CRD20TJ222T	RES , CARBON	2.2K OHM 1/5W J	1	EA
R930	CRD20TJ222T	RES , CARBON	2.2K OHM 1/5W J	1	EA
R931	CRD20TJ222T	RES , CARBON	2.2K OHM 1/5W J	1	EA
R932	CRD20TJ103T	RES , CARBON	10K OHM 1/5W J	1	EA
R933	CRD20TJ472T	RES , CARBON	4.7K OHM 1/5W J	1	EA

Ref. Designator	Part Number	Description		Qty	
MAIN PCB (CUP11579W)					
R934	CRD20TJ104T	RES , CARBON	100K OHM 1/5W J	1	EA
R935	CRD20TJ154T	RES , CARBON	150K OHM 1/5W J	1	EA
R936	CRD20TJ184T	RES , CARBON	180K OHM 1/5W J	1	EA
R939	CRD20TJ472T	RES , CARBON	4.7K OHM 1/5W J	1	EA
R940	CRD20TJ152T	RES , CARBON	1.5K OHM 1/5W J	1	EA
R941	CRD20TJ223T	RES , CARBON	22K OHM 1/5W J	1	EA
R942	CRD20TJ223T	RES , CARBON	22K OHM 1/5W J	1	EA
R943	CRD20TJ223T	RES , CARBON	22K OHM 1/5W J	1	EA
R944	CRD25TJ223T	RES , CARBON	22K OHM 1/4W J	1	EA
R945	CRD20TJ223T	RES , CARBON	22K OHM 1/5W J	1	EA
R946	CRD25TJ223T	RES , CARBON	22K OHM 1/4W J	1	EA
R947	CRD20TJ223T	RES , CARBON	22K OHM 1/5W J	1	EA
R953	CRD20TJ223T	RES , CARBON	22K OHM 1/5W J	1	EA
R954	CRD20TJ223T	RES , CARBON	22K OHM 1/5W J	1	EA
R955	CRD20TJ203T	RES , CARBON	20K OHM 1/5W J	1	EA
R956	CRD20TJ394T	RES , CARBON	390K OHM 1/5W J	1	EA
R957	CRD20TJ153T	RES , CARBON	15K OHM 1/5W J	1	EA
R958	CRD20TJ563T	RES , CARBON	56K OHM 1/5W J	1	EA
R960	CRD20TJ222T	RES , CARBON	2.2K OHM 1/5W J	1	EA
R961	CRD20TJ331T	RES , CARBON	330 OHM 1/5W J	1	EA
R962	CRD20TJ273T	RES , CARBON	27K OHM 1/5W J	1	EA
R963	CRD20TJ105T	RES , CARBON	1M OHM 1/5W J	1	EA
R964	CRD20TJ105T	RES , CARBON	1M OHM 1/5W J	1	EA
R966	CRD20TJ472T	RES , CARBON	4.7K OHM 1/5W J	1	EA
R969	CRD20TJ472T	RES , CARBON	4.7K OHM 1/5W J	1	EA
R970	CRD20TJ472T	RES , CARBON	4.7K OHM 1/5W J	1	EA
R971	CRD20TJ472T	RES , CARBON	4.7K OHM 1/5W J	1	EA
R972	CRD20TJ472T	RES , CARBON	4.7K OHM 1/5W J	1	EA
R973	CRD20TJ472T	RES , CARBON	4.7K OHM 1/5W J	1	EA
R974	CRD20TJ331T	RES , CARBON	330 OHM 1/5W J	1	EA
R975	CRD20TJ331T	RES , CARBON	330 OHM 1/5W J	1	EA
R976	CRD20TJ331T	RES , CARBON	330 OHM 1/5W J	1	EA
R977	CRD20TJ331T	RES , CARBON	330 OHM 1/5W J	1	EA
R978	CRD20TJ331T	RES , CARBON	330 OHM 1/5W J	1	EA
R979	CRD20TJ473T	RES , CARBON	47K OHM 1/5W J	1	EA
R980	CRD20TJ473T	RES , CARBON	47K OHM 1/5W J	1	EA
R981	CRD20TJ473T	RES , CARBON	47K OHM 1/5W J	1	EA
R982	CRD20TJ473T	RES , CARBON	47K OHM 1/5W J	1	EA
R983	CRD20TJ473T	RES , CARBON	47K OHM 1/5W J	1	EA
R986	CRD20TJ102T	RES , CARBON	1K OHM 1/5W J	1	EA
R987	CRD20TJ561T	RES , CARBON	560 OHM 1/5W J	1	EA
R988	CRD20TJ562T	RES , CARBON	5.6K OHM 1/5W J	1	EA
R991	CRD20TJ822T	RES , CARBON	8.2K OHM 1/5W J	1	EA
R992	CRD20TJ562T	RES , CARBON	5.6K OHM 1/5W J	1	EA
R998	CRD20TJ103T	RES , CARBON	10K OHM 1/5W J	1	EA
R563	CRD20TJ162T	RES , CARBON	1.6K OHM 1/5W J	1	EA
R565	CRD20TJ162T	RES , CARBON	1.6K OHM 1/5W J	1	EA
R656	CRF5EKR27HX2K	RES , CEMENT	0.27ohm X 2	1	EA
R657	CRF5EKR27HX2K	RES , CEMENT	0.27ohm X 2	1	EA
R658	CRF5EKR27HX2K	RES , CEMENT	0.27ohm X 2	1	EA
R659	CRF5EKR27HX2K	RES , CEMENT	0.27ohm X 2	1	EA
R660	CRF5EKR27HX2K	RES , CEMENT	0.27ohm X 2	1	EA
R810	CRF5EKR27HX2K	RES , CEMENT	0.27ohm X 2	1	EA
R811	CRF5EKR27HX2K	RES , CEMENT	0.27ohm X 2	1	EA
R904	HRDERC12UGK335T	RES , CARBONJP	3.3M OHM	1	EA
R905	CRG1ANJ100H	RES , METAL OXIDE FILM	10 OHM	1	EA
R923	CRD25TJ220T	RES , CARBON	22 OHM 1/4W J	1	EA
R959	CRD20TJ223T	RES , CARBON	22K OHM 1/5W J	1	EA
R990	CRG1ANJ100H	RES , METAL OXIDE FILM	10 OHM	1	EA
R993	CRG1ANJ100H	RES , METAL OXIDE FILM	10 OHM	1	EA
R994	CRG1ANJ100H	RES , METAL OXIDE FILM	10 OHM	1	EA

Ref. Designator	Part Number	Description		Qty	
MAIN PCB (CUP11579W)					
R995	CRG1ANJ100H	RES , METAL OXIDE FILM	10 OHM	1	EA
R996	CRG1ANJ100H	RES , METAL OXIDE FILM	10 OHM	1	EA
R997	CRG1ANJ100H	RES , METAL OXIDE FILM	10 OHM	1	EA
R999	CRG1ANJ100H	RES , METAL OXIDE FILM	10 OHM	1	EA
<i>Miscellaneous</i>					
	CMYAVR335	HEAT SINK ASS'Y	ASS'Y	1	EA
	CHD1A012	SCREW , TR	SCREW	21	EA
	CHD1A036FZ	SCREW , SPECIAL	SCREW	4	EA
	CHD3A012	SCREW , TR	SCREW	3	EA
	CMD1A398	BRACKET , PCB	BRACKET	2	EA
	CMD1A417	BRACKET , PCB	BRACKET	2	EA
	CMD1A488	BRACKET , FAN	BRACKET	1	EA
	CMY1A249	HEAT SINK	HEAT SINK	2	EA
	CMY2A205	HEAT SINK,SUB	HEAT SINK	1	EA
	CTB3+10J	SCREW	SCREW	6	EA
	CTB3+8J	SCREW	SCREW	6	EA
	HDMKD1206PTS3	MOTOR , FAN(60X60X25MM)	FAN	1	EA
BN19	CWB3FE03250UP	WIRE ASS'Y	WIRE	1	EA
BN20	CWB3FB43280UP	WIRE ASS'Y	WIRE	1	EA
BN79	CWZAVR230BN79	WIRE ASS'Y (SHIELD)	WIRE	1	EA
BN81	CWB1C902050EN	WIRE ASS'Y	WIRE	1	EA
BN82	CWB1C902050EN	WIRE ASS'Y	WIRE	1	EA
BN83	CWB1C902050EN	WIRE ASS'Y	WIRE	1	EA
BN84	CWB1C902050EN	WIRE ASS'Y	WIRE	1	EA
BN85	CWB1C902050EN	WIRE ASS'Y	WIRE	1	EA
BN86	CWB1C902050EN	WIRE ASS'Y	WIRE	1	EA
BN87	CWB1C902050EN	WIRE ASS'Y	WIRE	1	EA
BN88	CWB2B904070EN	WIRE ASS'Y	WIRE	1	EA
BN97	CWZAVR340BN97	WIRE ASS'Y	WIRE	1	EA
BN98	HJP08GA130ZK	WAFER	WAFER	1	EA
CN61	KJP02GA01ZM	WAFER	WAFER	1	EA
CN62	KJP02GA01ZM	WAFER	WAFER	1	EA
CN63	KJP02GA01ZM	WAFER	WAFER	1	EA
CN64	KJP02GA01ZM	WAFER	WAFER	1	EA
CN65	KJP02GA01ZM	WAFER	WAFER	1	EA
CN66	KJP02GA01ZM	WAFER	WAFER	1	EA
CN67	KJP02GA01ZM	WAFER	WAFER	1	EA
CN80	KJP11GA19ZM	WAFER	WAFER	1	EA
CN89	KJP02GA01ZM	WAFER	WAFER	1	EA
CN91	KJP03GA89ZM	WAFER	WAFER	1	EA
CN92	KJP02GA01ZM	WAFER	WAFER	1	EA
CN94	KJP13GA98ZM	WAFER	WAFER	1	EA
CN95	KJP08GA98ZM	WAFER	WAFER	1	EA
ET01	CMD1A387	BRACKET , PCB	BRACKET	3	EA
ET01	CNE75	PLATE , EARTH	PLATE	1	EA
ET02	CMD1A387	BRACKET , PCB	BRACKET	3	EA
ET03	CNE75	PLATE , EARTH	PLATE	1	EA
JK91	CJJ5R006Z	TERMINAL , SPEAKER	SPEAKER TERMINAL	1	EA
JK92	CJJ5Q012Z	TERMINAL , SPEAKER	SPEAKER TERMINAL	1	EA
JK97	CJJ4P041W	JACK IN/OUT	JACK	1	EA
JK98	CJJ4P042W	JACK IN/OUT	JACK	1	EA
JW90	CWEE212120VV	WIRE ASS'Y	WIRE	1	EA
JW91	CWE8212180VV	WIRE ASS'Y	WIRE	1	EA
JW93	CWE7202110AA	WIRE ASS'Y	WIRE	1	EA
JW98	CWE7202110AA	WIRE ASS'Y	WIRE	1	EA
JW99	CWE8202150AA	WIRE ASS'Y	WIRE	1	EA
L501	CLEY0R5KAK	COIL , SPEAKER	0.5UH K	1	EA
L502	CLEY0R5KAK	COIL , SPEAKER	0.5UH K	1	EA
L503	CLEY0R5KAK	COIL , SPEAKER	0.5UH K	1	EA

Ref. Designator	Part Number	Description		Qty	
MAIN PCB (CUP11579W)					
L504	CLEY0R5KAK	COIL , SPEAKER	0.5UH K	1	EA
L505	CLEY0R5KAK	COIL , SPEAKER	0.5UH K	1	EA
L506	CLEY0R5KAK	COIL , SPEAKER	0.5UH K	1	EA
L507	CLEY0R5KAK	COIL , SPEAKER	0.5UH K	1	EA
RY94	HSL1A008ZE	RELAY	SDT-S-112DMR	1	EA
TH91	KRTP42T7D330B	THERMAL SENSOR , POSISTOR	POSISTOR	1	EA
T902	CLT5J038ZU	TRANS , SUB	SUB TRANS	1	EA
	CTW3+8J	SCREW	SCREW	2	EA
	CUP11817Z	PCB , CONNECTOR	PCB		
	CNVM9011MS071L	AVR 340 TUNER MODULE			

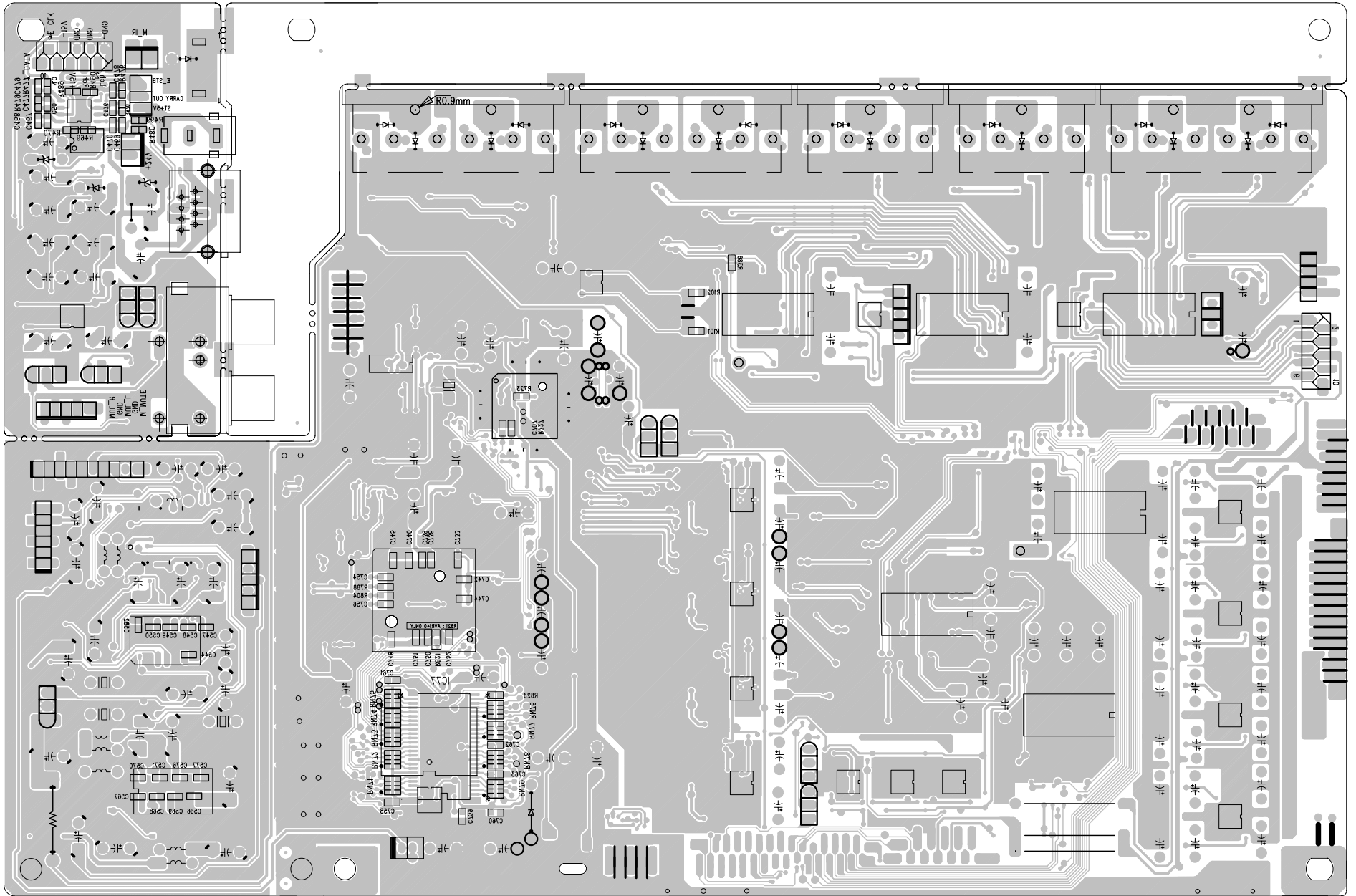

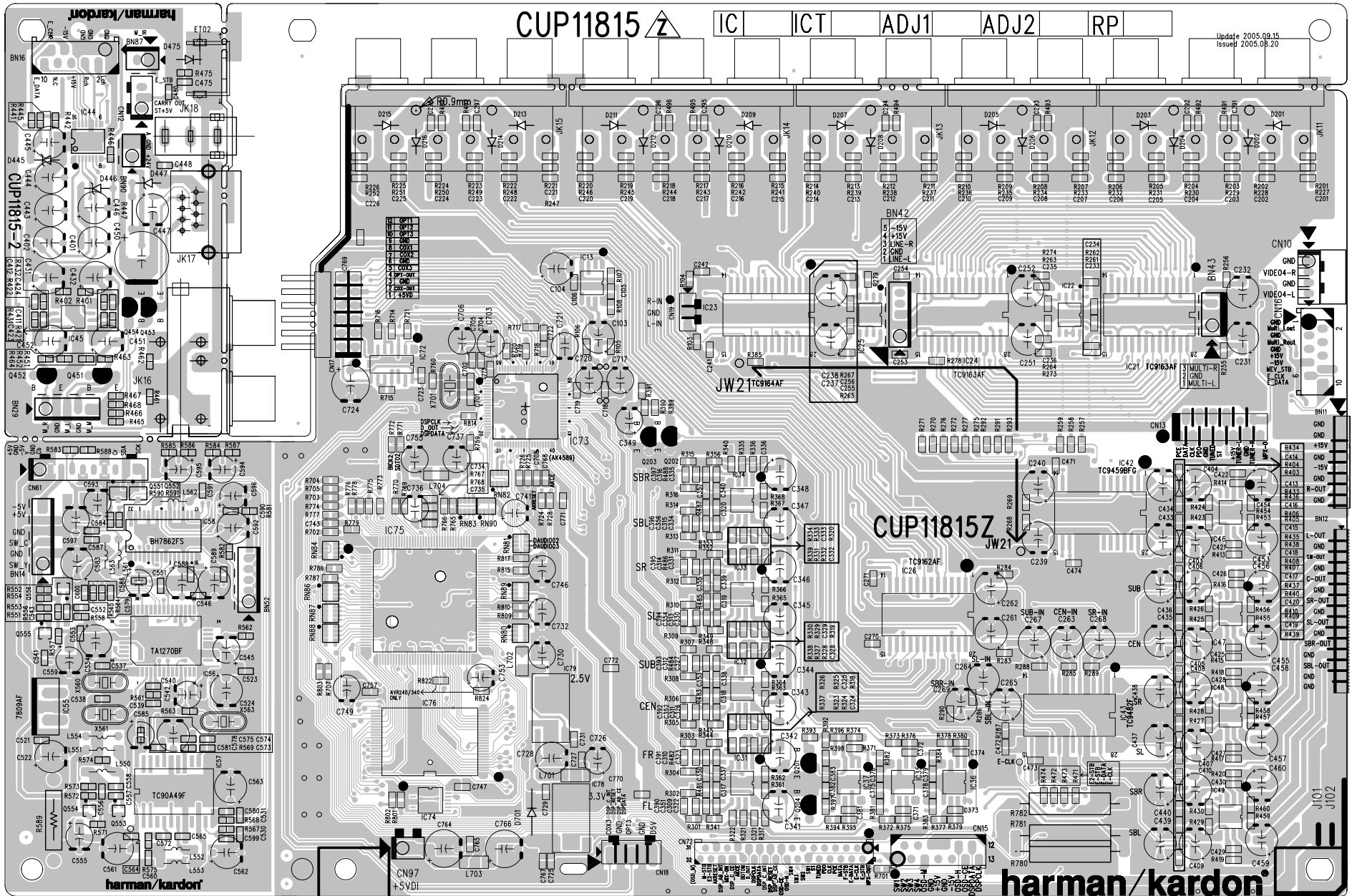

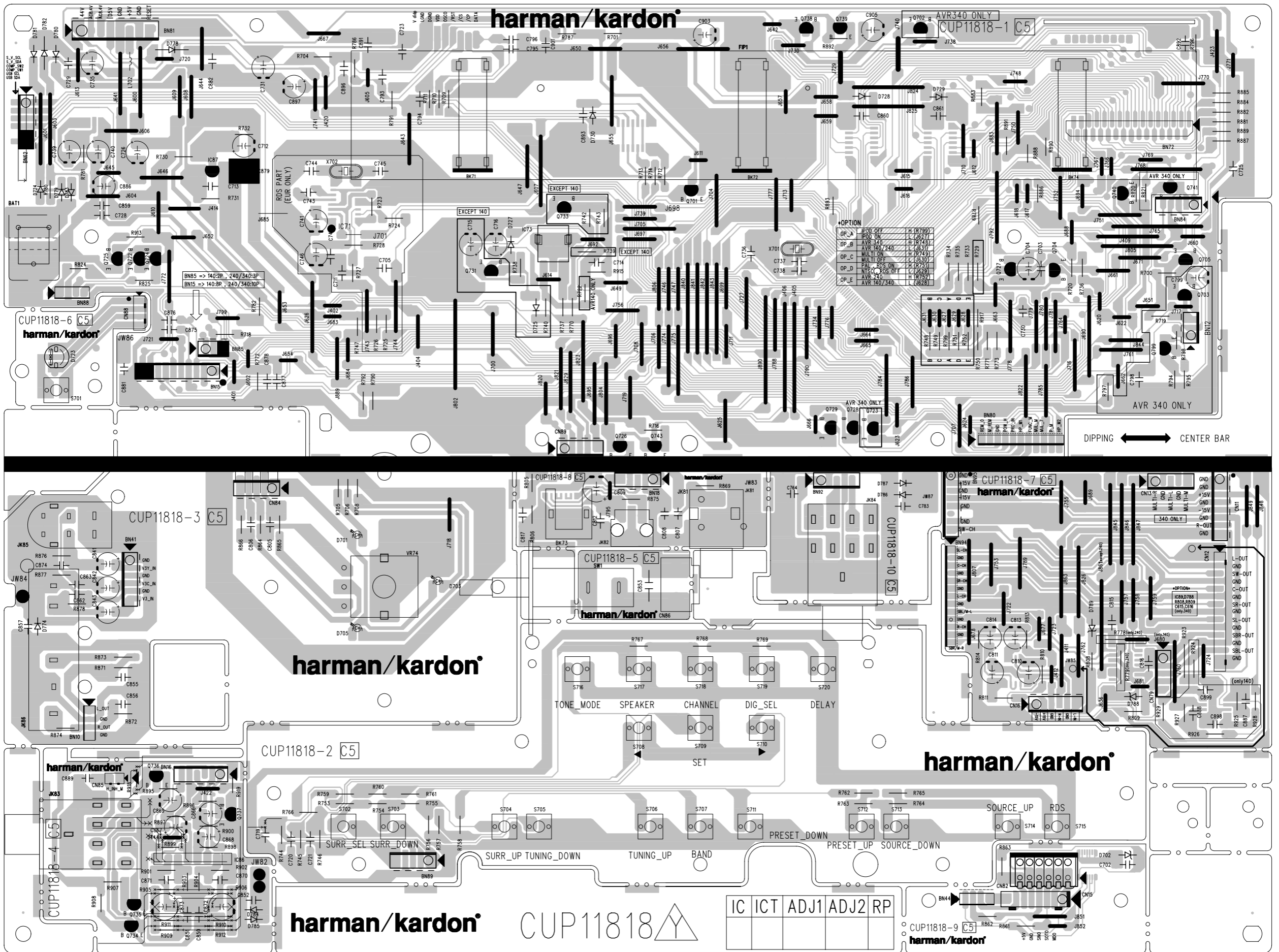

MAIN BOARD 1 (AMP)

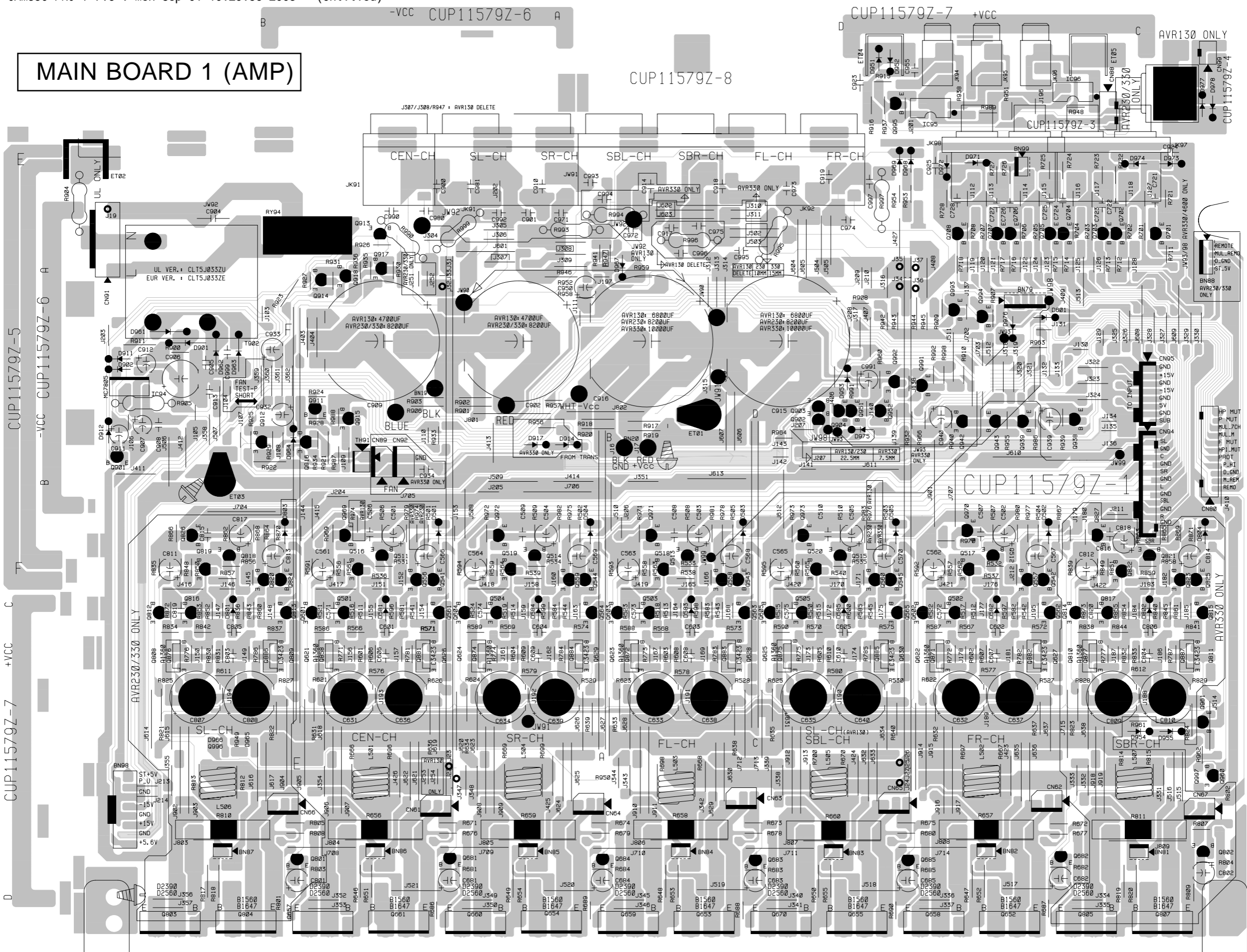

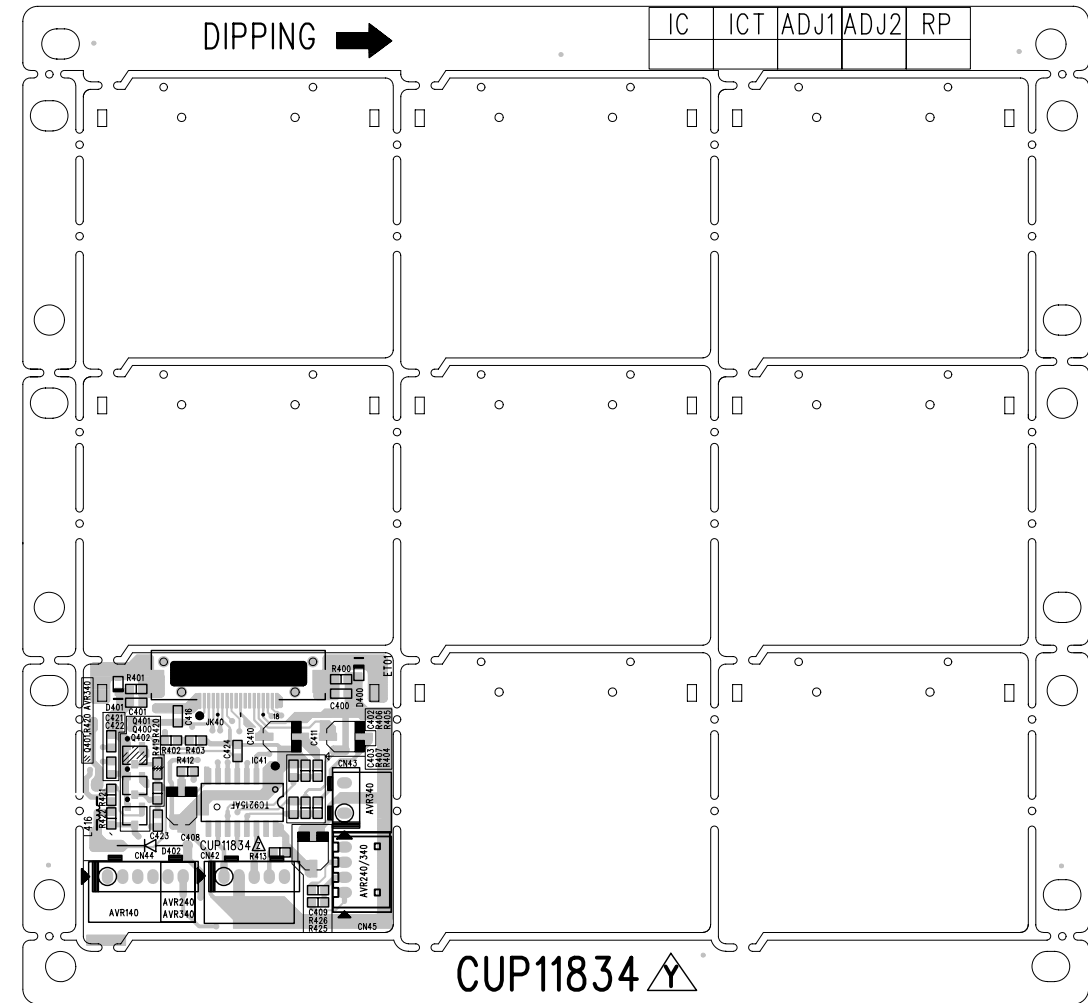
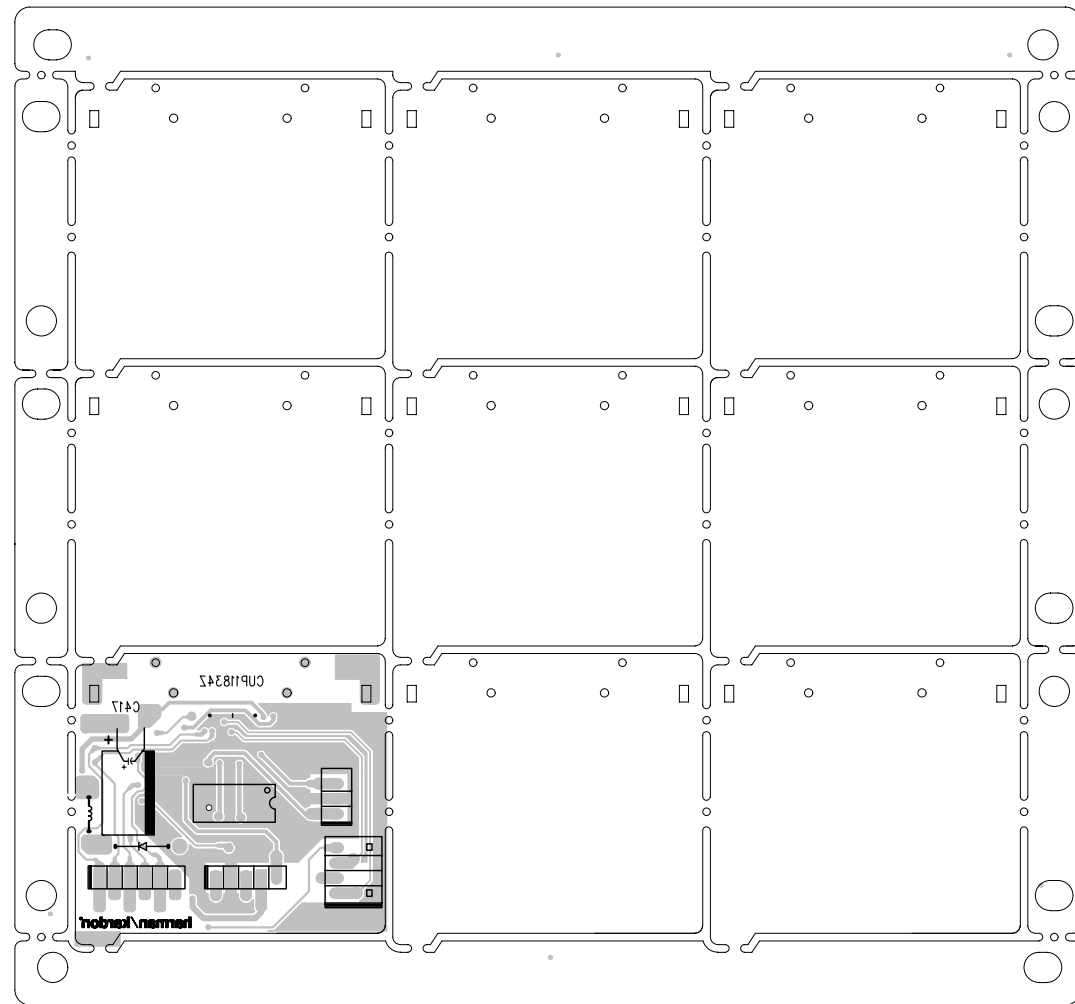



November 1988

Revised November 1999

74AC04 • 74ACT04

Hex Inverter

74ACT04SC : IC52,75,83,84

General Description

The AC/ACT04 contains six inverters.

Features

- I_{CC} reduced by 50% on 74AC only
- Outputs source/sink 24 mA
- ACT04 has TTL-compatible inputs

Ordering Code:

Order Number	Package Number	Package Description
74AC04SC	M14A	14-Lead Small Outline Integrated Circuit (SOIC), JEDEC MS-120, 0.150" Narrow Body
74AC04SJ	M14D	14-Lead Small Outline Package (SOP), EIAJ TYPE II, 5.3mm Wide
74AC04MTC	MTC14	14-Lead Thin Shrink Small Outline Package (TSSOP), JEDEC MO-153, 4.4mm Wide
74AC04PC	N14A	14-Lead Plastic Dual-In-Line Package (PDIP), JEDEC MS-001, 0.300" Wide
74ACT04SC	M14A	14-Lead Small Outline Integrated Circuit (SOIC), JEDEC MS-120, 0.150" Narrow Body
74ACT04MTC	MTC14	14-Lead Thin Shrink Small Outline Package (TSSOP), JEDEC MO-153, 4.4mm Wide
74ACT04PC	N14A	14-Lead Plastic Dual-In-Line Package (PDIP), JEDEC MS-001, 0.300" Wide

Device also available in Tape and Reel. Specify by appending suffix letter "X" to the ordering code. (PC not available in Tape and Reel.)

Logic Symbol

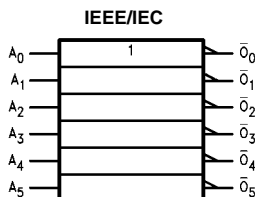

Connection Diagram

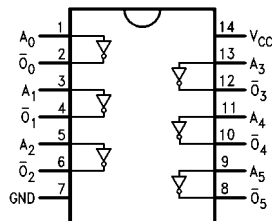

Pin Descriptions

Pin Names	Description
A_n	Inputs
\bar{O}_n	Outputs



M54HCU04
M74HCU04

HEX INVERTER (SINGLE STAGE)

- **HIGH SPEED**
 $t_{PD} = 5 \text{ ns (TYP.) AT } V_{CC} = 5 \text{ V}$
- **LOW POWER DISSIPATION**
 $I_{CC} = 1 \mu\text{A (MAX.) AT } T_A = 25 \text{ }^\circ\text{C}$
- **HIGH NOISE IMMUNITY**
 $V_{NIH} = V_{NIL} = 10 \% V_{CC} \text{ (MIN.)}$
- **OUTPUT DRIVE CAPABILITY**
 10 LSTTL LOADS
- **SYMMETRICAL OUTPUT IMPEDANCE**
 $|I_{OH}| = I_{OL} = 4 \text{ mA (MIN.)}$
- **BALANCED PROPAGATION DELAYS**
 $t_{PLH} = t_{PHL}$
- **WIDE OPERATING VOLTAGE RANGE**
 $V_{CC} \text{ (OPR)} = 2 \text{ V TO } 6 \text{ V}$
- **PIN AND FUNCTION COMPATIBLE WITH**
 54/74LS04

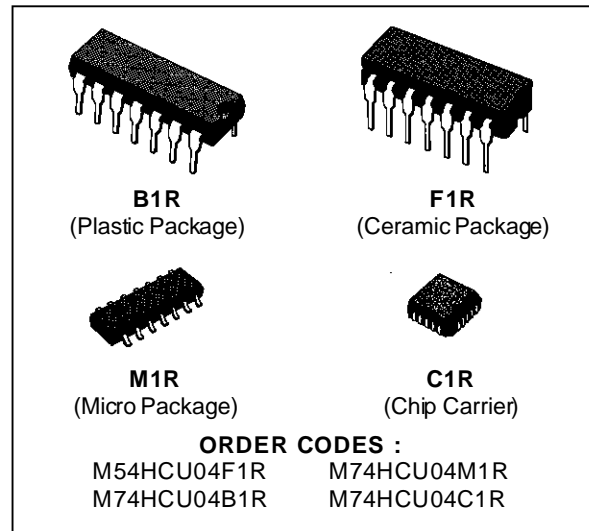

DESCRIPTION

The M54/74HCU04 is a high speed CMOS HEX INVERTER (SINGLE STAGE) fabricated in silicon gate C²MOS technology. It has the same high speed performance of LSTTL combined with true CMOS low power consumption.

As the intrnal circuit is composed of a single stage inverter, it can be used in crystal oscillator.

All inputs are equipped with circuits against static discharge and transient excess voltage.

INPUT AND OUTPUT EQUIVALENT CIRCUIT

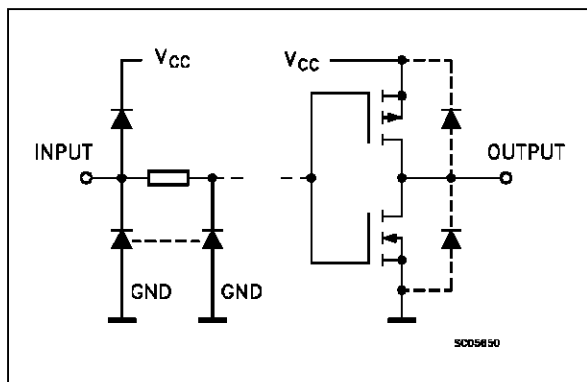

PIN CONNECTIONS (top view)

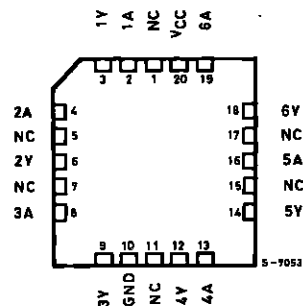
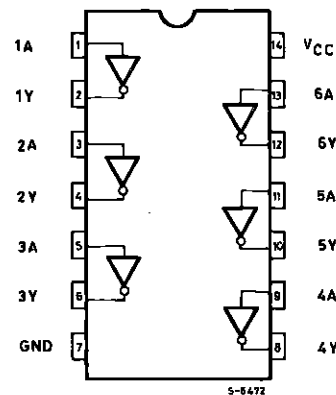

NC =
No Internal
Connection

■ PIN ASSIGNMENT (74HCU04AFN : IC72,76)

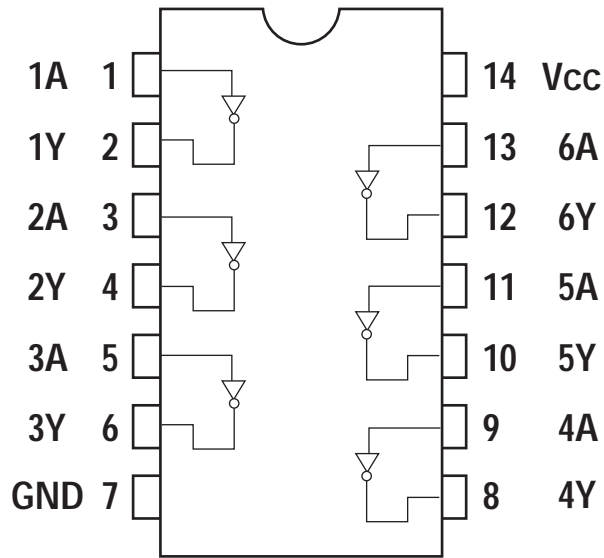

■ LOGIC SYMBOL

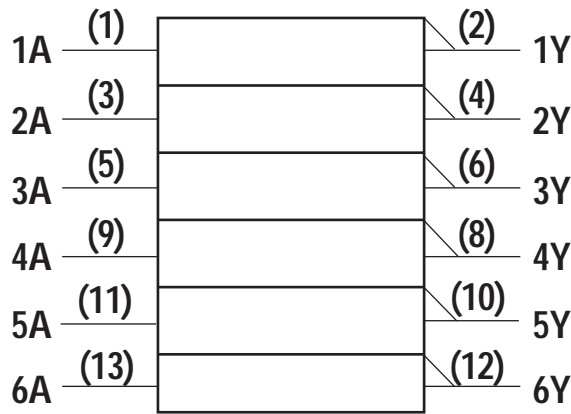

■ TRUTH TABLE

A	Y
L	H
H	L

Video Switch · 75Ω driver · Y/C mix Monolithic IC MM1501 Series

Outline

This IC extends the series of ICs for video/audio signal switching, with a 2-input 1-output single video switch, video signal/chroma signal 75Ω driver, and Y/C mixing circuit in one small package (SOT-26).

Features

- (1) Low power consumption achieved.
- (2) Low power supply voltage realized.
- (3) Frequency bandwidth without 75Ω driver: 10MHz with 75Ω driver: 7MHz
- (4) Cross talk 70dB When 4.43MHz
- (5) With SAG measures pin (75Ω driver and Y/C mix driver)

Package

- SOT-26A (with 75Ω driver)
- SOT-26B (without 75Ω driver)

Applications

- (1) TV
- (2) VTR
- (3) Video camera
- (4) Digital still camera
- (5) Other visual equipment

Line-up

Functions	Model Name	Input	Output	Clamp	6dB amp	75Ω driver	SAG measures pin	Power supply voltage
Switch	MM1501	2	1	×	×	×	×	4.5~13.0V
	MM1502			×	○	×	×	4.5~13.0V
	MM1503			○	×	×	×	4.5~13.0V
	MM1504			○	○	×	×	4.5~13.0V
	MM1505			×	×	○	×	4.5~13.0V
	MM1506			×	○	○	×	4.5~13.0V
	MM1507			○	×	○	×	4.5~13.0V
	MM1508			○	○	○	×	4.5~13.0V
Driver	MM1509	1	1	×	○	○	○	4.5~13.0V
	MM1510			○	○	○	○	4.5~13.0V
Y/C mix	MM1511	1	1	○/×	×	×	×	4.5~13.0V
	MM1512			○/×	○	○	○	4.5~13.0V

MM1507

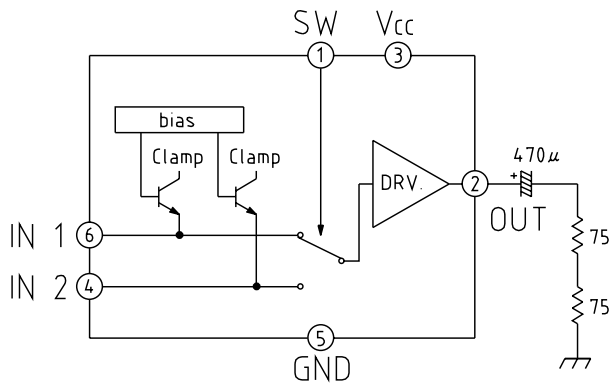

MM1508

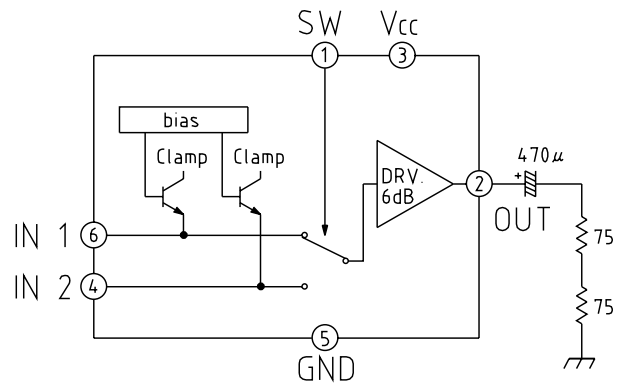

MM1509

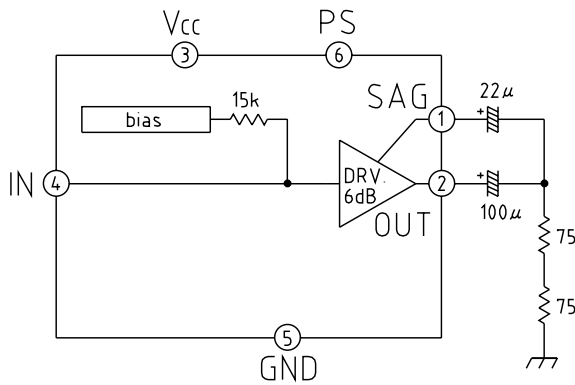

MM1510

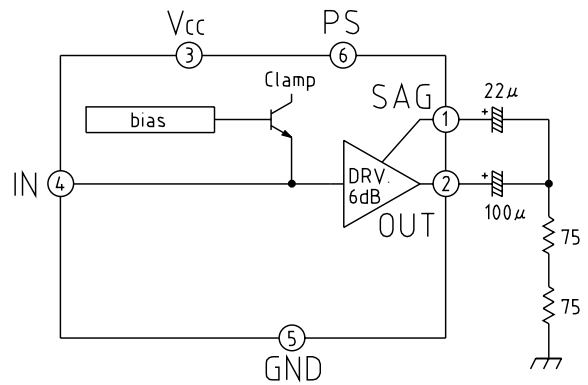

MM1511

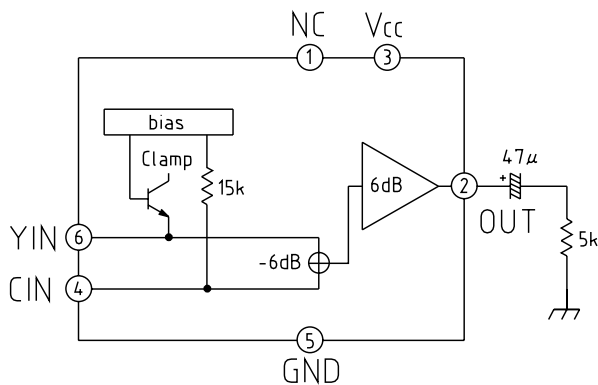

MM1512

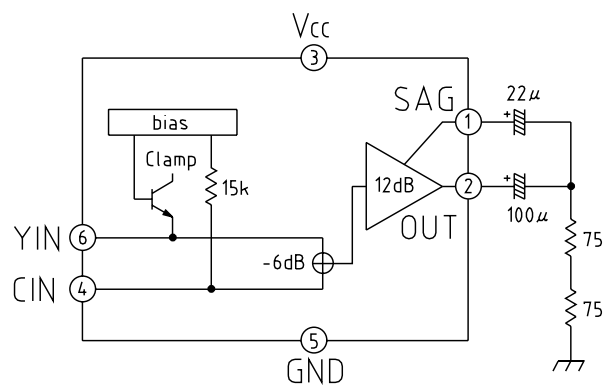

 MM1509

Item	Symbol	Measurement conditions	Min.	Typ.	Max.	Unit
Consumption current	I _{CC1}	Refer to measurement procedures		6.3	8.2	mA
Current consumption for PS	I _{CC2}	Refer to measurement procedures		20	30	μA
PS input voltage L	V _{PSL}	Refer to measurement procedures			0.3	V
PS input voltage H	V _{PSH}	Refer to measurement procedures	1.8			V
Input pin voltage	V _{IN}	No-signal, no-load	1.75	1.95	2.15	V
Output pin voltage	V _{OUT}	No-signal, no-load		2.35		V
Voltage gain	G _V	Refer to measurement procedures	5.5	6.0	6.5	dB
Frequency characteristic	f _c	Refer to measurement procedures	-1	0	+1	dB
Differential gain	V _{CC=9V} DG	Refer to measurement procedures	-3	0	+3	%
Differential phase	V _{CC=9V} DP	Refer to measurement procedures	-3	0	+3	deg
Output dynamic range	V _D	Refer to measurement procedures	2.9	3.2		V
Input impedance	Z _i			15		kΩ

 MM1510

Item	Symbol	Measurement conditions	Min.	Typ.	Max.	Unit
Consumption current	I _{CC1}	Refer to measurement procedures		6.4	8.3	mA
Current consumption for PS	I _{CC2}	Refer to measurement procedures		20	30	μA
PS input voltage L	V _{PSL}	Refer to measurement procedures			0.3	V
PS input voltage H	V _{PSH}	Refer to measurement procedures	1.8			V
Input pin voltage	V _{IN}	No-signal, no-load	1.15	1.35	1.55	V
Output pin voltage	V _{OUT}	No-signal, no-load		1.15		V
Voltage gain	G _V	Refer to measurement procedures	5.5	6.0	6.5	dB
Frequency characteristic	f _c	Refer to measurement procedures	-1	0	+1	dB
Differential gain	DG	Refer to measurement procedures	-3	0	+3	%
Differential phase	DP	Refer to measurement procedures	-3	0	+3	deg
Output dynamic range	V _D	Refer to measurement procedures	2.6	3.0		V

 MM1511

Item	Symbol	Measurement conditions	Min.	Typ.	Max.	Unit
Consumption current	I _{CC}	Refer to measurement procedures		4.4	5.7	mA
Y input pin voltage	V _{YIN}	No-signal, no-load	2.00	2.20	2.40	V
C input pin voltage	V _{CIN}	No-signal, no-load	1.85	2.05	2.25	V
Output pin voltage	V _{OUT}	No-signal, no-load		1.15		V
Voltage gain	G _V	Refer to measurement procedures	-0.5	0	6.5	dB
Frequency characteristic	f _c	Refer to measurement procedures	-1	0	+0.5	dB
Differential gain	DG	Refer to measurement procedures	-3	0	+3	%
Differential phase	DP	Refer to measurement procedures	-3	0	+3	deg
Y output dynamic range	V _{DY}	Refer to measurement procedures	2.6	2.9		V
C output dynamic range	V _{DC}	Refer to measurement procedures	2.0			V
C input impedance	Z _i			15		kΩ
Output impedance	Z _o			25		Ω



HY57V161610ETP-I

2 Banks x 512K x 16 Bit Synchronous DRAM

DESCRIPTION

THE Hynix HY57V161610E is a 16,777,216-bits CMOS Synchronous DRAM, ideally suited for the main memory and graphic applications which require large memory density and high bandwidth. HY57V161610E is organized as 2banks of 524,288x16.

HY57V161610E is offering fully synchronous operation referenced to a positive edge clock. All inputs and outputs are synchronized with the rising edge of the clock input. The data paths are internally pipelined to achieve very high bandwidth. All input and output voltage levels are compatible with LVTTTL.

Programmable options include the length of pipeline (Read latency of 1,2 or 3), the number of consecutive read or write cycles initiated by a single control command (Burst length of 1,2,4,8 or full page), and the burst count sequence(sequential or interleave). A burst of read or write cycles in progress can be terminated by a burst terminate command or can be interrupted and replaced by a new burst read or write command on any cycle. (This pipeline design is not restricted by a `2N` rule.)

FEATURES

- Single 3.0V to 3.6V power supply
- All device pins are compatible with LVTTTL interface
- JEDEC standard 400mil 50pin TSOP-II with 0.8mm of pin pitch
- All inputs and outputs referenced to positive edge of system clock
- Data mask function by UDQM/LDQM
- Internal two banks operation
- Auto refresh and self refresh
- 4096 refresh cycles / 64ms
- Programmable Burst Length and Burst Type
 - 1, 2, 4, 8 and Full Page for Sequence Burst
 - 1, 2, 4 and 8 for Interleave Burst
- Programmable $\overline{\text{CAS}}$ Latency ; 1, 2, 3 Clocks
- Pb-free Package

ORDERING INFORMATION

Part No.	Clock Frequency	Organization	Interface	Package
HY57V161610ETP-5I	200MHz	2Banks x 512Kbits x 16	LVTTTL	400mil 50pin TSOP II (Pb free)
HY57V161610ETP-55I	183MHz			
HY57V161610ETP-6I	166MHz			
HY57V161610ETP-7I	143MHz			
HY57V161610ETP-8I	125MHz			
HY57V161610ETP-10I	100MHz			
HY57V161610ETP-15I	66MHz			

Note :

1. VDD(min) of HY57V161610ETP-5I/55I is 3.15V
2. Hynix supports lead free part for each speed grade with same specification.

This document is a general product description and is subject to change without notice. Hynix Semiconductor does not assume any responsibility for use of circuits described. No patent licenses are implied

Rev. 0.1 / Nov. 2003

1



HY57V161610ETP-I

PIN CONFIGURATION

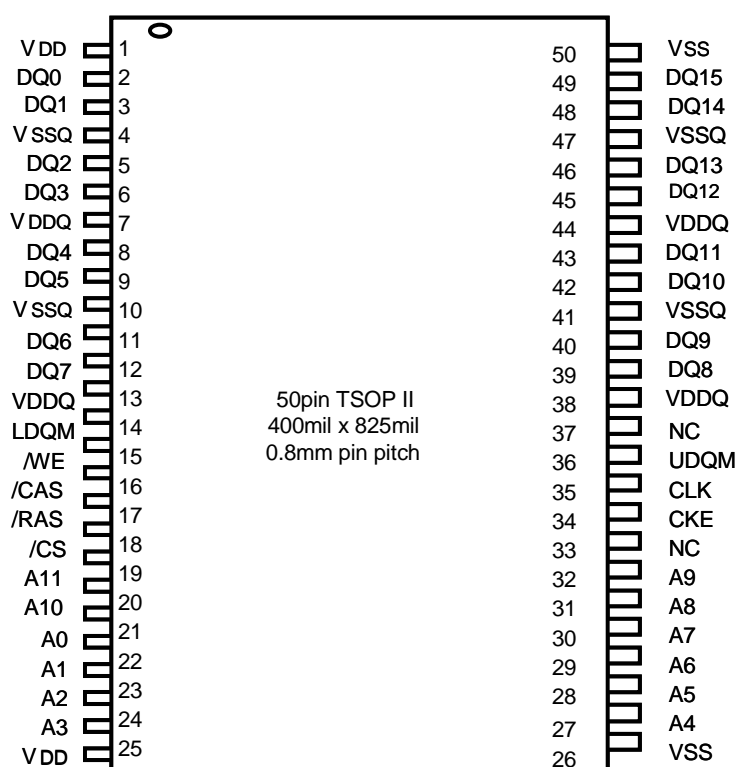

PIN DESCRIPTION

PIN	PIN NAME	DESCRIPTION
CLK	Clock	The system clock input. All other inputs are referenced to the SDRAM on the rising edge of CLK.
CKE	Clock Enable	Controls internal clock signal and when deactivated, the SDRAM will be one of the states among power down, suspend or self refresh.
\overline{CS}	Chip Select	Command input enable or mask except CLK, CKE and DQM
BA	Bank Address	Select either one of banks during both \overline{RAS} and \overline{CAS} activity.
A0 ~ A10	Address	Row Address : RA0 ~ RA10, Column Address : CA0 ~ CA7 Auto-precharge flag : A10
\overline{RAS} , \overline{CAS} , \overline{WE}	Row Address Strobe, Column Address Strobe, Write Enable	\overline{RAS} , \overline{CAS} and \overline{WE} define the operation. Refer function truth table for details
LDQM, UDQM	Data Input/Output Mask	DQM control output buffer in read mode and mask input data in write mode
DQ0 ~ DQ15	Data Input/Output	Multiplexed data input / output pin
VDD/VSS	Power Supply/Ground	Power supply for internal circuit and input buffer
VDDQ/VSSQ	Data Output Power/Ground	Power supply for DQ
NC	No Connection	No connection



HY57V161610ETP-I

FUNCTIONAL BLOCK DIAGRAM

1Mx16 Synchronous DRAM

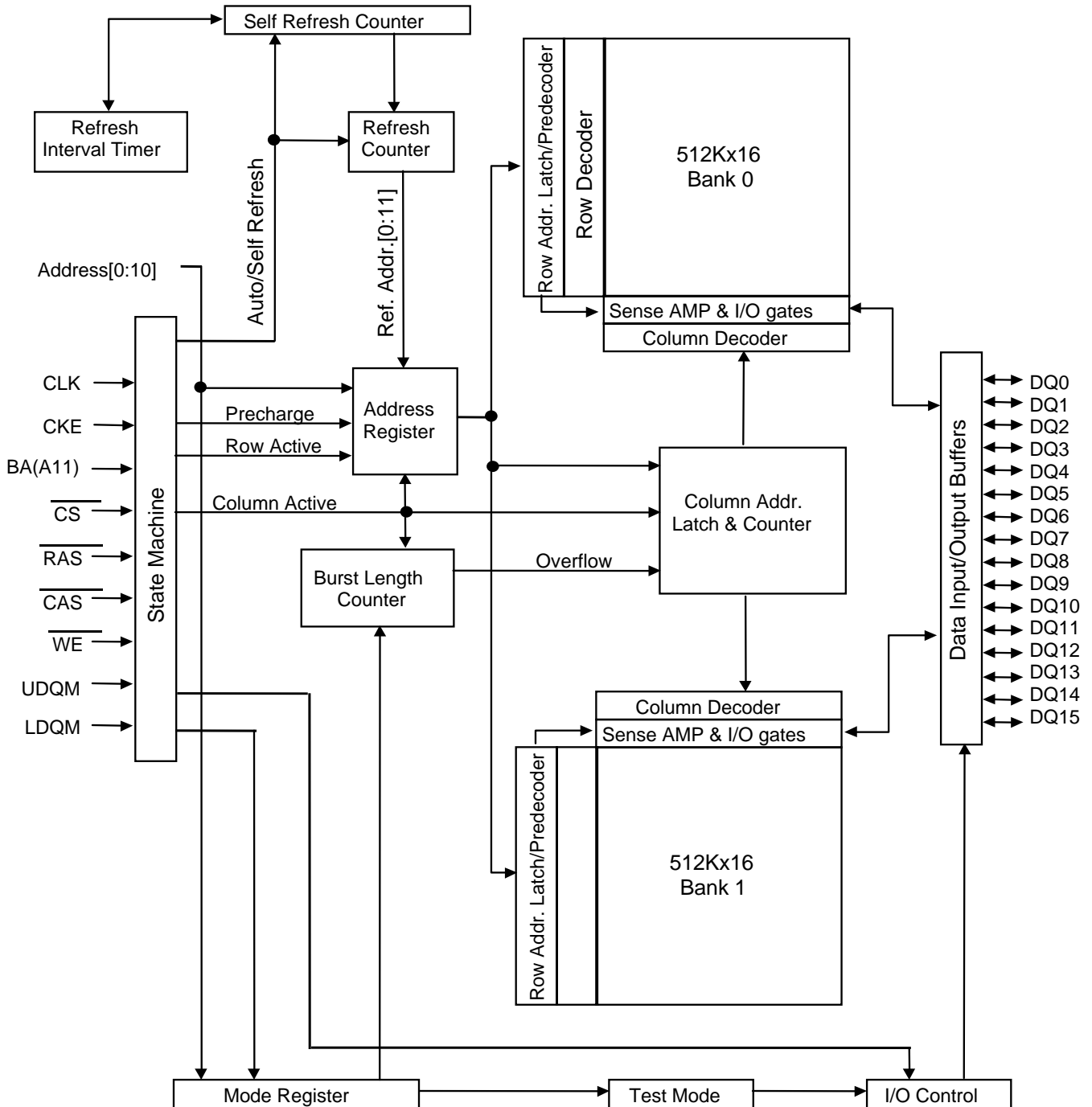



HY57V161610ETP-I

COMMAND TRUTH TABLE

Command	CKEn-1	CKEn	\overline{CS}	\overline{RAS}	\overline{CAS}	\overline{WE}	DQM	A0~A9	A10/ AP	BA	Note	
Mode Register Set	H	X	L	L	L	L	X	OP code				
No Operation	H	X	H	X	X	X	X	X				
			L	H	H	H						
Bank Active	H	X	L	L	H	H	X	Row Address		V		
Read	H	X	L	H	L	H	X	Column Address	L	V		
Read with Auto precharge									H			
Write	H	X	L	H	L	L	X	Column Address	L	V		
Write with Auto precharge									H			
Precharge All Bank	H	X	L	L	H	L	X	X	H	X		
Precharge selected Bank									L	V		
Burst Stop	H	X	L	H	H	L	X	X				
U/LDQM	H	X					V	X				
Auto Refresh	H	H	L	L	L	H	X	X				
Burst-READ-Single-WRITE	H	X	L	L	L	L	X	A9 Pin High (Other Pins OP code)				
Self Refresh ¹	Entry	H	L	L	L	L	H	X	X			
	Exit	L	H	H	X	X	X	X				
Precharge power down	Entry	H	L	H	X	X	X	X	X			
				L	H	H	H					
	Exit	L	H	H	X	X	X	X				
				L	H	H	H					
Clock Suspend	Entry	H	L	H	X	X	X	X	X			
				L	V	V	V					
	Exit	L	H	X				X				

Note :

1. Exiting Self Refresh occurs by asynchronously bringing CKE from low to high.
2. X=Do not care, L=Low, H=High, BA=Bank Address, RA= Row Address, CA=Column Address, Opcode=Operand Code, NOP=No Operation.



March 1995
Revised February 2005

74LCX32

Low Voltage Quad 2-Input OR Gate with 5V Tolerant Inputs

General Description

The LCX32 contains four 2-input OR gates. The inputs tolerate voltages up to 7V allowing the interface of 5V systems to 3V systems.

The 74LCX32 is fabricated with advanced CMOS technology to achieve high speed operation while maintaining CMOS low power dissipation.

Features

- 5V tolerant inputs
- 2.3V–3.6V V_{CC} specifications provided
- 5.5 ns t_{PD} max ($V_{CC} = 3.3V$), 10 μA I_{CC} max
- Power down high impedance inputs and outputs
- ± 24 mA output drive ($V_{CC} = 3.0V$)
- Implements patented noise/EMI reduction circuitry
- Latch-up performance exceeds JEDEC 78 conditions
- ESD performance:
 - Human body model > 2000V
 - Machine model > 150V
- Leadless Pb-Free DQFN package

Ordering Code:

Order Number	Package Number	Package Description
74LCX32M	M14A	14-Lead Small Outline Integrated Circuit (SOIC), JEDEC MS-012, 0.150" Narrow
74LCX32MX_NL (Note 2)	M14A	Pb-Free 14-Lead Small Outline Integrated Circuit (SOIC), JEDEC MS-012, 0.150" Narrow
74LCX32SJ	M14D	Pb-Free 14-Lead Small Outline Package (SOP), EIAJ TYPE II, 5.3mm Wide
74LCX32BQX (Note 1)	MLP014A	Pb-Free 14-Terminal Depopulated Quad Very-Thin Flat Pack No Leads (DQFN), JEDEC MO-241, 2.5 x 3.0mm
74LCX32MTC	MTC14	14-Lead Thin Shrink Small Outline Package (TSSOP), JEDEC MO-153, 4.4mm Wide
74LCX32MTCX_NL (Note 2)	MTC14	Pb-Free 14-Lead Thin Shrink Small Outline Package (TSSOP), JEDEC MO-153, 4.4mm Wide

Devices also available in Tape and Reel. Specify by appending the suffix letter "X" to the ordering code.

Pb-Free package per JEDEC J-STD-020B.

Note 1: DQFN package available in Tape and Reel only.

Note 2: "_NL" indicates Pb-Free package (per JEDEC J-STD-020B). Device available in Tape and Reel only.

Logic Symbol

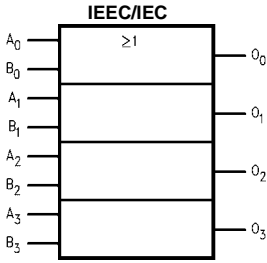

Pin Descriptions

Pin Names	Description
A _n , B _n	Inputs
O _n	Outputs

Connection Diagrams

Pin Assignments for SOIC, SOP, and TSSOP

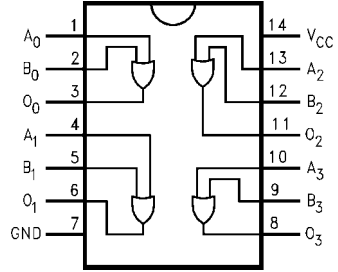

Pad Assignment for DQFN

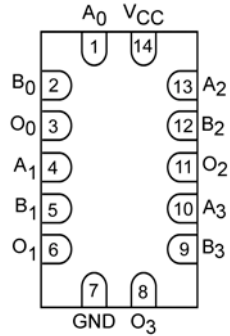

(Top View)



GENERAL DESCRIPTION

The AK4589 is a single chip CODEC that includes two channels of ADC and eight channels of DAC. The ADC outputs 24bit data and the DAC accepts up to 24bit input data. The ADC has the Enhanced Dual Bit architecture with wide dynamic range. The DAC introduces the new developed Advanced Multi-Bit architecture, and achieves wider dynamic range and lower outband noise. The AK4589 has a dynamic range of 102dB for ADC, 114dB for DAC and is well suited for digital surround for home theater audio. The AK4589 also has the balance volume control corresponding to the Dolby Digital (AC-3) system.

The also has digital audio receiver (DIR) and transmitter (DIT) compatible with 192kHz, 24bits. The DIR has 8-channel input selector and can automatically detect a Non-PCM bit stream. The AK4589 provides a compatibility of hardware and software with the AK4588.

*Dolby Digital (AC-3) is a trademark of Dolby Laboratories.

FEATURES

□ ADC/DAC part

- **2ch 24bit ADC**
 - 64x Oversampling
 - Sampling Rate up to 96kHz
 - Linear Phase Digital Anti-Alias Filter
 - Single-Ended Input
 - S/(N+D): 92dB
 - Dynamic Range, S/N: 102dB
 - Digital HPF for offset cancellation
 - Overflow flag
- **8ch 24bit DAC**
 - 128x Oversampling
 - Sampling Rate up to 192kHz
 - 24bit 8 times Digital Filter
 - Differential Outputs
 - On-chip Switched-Capacitor Filter
 - S/(N+D): 94dB
 - Dynamic Range, S/N: 114dB
 - Individual channel digital volume with 128 levels and 0.5dB step
 - Soft mute
 - De-emphasis for 32kHz, 44.1kHz, 48kHz
 - Zero Detect Function
- **High Jitter Tolerance**
- **External Master Clock Input:**
 - 256fs, 384fs, 512fs (fs=32kHz ~ 48kHz)
 - 128fs, 192fs, 256fs (fs=64kHz ~ 96kHz)
 - 128fs (fs=120kHz ~ 192kHz)

- DIR/DIT Part**
 - AES3, IEC60958, S/PDIF, EIAJ CP1201 Compatible
 - Low jitter Analog PLL
 - PLL Lock Range : 32kHz to 192kHz
 - Clock Source: PLL or X'tal
 - 8-channel Receiver input
 - 2-channel Transmission output (Through output or DIT)
 - Auxiliary digital input
 - De-emphasis for 32kHz, 44.1kHz, 48kHz and 96kHz
 - Detection Functions
 - Non-PCM Bit Stream Detection
 - DTS-CD Bit Stream Detection
 - Sampling Frequency Detection
(32kHz, 44.1kHz, 48kHz, 88.2kHz, 96kHz, 176.4kHz, 192kHz)
 - Unlock & Parity Error Detection
 - Validity Flag Detection
 - Up to 24bit Audio Data Format
 - Audio I/F: Master or Slave Mode
 - 40-bit Channel Status Buffer
 - Burst Preamble bit Pc and Pd Buffer for Non-PCM bit stream
 - Q-subcode Buffer for CD bit stream
 - Serial μ P I/F
 - Two Master Clock Outputs: 64fs/128fs/256fs/512fs
- TTL Level Digital I/F**
- 4-wire Serial and I²C Bus μ P I/F for mode setting**
- Operating Voltage: 4.75 to 5.25V with 5V tolerance**
- Power Supply for output buffer: 2.7 to 5.25V**
- 80pin LQFP Package (0.5mm pitch)**
- AK4588 compatible w/o analog outputs**

■ Block Diagram

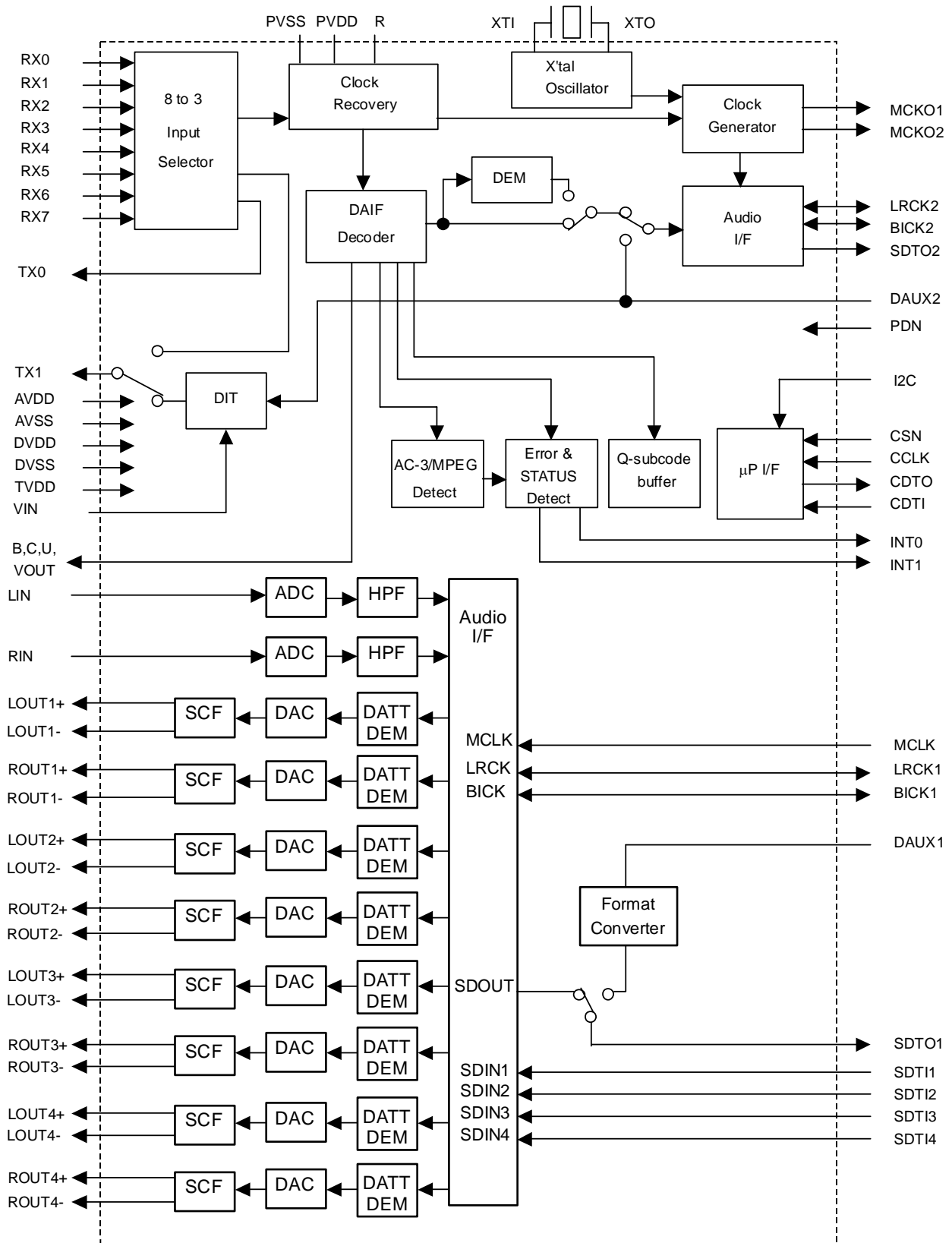

ASAHI KASEI

[AK4589]

■ Ordering Guide

AK4589VQ -10 ~ +70°C 80pin LQFP(0.5mm pitch)
 AKD4589 Evaluation Board for AK4589

■ Pin Layout

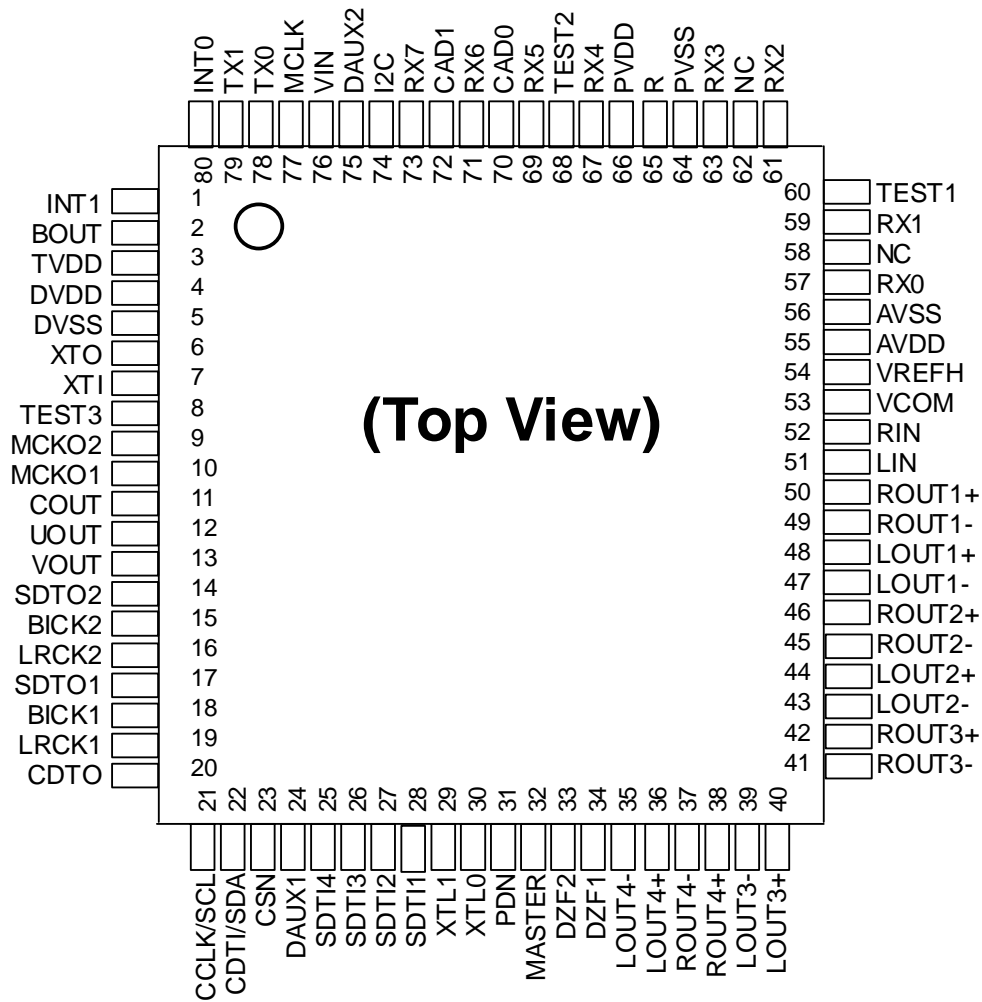

PIN/FUNCTION			
No.	Pin Name	I/O	Function
1	INT1	O	Interrupt 1 Pin
2	BOUT	O	Block-Start Output Pin for Receiver Input "H" during first 40 flames.
3	TVDD	-	Output Buffer Power Supply Pin, 2.7V~5.25V
4	DVDD	-	Digital Power Supply Pin, 4.75V~5.25V
5	DVSS	-	Digital Ground Pin
6	XTO	O	X'tal Output Pin
7	XTI	I	X'tal Input Pin
8	TEST3	I	Test 3 Pin This pin should be connected to DVSS.
9	MCKO2	O	Master Clock Output 2 Pin
10	MCKO1	O	Master Clock Output 1 Pin
11	COOUT	O	C-bit Output Pin for Receiver Input
12	UOUT	O	U-bit Output Pin for Receiver Input
13	VOOUT	O	V-bit Output Pin for Receiver Input
14	SDTO2	O	Audio Serial Data Output Pin (DIR/DIT part)
15	BICK2	I/O	Audio Serial Data Clock Pin (DIR/DIT part)
16	LRCK2	I/O	Channel Clock Pin (DIR/DIT part)
17	SDTO1	O	Audio Serial Data Output Pin (ADC/DAC part)
18	BICK1	I/O	Audio Serial Data Clock Pin (ADC/DAC part)
19	LRCK1	I/O	Input Channel Clock Pin
20	CDTO	O	Control Data Output Pin in Serial Mode, I2C= "L".
21	CCLK	I	Control Data Clock Pin in Serial Mode, I2C= "L"
	SCL	I	Control Data Clock Pin in Serial Mode, I2C= "H"
22	CDTI	I	Control Data Input Pin in Serial Mode, I2C= "L".
	SDA	I/O	Control Data Pin in Serial Mode, I2C= "H".
23	CSN	I	Chip Select Pin in Serial Mode, I2C= "L".
		I	This pin should be connected to DVSS, I2C= "H".
24	DAUX1	I	AUX Audio Serial Data Input Pin (ADC/DAC part)
25	SDTI4	I	DAC4 Audio Serial Data Input Pin
26	SDTI3	I	DAC3 Audio Serial Data Input Pin
27	SDTI2	I	DAC2 Audio Serial Data Input Pin
28	SDTI1	I	DAC1 Audio Serial Data Input Pin
29	XTL1	I	X'tal Frequency Select 0 Pin
30	XTL0	I	X'tal Frequency Select 1 Pin

No.	Pin Name	I/O	Function	
31	PDN	I	Power-Down Mode Pin When "L", the AK4589 is powered-down, all digital output pins go "L", all registers are reset. When CAD1/0 pins are changed, the AK4589 should be reset by PDN pin.	
32	MASTER	I	Master Mode Select Pin "H": Master mode, "L": Slave mode	
33	DZF2	O	Zero Input Detect 2 Pin (Table 13) When the input data of the group 1 follow total 8192 LRCK cycles with "0" input data, this pin goes to "H". And when RSTN bit is "0", PWDAN bit is "0", this pin goes to "H". It always is in "L" when P/S pin is "H".	
	OVF	O	Analog Input Overflow Detect Pin This pin goes to "H" if the analog input of Lch or Rch overflows.	
34	DZF1	O	Zero Input Detect 1 Pin (Table 13) When the input data of the group 1 follow total 8192 LRCK cycles with "0" input data, this pin goes to "H". And when RSTN bit is "0", PWDAN bit is "0", this pin goes to "H". Output is selected by setting DZFE pin when P/S pin is "H".	
35	LOUT4-	O	DAC4 Lch Negative Analog Output Pin	470pF capacitor should be connected between LOUT4- and LOUT4+.
36	LOUT4+	O	DAC4 Lch Positive Analog Output Pin	
37	ROUT4-	O	DAC4 Rch Negative Analog Output Pin	470pF capacitor should be connected between ROUT4- and ROUT4+.
38	ROUT4+	O	DAC4 Rch Positive Analog Output Pin	
39	LOUT3-	O	DAC3 Lch Negative Analog Output Pin	470pF capacitor should be connected between LOUT3- and LOUT3+.
40	LOUT3+	O	DAC3 Lch Positive Analog Output Pin	
41	ROUT3-	O	DAC3 Rch Negative Analog Output Pin	470pF capacitor should be connected between ROUT3- and ROUT3+.
42	ROUT3+	O	DAC3 Rch Positive Analog Output Pin	
43	LOUT2-	O	DAC2 Lch Negative Analog Output Pin	470pF capacitor should be connected between LOUT2- and LOUT2+.
44	LOUT2+	O	DAC2 Lch Positive Analog Output Pin	
45	ROUT2-	O	DAC2 Rch Negative Analog Output Pin	470pF capacitor should be connected between ROUT2- and ROUT2+.
46	ROUT2+	O	DAC2 Rch Positive Analog Output Pin	
47	LOUT1-	O	DAC1 Lch Negative Analog Output Pin	470pF capacitor should be connected between LOUT1- and LOUT1+.
48	LOUT1+	O	DAC1 Lch Positive Analog Output Pin	
49	ROUT1-	O	DAC1 Rch Negative Analog Output Pin	470pF capacitor should be connected between ROUT1- and ROUT1+.
50	ROUT1+	O	DAC1 Rch Positive Analog Output Pin	
51	LIN	I	Lch Analog Input Pin	
52	RIN	I	Rch Analog Input Pin	
53	VCOM	-	Common Voltage Output Pin 2.2μF capacitor should be connected to AVSS externally.	
54	VREFH	-	Positive Voltage Reference Input Pin, AVDD	

No.	Pin Name	I/O	Function
55	AVDD	-	Analog Power Supply Pin, 4.75V~5.25V
56	AVSS	-	Analog Ground Pin, 0V
57	RX0	I	Receiver Channel 0 Pin (Internal biased pin. Internally biased at PVDD/2)
58	NC	-	No Connect pin No internal bonding. This pin should be connected to PVSS.
59	RX1	I	Receiver Channel 1 Pin (Internal biased pin. Internally biased at PVDD/2)
60	TEST1	I	Test 1 Pin This pin should be connected to PVSS.
61	RX2	I	Receiver Channel 2 Pin (Internal biased pin. Internally biased at PVDD/2)
62	NC	-	No Connect pin No internal bonding. This pin should be connected to PVSS.
63	RX3	I	Receiver Channel 3 Pin (Internal biased pin. Internally biased at PVDD/2)
64	PVSS	-	PLL Ground pin
65	R	-	External Resistor Pin 12k Ω +/-1% resistor should be connected to PVSS externally.
66	PVDD	-	PLL Power supply Pin, 4.75V~5.25V
67	RX4	I	Receiver Channel 4 Pin (Internal biased pin. Internally biased at PVDD/2)
68	TEST2	I	Test 2 Pin This pin should be connected to PVSS.
69	RX5	I	Receiver Channel 5 Pin (Internal biased pin. Internally biased at PVDD/2)
70	CAD0	I	Chip Address 0 Pin (ADC/DAC part)
71	RX6	I	Receiver Channel 6 Pin (Internal biased pin. Internally biased at PVDD/2)
72	CAD1	I	Chip Address 1 Pin (ADC/DAC part)
73	RX7	I	Receiver Channel 7 Pin (Internal biased pin. Internally biased at PVDD/2)
74	I2C	I	Control Mode Select Pin. “L”: 4-wire Serial, “H”: I ² C Bus
75	DAUX2	I	Auxiliary Audio Data Input Pin (DIR/DIT part)
76	VIN	I	V-bit Input Pin for Transmitter Output
77	MCLK	I	Master Clock Input Pin
78	TX0	O	Transmit Channel (Through Data) Output 0 Pin
79	TX1	O	Transmit Channel Output1 pin When DIT bit = “0”, Through Data. When DIT bit = “1”, DAUX2 Data.
80	INT0	O	Interrupt 0 Pin

Note: All input pins except internal biased pins and Analog input pins (RX0-7, LIN, RIN) should not be left floating.

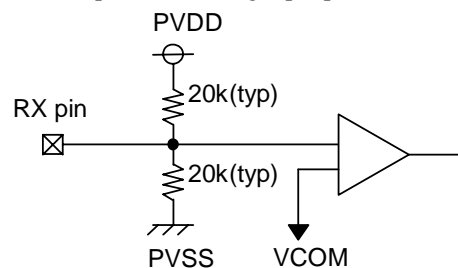

Internal biased pin Circuit

■ Handling of Unused Pin

The unused I/O pins should be processed appropriately as below.

Classification	Pin Name	Setting
Analog	RX0-7, LOUT1-4, ROUT1-4, LIN, RIN	These pins should be open.
Digital	INT0-1, BOUT, XTO, MCKO1-2, COUT, UOUT, VOUT, SDTO1-2, CDTO, DZF1-2, TX1-0	These pins should be open.
	CSN, DAUX1-2, SDTI1-4, XTL0-1	These pins should be connected to DVSS.
	TEST1-3	These pins should be connected to PVSS.



CS49400 Family DSP

Multi-Standard Audio Decoder

Features

- CS49300 Legacy Audio Decoder Support
- Dolby Digital EX™, Dolby Pro Logic II™
- DTS-ES 96/24™, DTS 96/24™, DTS-ES Discrete 6.1™, DTS-ES Matrix 6.1™, DTS Digital Surround™ and DTS Virtual 5.1™
- MPEG-2: AAC Multichannel 5.1
- MPEG Multichannel and Musicam
- MPEG-1/2, Layer III (MP3)
- DTS Neo:6™, LOGIC7®, SRS Circle Surround II™
- Cirrus Extra Surround™, Cirrus Original Surround 6.1 (C.O.S. 6.1)™
- THX Surround EX™, THX Ultra2 Cinema™
- 12-Channel Serial Audio Inputs
- Integrated 8K Byte Input Buffer
- Powerful 32-bit Audio DSP
- Customer Software Security Keys
- Large On-chip X, Y, and Program RAM
- Supports SDRAM, SRAM, FLASH memories
- 16-channel PCM output
- Dual S/PDIF Transmitters
- SPI Serial, and Motorola® and Intel® Parallel Host Control Interfaces
- GPIO support for all common sub-circuits

Description

The CS49400 Audio Decoder DSP is targeted as a market-specific consumer entertainment processor for AV Receivers and DVD Audio/Video Players. The device is constructed using an enhanced version of the CS49300 Family DSP audio decoder followed by a 32-bit programmable post-processor DSP, which gives the designer the ability to add product differentiation through the Cirrus Framework™ programming structure and Framework module library. Dolby Digital Pro Logic II, DTS Digital Surround, MPEG Multichannel, and Cirrus Original Surround 6.1 PCM Effects Processor (capable of generating such DSP audio modes as: Hall, Theater, Church) are included in the cost of the CS49400 Family DSP. Additional algorithms available through the Crystal Ware™ Software Licensing Program, give the designer the ability to further deliver end-product differentiation.

The CS49400 contains sufficient on-chip SRAM to support decoding all major audio decoding algorithms available today including: AAC Multichannel, DTS 96/24, DTS-ES 96/24. The CS49400 also supports a glueless SDRAM/SRAM for increased all-channel delays. The SRAM interface also supports connection to an external byte-wide EPROM for code storage or Flash memory thus allowing products to be field-upgradable as new audio algorithms are developed.

This chip, teamed with Crystal Ware™ certified decoder library, Cirrus digital interface products and mixed signal data converters, enables the conception and design of next generation digital entertainment products.

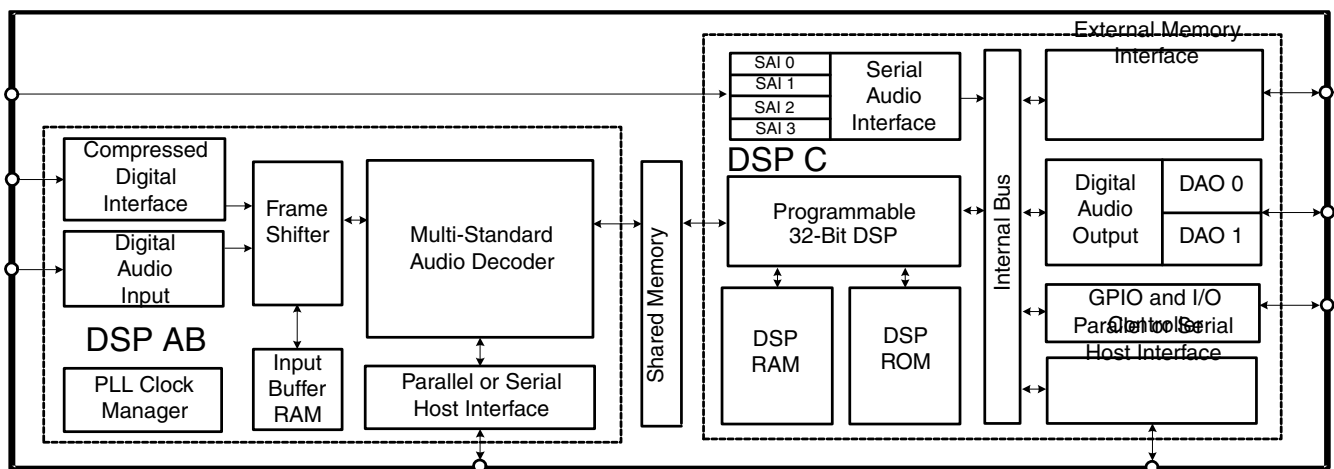

This document contains information for a new product.
Cirrus Logic reserves the right to modify this product without notice.



2. OVERVIEW

The CS49400 is a 24-bit fixed-point decoder DSP followed by a 32-bit fixed point programmable post-processor DSP. The decoder portion of the CS49400 is referred to as “DSPAB”. The post-processor DSP is referred to as “DSPC”. Both DSPAB and DSPC include their own dedicated peripherals such as serial and parallel control ports, and serial audio interfaces. DSPC also has an external memory interface which supports SRAM/SDRAM/EPROM.

All the decoding/processing algorithms listed below require delivery of PCM or IEC61937-packed compressed data via I2S or LJ formatted digital audio to the CS49400. Today the CS49400 will support all of the following decoding/processing standards:

- PCM Pass-Through/PCM Upsampler
- Dolby Digital™ (with Dolby Pro Logic™)
- Dolby Digital Pro Logic II™
- Dolby Digital EX™
- Dolby Digital EX Pro Logic II™
- MPEG-2, Advanced Audio Coding Algorithm (AAC)
- MPEG Multichannel
- MPEG Multichannel with Dolby Pro Logic II™
- MPEG-1/2, Layer III (MP3)
- DTS Digital Surround™
- DTS 96/24™ (Front-end Decoder)
- DTS Digital Surround™ with Dolby Pro Logic II™
- DTS-ES Extended Surround™ (DTS-ES Discrete 6.1 and DTS-ES Matrix 6.1)
- DTS-ES 96/24™ (Front-end Decoder)
- DTS Neo:6™
- LOGIC7®
- SRS Circle Surround™ II

- HDCD®

All of the above audio decoding/processing algorithms and the associated application notes (AN208 and their corresponding appendices) are available through the Crystal Ware™ Software Licensing Program. Please refer to AN208 for the latest listing of application codes for DSPAB.

DSPC is unique to DSPAB in the sense that the designer may choose to just load a standard or enhanced application code (.ULD file) from the Crystal Ware Software Library or if they have access to the Cirrus Framework DSPC Development Kit, they may choose to build their own application code from a variety of modules. A DSPC application code contains all of the necessary post-processing modules, such as Crossbar Mixer, Pro Logic Module, Bass Manager Module, and Audio Manager (Kernel). A module is just a single processing module, such as Tone Control, Parametric/Graphic EQ, or Dolby Pro Logic matrix decoder. DSPC on the CS49400 will support the following post-processing application codes and/or modules:

- Standard Post-Processor (includes the following modules all compiled into one .ULD file): Downmixer module, Dualzone module, Crossbar Mixer module, 7.1 Channel Bass Manager module, Audio Manager module (Volume Control, Trim Control and Channel Remap), and Delay module
- Advanced Post-Processor (includes the all of the standard post-processing modules plus the Tone Control module, Parametric EQ module, Re-EQ module in all compiled into one .ULD)
- Dolby Pro Logic™
- Dolby Pro Logic II™
- SRS Circle Surround II™
- DTS Neo:6™
- LOGIC7®
- THX® Surround EX™ 7.1 Channel Post-Processor



- THX[®] Ultra2 Cinema[™] 7.1 Channel Post-Processor
- Cirrus Extra Surround[™]
- Cirrus Original Multichannel Surround[™]
- Virtual Dolby Digital[™]/Virtual Dolby Digital Pro Logic II[™] Virtualizer Module
- VMaX VirtualTheater[™] Virtualizer Module
- HDCD[®] Multichannel Decoder
- DVD-Audio/Video and Multichannel SACD Bass Management
- DTS/DTS-ES 96/24[™] Back-End Decoder
- DTS/DTS-ES 96/24[™] Back-End Decoder with THX[®] Ultra2 Cinema[™]

All of the above audio post-processing applications codes and/or Cirrus Framework[™] modules and the associated application notes (AN209 and the associated appendices) are available through the Crystal Ware[™] Software Licensing Program. All standard or enhanced post-processing code modules are only available to customers who qualify for the Cirrus Framework[™] CS49400 Family DSPC Programming Kit. Please refer to AN209 for the latest listing of application codes and Cirrus Framework[™] modules available for DSPC.

2.1 DSPAB

DSPAB is an enhanced version of the CS49300. It was designed to have legacy code support for all decoder applications developed for the CS49300. It includes performance enhancements such as the ability to decode AAC without the need for external SRAM memory. DSPAB has a Digital Audio Input (DAI) and a Compressed Data Input (CDI) port for data delivery in either I²S or LJ format. DSPAB can be controlled serially using the SPI standard and can also be controlled via a Parallel host control port using the Motorola[®] or Intel[®] communication standards.

2.2 DSPC

DSPC is a 32-bit, general-purpose, fixed-point RAM-based processor which includes on-chip ROM tables. It has been designed with a generous amount of on-chip program and data RAM, and has all necessary peripherals required to support the latest standards in consumer entertainment products such as AV receivers and DVD-Audio/Video players.

DSPC has on-chip data and program RAM, and both external SDRAM and SRAM memory interfaces. These interfaces can be used to expand the data memory. DSPC also has its own 8-channel digital audio input for post-processing PCM from a Multichannel Super Audio CD (SACD) input or DVD-Audio/Video input, via high-performance A/Ds or from some other type of multichannel digital input, capable of delivering 4 stereo digital audio channels such as IEEE1394 (a.k.a. I-Link[®] or Firewire[®]). Data can be delivered to this port using the standard audio formats (I²S or LJ). DSPC can be controlled serially using the SPI standard or via Parallel host control port using the Motorola[®] or Intel[®] standard. DSPC has a Digital Audio output port that has eight stereo serial data outputs for a total of 16 channels. Data can be delivered from these outputs in serial I²S or LJ format. Two of these outputs (AUDAT3, AUDAT7) can be configured as a IEC60958-format S/PDIF transmitter.

This document focuses on the electrical features of the CS49400. The features are described from a hardware design perspective. It should be understood that not all of the features portrayed in this document are supported by all of the versions of application code available. The application code user's guides should be consulted to determine which hardware features are supported by the software.

Please note that a download of application software is required each time the part is powered up. This term should be interpreted as meaning the transfer of application code into the internal memory of the part



from either an external microcontroller or through one of the boot procedures listed in Section 8.

3. TYPICAL CONNECTION DIAGRAMS

Four typical connection diagrams have been presented to illustrate using the part with the different communication modes available. They are as follows:

Figure 27, "SPI Control with External Memory - 144 Pin Package" on page 38.

Figure 28, "Intel® Parallel Control Mode - 144 Pin Package" on page 39.

Figure 29, "Motorola® Parallel Control Mode - 144 Pin Package" on page 40.

The following should be noted when viewing the typical connection diagrams:

Note: The pins are grouped functionally in each of the typical connection diagrams. Please be aware that the CS49400 symbol may appear differently in each diagram.

The external memory interface is supported when a serial or parallel communication mode has been chosen.

3.1 Multiplexed Pins

The CS49400 incorporates a large amount of flexibility into a 144 pin package. The pins are internally multiplexed to serve multiple purposes. Some pins are designed to operate in one mode at power up, and serve a different purpose when the DSP is running. Other pins have functionality which can be controlled by the application running on the DSP. In order to better explain the behavior of the part, the pins which are multiplexed have been given multiple names. Each name is specific to the pin's operation in a particular mode.

In this document, pins will be referred to by their functionality. Section 12 "Pin Description" on page 86 describes each pin of the CS49400 and lists all of its names. Please refer to this section when exact pin numbers are in question.

3.2 Termination Requirements

The CS49400 incorporates open drain pins which must be pulled high for proper operation. $\overline{\text{FINTREQ}}$ and $\overline{\text{INTREQ}}$ are always open drains which requires a pull-up for proper operation.

Due to the internal, multiplexed design of the pins, certain signals may or may not require termination depending on the mode being used. If a parallel host communication mode is not being used, all parallel control pins must be terminated or driven as these pins will come up as high impedance inputs and will be prone to oscillation if they are left floating. The specific termination requirements may vary since the state of some of the GPIO pins will determine the communication mode at the rising edge of reset (please see Section 6 "Control" on page 41 for more information). For the explicit termination requirements of each communication mode please see the typical connection diagrams.

Generally a 3.3k Ohm resistor is recommended for open drain and mode select pins. A 10k Ohm resistor is sufficient for all other unused inputs.

3.3 Phase Locked Loop Filter

The internal phase locked loop (PLL) of the CS49400 requires an external filter. The topology of this filter is shown in the typical connection diagrams. The component values are shown below. Care should be taken when laying out the filter circuitry to minimize trace lengths and to avoid any high frequency signals. Any noise coupled onto the filter circuit will be directly coupled into the PLL, which could affect performance.

Reference Designator	Value
C1	2.2uF
C2	1200pF
C3	68pF
R1	3k Ohm

Table 1. PLL Filter Component Values



4. POWER

The CS49400 requires a 2.5V digital power supply for the core logic and 2.5V I/O and a 2.5V analog power supply for the internal PLL. For systems with external memory that runs on 3.3V, a 3.3V digital power supply is required on the VDDSD pins along with four digital grounds on VSSSD. There are seven digital power pins, VDD1 through VDD7, along with seven digital grounds, VSS1 through VSS7. There is one analog power pin, PLLVDD, and one analog ground, PLLVSS. The recommendations given below for decoupling and power conditioning of the CS49400 will help to ensure reliable performance.

4.1 Decoupling

It is necessary to decouple the power supply by placing capacitors directly between the power and ground of the CS49400. Each pair of power/ground pins (VDD1/VSS1, etc.) should have its own decoupling capacitors. The recommended procedure is to place both a 0.1 μ F and a 1 μ F capacitor as close as physically possible to each power pin. The 0.1 μ F capacitor should be closest to the part (typically 5mm or closer).

4.2 Analog Power Conditioning

In order to obtain the best performance from the CS49400's internal PLL, the analog power supply PLLVDD must be as noise-free as possible. A ferrite bead and two capacitors should be used to filter the VDD to generate PLLVDD. This power scheme is shown in the typical connection diagrams.

4.3 Ground

For two layer circuit boards, care should be taken to have sufficient ground between the DSP and parts in which it will be interfacing (DACs, ADCs, S/PDIF Receivers, microcontrollers, and especially external memory). Insufficient ground can degrade noise margins between devices resulting in data integrity problems.

4.4 Pads

The CS49400 has two different I/O voltage levels. All signal pins not associated with the External SRAM/SDRAM memory interface operate from the 2.5V supply and are 3.3V tolerant. The external SRAM/SDRAM memory interface operates at 3.3V only. However, if the external memory interface is not used VDDSD1-4 may be connected to 2.5V.



12.2 100-Pin LQFP Package Pin Layout

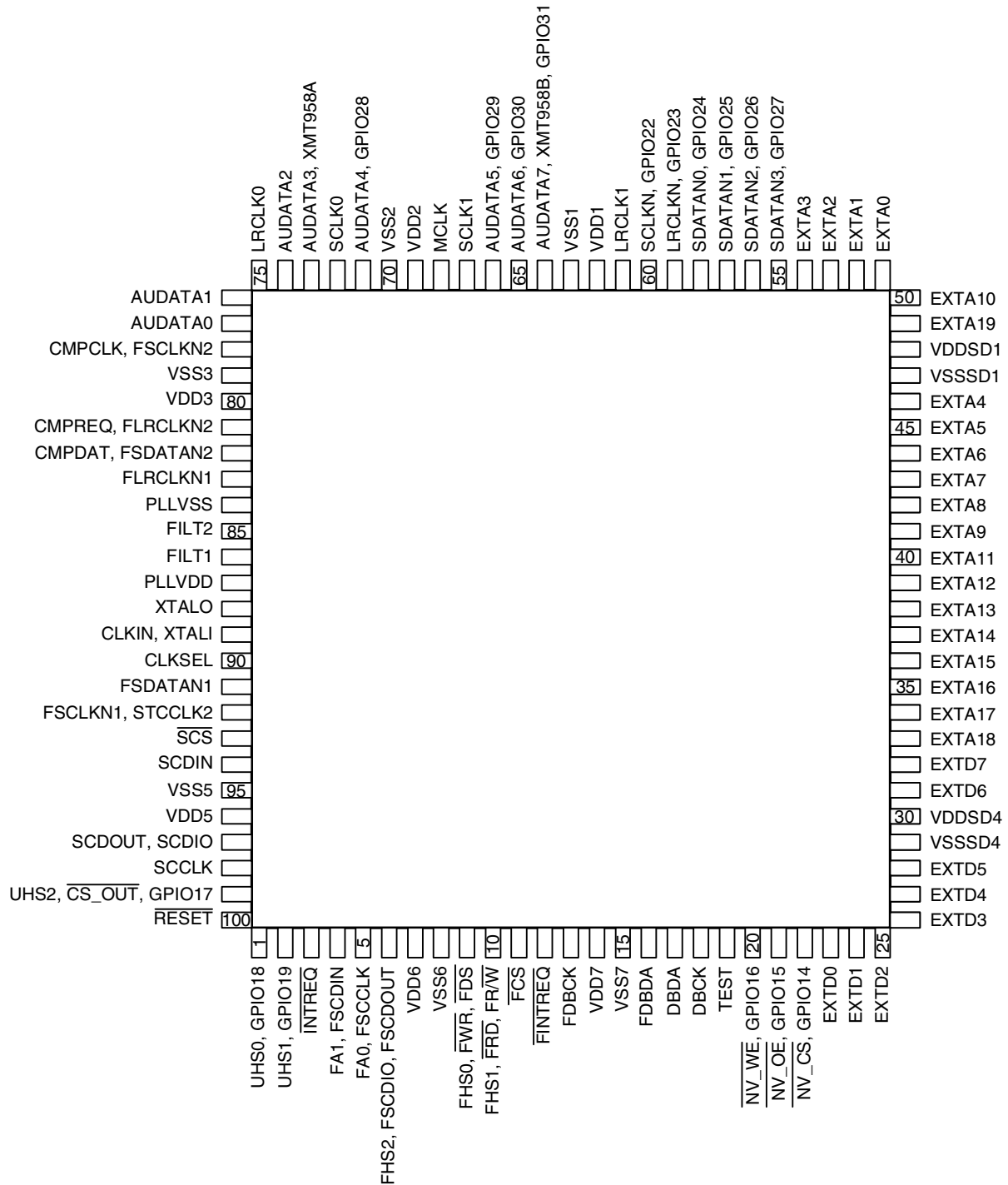

Figure 58. Pin Layout (100-Pin LQFP Package)



12.3 Pin Definitions

FILT1 — Phase-Locked Loop Filter

Connects to an external filter for the on-chip phase-locked loop.

FILT2 — Phase Locked Loop Filter

Connects to an external filter for the on-chip phase-locked loop.

CLKIN, XTALI — External Clock Input/Crystal Oscillator Input

CS49400 clock input. This pin accepts an external clock input signal that is used to drive the internal core logic. When in internal clock mode (CLKSEL == VSS), this input is connected to the internal PLL from which all internal clocks are derived. When in external clock mode (CLKSEL == VDD), this input is connected to the DSP clock. Alternatively, a 12.288 mHz crystal oscillator can be connected between XTALI and XTALO. *INPUT*

XTALO — Crystal Oscillator Output

Crystal oscillator output. *OUTPUT*

CLKSEL — DSP Clock Select

This pin selects the internal source clock. When CLKSEL is low, CLKIN is connected to the internal PLL from which all internal clocks are derived. When CLKSEL is high, the PLL is bypassed and the external clock directly drives all input logic. *INPUT*

FDAT7 — DSPAB Bidirectional Data Bus

FDAT6

FDAT5

FDAT4

FDAT3

FDAT2

FDAT1

FDAT0

In parallel host mode, these pins provide a bidirectional data bus to DSPAB. These pins have an internal pull-up.

BIDIRECTIONAL - Default: INPUT

FA0, FSCCLK — Host Parallel Address Bit Zero or Serial Control Port Clock

In parallel host mode, this pin serves as one of two address input pins used to select one of four parallel registers. In serial host mode, this pin serves as the serial control clock signal, specifically as the SPI clock input. *INPUT*



FA1, FSCDIN — Host Address Bit One or SPI Serial Control Data Input

In parallel host mode, this pin serves as one of two address input pins used to select one of four parallel registers. In SPI serial host mode, this pin serves as the data input. *INPUT*

FHS1, $\overline{\text{FRD}}$, $\overline{\text{FRW}}$ — Mode Select Bit 1 or Host Parallel Output Enable or Host Parallel R/W

DSPAB control port mode select bit 1. This bit is one of 3 control port select bits that are sampled on the rising edge of $\overline{\text{RESET}}$ to determine the control port mode of DSPAB. In Intel parallel host mode, this pin serves as the active-low data bus enable input. In Motorola parallel host mode, this pin serves as the read-high/write-low control input signal. In serial host mode, this pin can serve as the external memory active-low data-enable output signal. *BIDIRECTIONAL - Default: INPUT*

FHS0, $\overline{\text{FWR}}$, $\overline{\text{FDS}}$ — Mode Select Bit 0 or Host Write Strobe or Host Data Strobe

DSPAB control port mode select bit 0. This bit is one of 3 control port select bits that are sampled on the rising edge of $\overline{\text{RESET}}$ to determine the control port mode of DSPAB. In Intel parallel host mode, this pin serves as the active-low data-write-input strobe. In Motorola parallel host mode, this pin serves as the active-low data-strobe-input signal. In serial host mode, this pin can serve as the external-memory active-low write-enable output signal. *BIDIRECTIONAL - Default: INPUT*

$\overline{\text{FCS}}$ — Host Parallel Chip Select, Host Serial SPI Chip Select

In parallel host mode, this pin serves as the active-low chip-select input signal. In serial host SPI mode, this pin is used as the active-low chip-select input signal. *INPUT*

FHS2, FSCDIO, FSCDOUT — Mode Select Bit 2 or Serial Control Port Data Input and Output, Parallel Port Type Select

DSPAB control port mode select bit 2. This bit is one of 3 control port select bits that are sampled on the rising edge of $\overline{\text{RESET}}$ to determine the control port mode of DSPAB. In SPI mode this pin serves as the data output pin. In parallel host mode, this pin is sampled at the rising edge of $\overline{\text{RESET}}$ to configure the parallel host mode as an Intel type bus or as a Motorola type bus. *BIDIRECTIONAL - Default: INPUT*

$\overline{\text{FINTREQ}}$ — Control Port Interrupt Request

Open-drain interrupt-request output. This pin is driven low to indicate that the DSP has outgoing control data that should be read by the host.

OPEN DRAIN I/O - Requires 3.3K Ohm Pull-Up

FSCLKN1, STCLK2 — PCM Audio Input Bit Clock

Digital-audio bit clock input. FSCLKN1 operates asynchronously from all other DSPAB clocks. In master mode, FSCLKN1 is derived from DSPAB's internal clock generator. The active edge of FSCLKN1 can be programmed by the DSP.

BIDIRECTIONAL - Default: INPUT

FLRCLKN1 — PCM Audio Input Sample Rate Clock



Digital-audio frame clock input. FLRCLKN1 typically is run at the sampling frequency. FLRCLKN1 operates asynchronously from all other DSPAB clocks. The polarity of FLRCLKN1 for a particular subframe can be programmed by the DSP.

BIDIRECTIONAL - Default: INPUT

FSDATAN1 — PCM Audio Data Input One

Digital-audio data input that can accept from one compressed line or 2 channels of PCM data. FSDATAN1 can be sampled with either edge of FSCLKN1, depending on how FSCLKN1 has been configured. *INPUT*

CMPCLK, FSCLKN2 — PCM Audio Input Bit Clock

Digital-audio bit clock input. FSCLKN2 operates asynchronously from all other DSPAB clocks. The active edge of FSCLKN2 can be programmed by the DSP.

BIDIRECTIONAL - Default: INPUT

CMPDAT, FSDATAN2 — PCM Audio Data Input Number Two

Digital-audio data input that can accept either one compressed line or 2 channels of PCM data. FSDATAN2 can be sampled with either edge of FSCLKN2, depending on how FSCLKN2 has been configured.

BIDIRECTIONAL - Default: INPUT

FDBCK — Reserved

This pin is reserved and should be pulled up with an external 3.3k resistor. *INPUT*

FDBDA — Reserved

This pin is reserved and should be pulled up with an external 3.3k resistor.

BIDIRECTIONAL - Default: INPUT

PLLVDD — PLL Supply Voltage

2.5 V PLL supply.

PLLVSS — PLL Ground Voltage

PLL ground.

$\overline{\text{RESET}}$ — Master Reset Input

Asynchronous active-low master reset input. Reset should be low at power-up to initialize the DSP and to guarantee that the device is not active during initial power-on stabilization periods. At the rising edge of reset the host interface mode of DSPAB is selected contingent on the state of the FHS0, FHS1, and FHS2 pins. At the rising edge of reset the host interface mode of DSPC is selected contingent on the state of the UHS0, UHS1, and UHS2 pins. If reset is low all bidirectional pins are high-Z inputs. *INPUT*

TEST — Reserved



This should be tied low for normal operation. *INPUT*

MCLK — Audio Master Clock

Bidirectional master audio clock. As an output, MCLK provides a low jitter oversampling clock. MCLK supports all standard oversampling frequencies. *BIDIRECTIONAL - Default: INPUT*

SCLK0 — Audio Output Bit Clock

Bidirectional digital-audio output bit clock for AUDATA0, AUDATA1, AUDATA2, and AUDATA3. As an output, SCLK0 can provide 32 Fs, 64 Fs, 128 Fs, 256 Fs, or 512 Fs frequencies and is synchronous to MCLK. As an input, SCLK0 is independent of MCLK.

BIDIRECTIONAL - Default: INPUT

SCLK1 — Audio Output Bit Clock

Bidirectional digital-audio output bit clock for AUDATA4, AUDATA5, AUDATA6, and AUDATA7. As an output, SCLK1 can provide 32 Fs, 64 Fs, 128 Fs, 256 Fs, or 512 Fs frequencies and is synchronous to MCLK. As an input, SCLK1 is independent of MCLK.

BIDIRECTIONAL - Default: INPUT

LRCLK0 — Audio Output Sample Rate Clock

Bidirectional digital-audio output frame clock for AUDATA0, AUDATA1, AUDATA2, and AUDATA3. As an output, LRCLK0 can provide all standard output sample rates up to 192 kHz and is synchronous to MCLK. As an input, LRCLK0 is independent of MCLK.

BIDIRECTIONAL - Default: INPUT

LRCLK1 — Audio Output Sample Rate Clock

Bidirectional digital-audio output frame clock for AUDATA4, AUDATA5, AUDATA6, and AUDATA7. As an output, LRCLK1 can provide all standard output sample rates up to 192 kHz and is synchronous to MCLK. As an input, LRCLK1 is independent of MCLK.

BIDIRECTIONAL - Default: INPUT

AUDATA0 — Digital Audio Output 0

PCM digital-audio data output. *OUTPUT*

AUDATA1 — Digital Audio Output 1

PCM digital-audio data output. *OUTPUT*

AUDATA2 — Digital Audio Output 2

PCM digital-audio data output. *OUTPUT*

AUDATA3, XMT958A — Digital Audio Output 3, S/PDIF Transmitter



CMOS level output that outputs a biphase-mark encoded (S/PDIF) IEC60958 signal or digital audio data which is capable of carrying two channels of PCM digital audio. *OUTPUT*

AUDATA4, GPIO28 — Digital Audio Output 4, General Purpose I/O

PCM digital-audio data output. This pin can act as a general-purpose input or output that can be individually configured and controlled by DSPC. *BIDIRECTIONAL - Default: OUTPUT*

AUDATA5, GPIO29 — Digital Audio Output 5, General Purpose I/O

PCM digital-audio data output. This pin can act as a general-purpose input or output that can be individually configured and controlled by DSPC. *BIDIRECTIONAL - Default: OUTPUT*

AUDATA6, GPIO30 — Digital Audio Output 6, General Purpose I/O

PCM digital-audio data output. This pin can act as a general-purpose input or output that can be individually configured and controlled by DSPC. *BIDIRECTIONAL - Default: OUTPUT*

AUDATA7, XMT958B, GPIO31 — Digital Audio Output 7, S/PDIF Transmitter, General Purpose I/O

CMOS level output that contains a biphase-mark encoded (S/PDIF) IEC60958 signal or digital audio data which is capable of carrying two channels of PCM digital audio. This pin can also act as a general-purpose input or output that can be individually configured and controlled by DSPC. *BIDIRECTIONAL - Default: OUTPUT*

DBCK — Debug Clock

Must be tied high to 3.3k ohm resistor. *INPUT*

DBDA — Debug Data

Must be tied high to 3.3k ohm resistor. *BIDIRECTIONAL - Default: INPUT*

SLCKN, GPIO22 — PCM Audio Input Bit Clock, General Purpose I/O

Digital-audio bit clock that is an input. SCLKN operates asynchronously from all other DSPAB clocks. The active edge of SCLKN can be programmed by the DSP. This pin can act as a general-purpose input or output that can be individually configured and controlled by DSPC. *BIDIRECTIONAL - Default: INPUT*

LRCLKN, GPIO23 — PCM Audio Input Sample Rate Clock, General Purpose I/O

Digital-audio frame clock input. LRCLKN operates asynchronously from all other DSPAB clocks. The polarity of LRCLKN for a particular subframe can be programmed by the DSP. This pin can act as a general-purpose input or output that can be individually configured and controlled by DSPC. *BIDIRECTIONAL - Default: INPUT*

SDATAN0, GPIO24 — PCM Audio Input Data, General Purpose I/O

Digital-audio PCM data input. This pin can act as a general-purpose input or output that can be individually configured and controlled by DSPC. *BIDIRECTIONAL - Default: INPUT*

SDATAN1, GPIO25 — PCM Audio Input Data, General Purpose I/O



Digital-audio PCM data input. This pin can act as a general-purpose input or output that can be individually configured and controlled by DSPC. *BIDIRECTIONAL - Default: INPUT*

SDATAN2, GPIO26 — PCM Audio Input Data, General Purpose I/O

Digital-audio PCM data input. This pin can act as a general-purpose input or output that can be individually configured and controlled by DSPC. *BIDIRECTIONAL - Default: INPUT*

SDATAN3, GPIO27 — PCM Audio Input Data, General Purpose I/O

Digital-audio PCM data input. This pin can act as a general-purpose input or output that can be individually configured and controlled by DSPC. *BIDIRECTIONAL - Default: INPUT*

SCS — Host Serial SPI Chip Select

SPI mode active-low chip-select input signal. *INPUT*

SCCLK — Serial Control Port Clock

This pin serves as the serial SPI clock input. *INPUT*

SCDIN — SPI Serial Control Data Input

In SPI mode this pin serves as the data input pin. *INPUT*

SCDOUT, SCDIO — Serial Control Port Data Input and Output

In SPI mode this pin serves as the data output pin. *BIDIRECTIONAL - Default: OUTPUT in SPI mode*

INTREQ — Control Port Interrupt Request

Open-drain interrupt-request output. This pin is driven low to indicate that DSPC has outgoing control data and should be serviced by the host.

OPEN DRAIN I/O - Requires 3.3K Ohm Pull-Up



HDATA7, GPIO7 — DSPC Bidirectional Data Bus, General Purpose I/O

HDATA6, GPIO6

HDATA5, GPIO5

HDATA4, GPIO4

HDATA3, GPIO3

HDATA2, GPIO2

HDATA1, GPIO1

HDATA0, GPIO0

In parallel host mode, these pins provide a bidirectional data bus. These pins can also act as general purpose input or output pins that can be individually configured and controlled by DSPC. These pins have an internal pull-up. *BIDIRECTIONAL - Default: INPUT*

A0, GPIO13 — Host Parallel Address Bit 0, General Purpose I/O

In parallel host mode, this pin serves as the LS Bit of a two bit address input used to select one of four parallel registers. This pin can act as a general-purpose input or output that can be individually configured and controlled by DSPC. *BIDIRECTIONAL - Default: INPUT*

A1, GPIO12 — Host Address Bit 1, General Purpose I/O

In parallel host mode, this pin serves as the MS Bit of a two bit address input used to select one of four parallel registers. This pin can act as a general-purpose input or output that can be individually configured and controlled by DSPC. *BIDIRECTIONAL - Default: INPUT*

\overline{RD} , $\overline{R/W}$, GPIO11 — Host Parallel Output Enable, Host Parallel $\overline{R/W}$, General Purpose I/O

In Intel parallel host mode, this pin serves as the active-low data bus enable input. In Motorola parallel host mode, this pin serves as the read-high/write-low control input signal. This pin can act as a general-purpose input or output that can be individually configured and controlled by DSPC. This pin has an internal pull-up. *BIDIRECTIONAL - Default: INPUT*

\overline{WR} , \overline{DS} , GPIO10 — Host Write Strobe, Host Data Strobe, General Purpose I/O

In Intel parallel host mode, this pin serves as the active-low data bus enable input. In Motorola parallel host mode, this pin serves as the read-high/write-low control input signal. In serial host mode, this pin can serve as a general purpose input or output bit. This pin can act as a general-purpose input or output that can be individually configured and controlled by DSPC. This pin has an internal pull-up.
BIDIRECTIONAL - Default: INPUT

\overline{CS} , GPIO9 — Host Parallel Chip Select, General Purpose I/O

In parallel host mode, this pin serves as the active-low chip-select input signal. This pin can act as a general-purpose input or output that can be individually configured and controlled by DSPC. This pin has an internal pull-up. *BIDIRECTIONAL - Default: INPUT*



HINBSY, GPIO8 — Input Host Message Status, General Purpose I/O

This pin indicates that serial or parallel communication data written to the DSP has not been read yet. This pin can act as a general-purpose input or output that can be individually configured and controlled by DSPC. This pin has an internal pull-up. *BIDIRECTIONAL - Default: OUTPUT*

SD_DATA15, EXTA18 — SDRAM Data Bus, SRAM External Address Bus

SD_DATA14, EXTA17

SD_DATA13, EXTA16

SD_DATA12, EXTA15

SD_DATA11, EXTA14

SD_DATA10, EXTA13

SD_DATA9, EXTA12

SD_DATA8, EXTA11

SDRAM data bus 15:8. SRAM external address bus 18:11. *OUTPUT*

SD_DATA7, EXTD7 — SDRAM Data Bus, SRAM External Data Bus

SD_DATA6, EXTD6

SD_DATA5, EXTD5

SD_DATA4, EXTD4

SD_DATA3, EXTD3

SD_DATA2, EXTD2

SD_DATA1, EXTD1

SD_DATA0, EXTD0

SDRAM data bus 7:0. SRAM external data bus 7:0. *BIDIRECTIONAL - Default: INPUT*

SD_ADDR10, EXTA10 — SDRAM Address Bus, SRAM External Address Bus

SD_ADDR9, EXTA9

SD_ADDR8, EXTA8

SD_ADDR7, EXTA7

SD_ADDR6, EXTA6

SD_ADDR5, EXTA5

SD_ADDR4, EXTA4

SD_ADDR3, EXTA3

SD_ADDR2, EXTA2

SD_ADDR1, EXTA1

SD_ADDR0, EXTA0

SDRAM address bus 10:0. SRAM external address bus 10:0. *OUTPUT*

**SD_CLK_OUT — SDRAM Clock Output**SDRAM clock output. *OUTPUT***SD_CLK_IN — SDRAM Re-timing Clock Input**SDRAM re-timing clock input. *INPUT***SD_CLK_EN — SDRAM Clock Enable**SDRAM clock enable. *OUTPUT***SD_BA, EXTA19 — SDRAM Bank Address Select, SRAM External Address Bus**SDRAM bank address select. SRAM external address bus 19. *OUTPUT* **$\overline{\text{SD_CS}}$ — SDRAM Chip Select**SDRAM chip select. *OUTPUT* **$\overline{\text{SD_RAS}}$ — SDRAM Row Address Strobe**SDRAM row address strobe. *OUTPUT* **$\overline{\text{SD_CAS}}$ — SDRAM Column Address Strobe**SDRAM column address strobe. *OUTPUT* **$\overline{\text{SD_WE}}$ — SDRAM Write Enable**SDRAM write enable. *OUTPUT***SD_DQM1 — SDRAM Data Mask 1**SDRAM data mask 1. *OUTPUT***SD_DQM0 — SDRAM Data Mask 2**SDRAM data mask 0. *OUTPUT* **$\overline{\text{NV_CS}}$, GPIO14 — SRAM Chip Select, General Purpose I/O**SRAM/Flash chip select. This pin can act as a general-purpose input or output that can be individually configured and controlled by DSPC. *BIDIRECTIONAL - Default: OUTPUT* **$\overline{\text{NV_OE}}$, GPIO15 — SRAM Output Enable, General Purpose I/O**SRAM/Flash output enable. This pin can act as a general-purpose input or output that can be individually configured and controlled by DSPC. *BIDIRECTIONAL - Default: OUTPUT*



NV_WE, GPIO16 — SRAM Write Enable, General Purpose I/O

SRAM/Flash write enable. This pin can act as a general-purpose input or output that can be individually configured and controlled by DSPC. *BIDIRECTIONAL - Default: OUTPUT*

UHS2, CS_OUT, GPIO17 — Mode Select Bit 2, External Serial Memory Chip Select, General Purpose I/O

DSPC control port mode select bit 2. This pin is sampled at the rising edge of $\overline{\text{RESET}}$ and is one of three pins used to select the control port mode. In serial control port mode, this pin can serve as an output to provide the chip-select for a serial EEPROM. This pin can act as a general-purpose input or output that can be individually configured and controlled by DSPC. *BIDIRECTIONAL - Default: INPUT*

UHS0, GPIO18 — Mode Select Bit 0, General Purpose I/O

DSPC control port mode select bit 0. This pin is sampled at the rising edge of $\overline{\text{RESET}}$ and is one of three pins used to select the control port mode. This pin can act as a general-purpose input or output that can be individually configured and controlled by DSPC. *BIDIRECTIONAL - Default: INPUT*

UHS1, GPIO19 — Mode Select Bit 1, General Purpose I/O

DSPC control port mode select bit 1. This pin is sampled at the rising edge of $\overline{\text{RESET}}$ and is one of three pins used to select the control port mode. This pin can act as a general-purpose input or output that can be individually configured and controlled by DSPC. *BIDIRECTIONAL - Default: INPUT*

GPIO20 — General Purpose I/O

This pin can act as a general-purpose input or output that can be individually configured and controlled by DSPC. This pin has an internal pull-up. *BIDIRECTIONAL - Default: INPUT*

GPIO21 — General Purpose I/O

This pin can act as a general-purpose input or output that can be individually configured and controlled by DSPC. This pin has an internal pull-up. *BIDIRECTIONAL - Default: INPUT*

VDD[7:1] — 2.5V Supply Voltage

2.5V supply voltage.

VSS — 2.5V Ground

2.5V ground.



NC[5:1] — No Connect

Recommended tie to ground.

VDDSD[4:1] — 3.3V SDRAM/SRAM/EPROM Interface Supply

3.3V SDRAM/SRAM/EPROM supply.

VSSSD — 3.3V SDRAM/SRAM/EPROM Interface Ground

3.3V ground.

BLOCK DIAGRAM

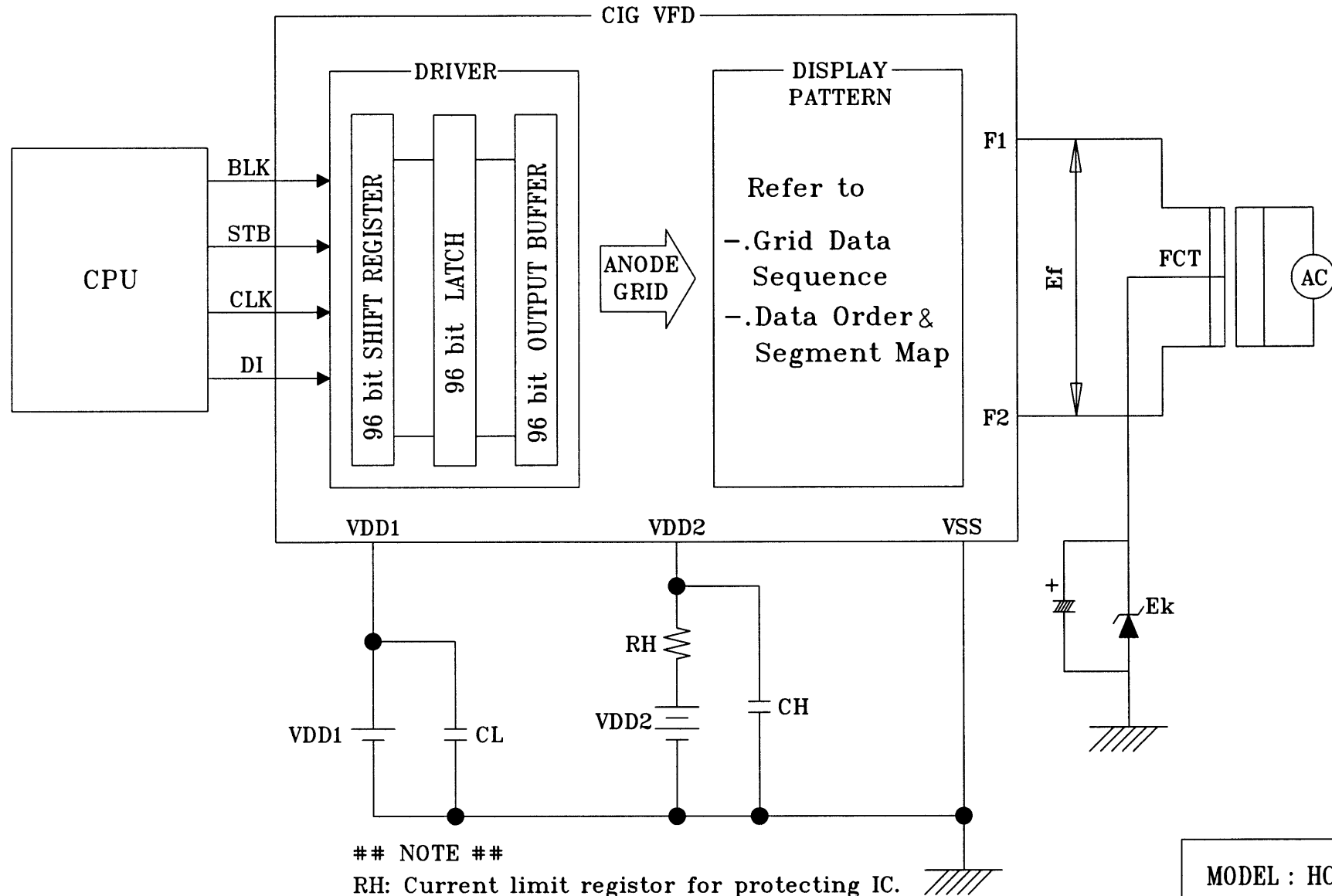

NOTE

RH: Current limit resistor for protecting IC.

CH,CL: Low pass filter for noise filtering.

RH: 22Ω, CH: 0.1 μF, CL: 0.1 μF

FCT: Filament is center-tab grounded.

MODEL : HCA-18ML01
 BLOCK DIAGRAM
 Rev. ① 20-Feb-2003

OUTER DIMENSIONS

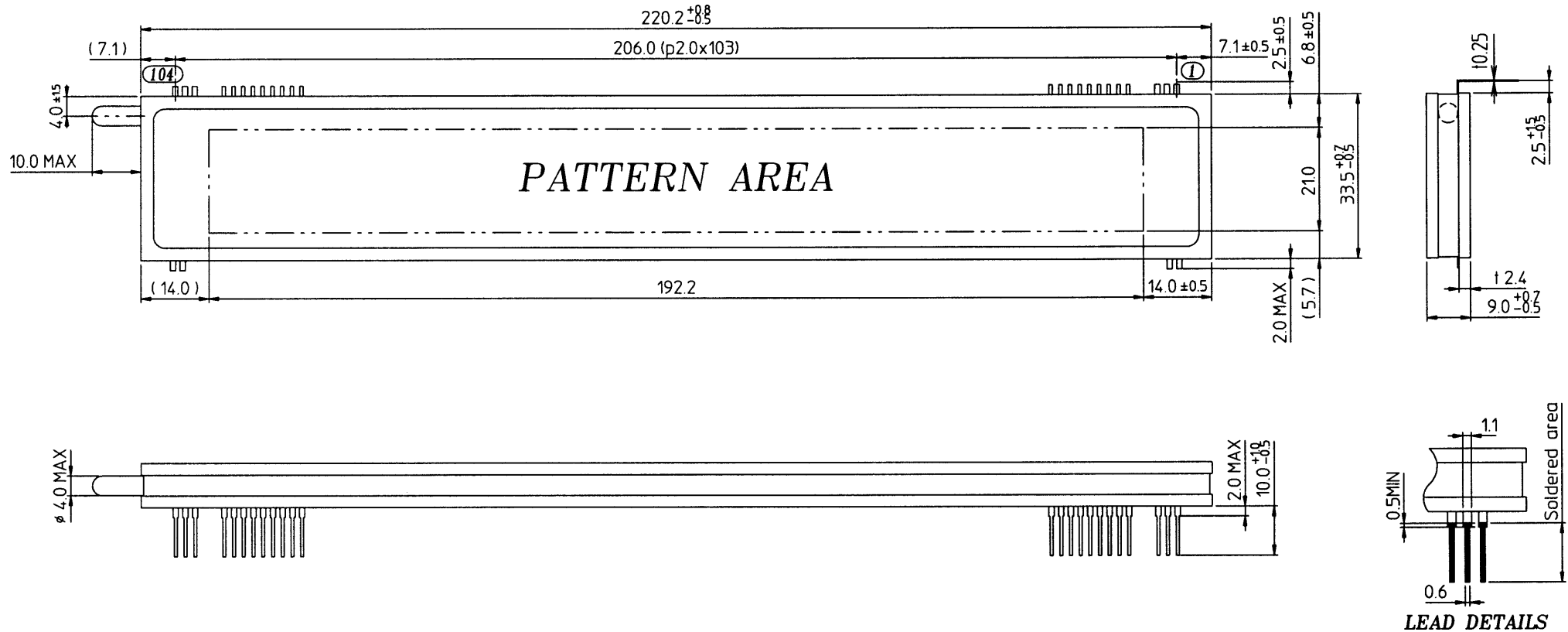

PIN CONNECTION

PIN NO.	104	103	102	101	100	99	98	97	96	95	94	93	92	91	90~15	14~6	5	4	3	2	1
CONNECTION	F2	F2	F2	NP	NP	VDD2	VSS	VSS	CLK	DO	DI	BLK	STB	VDD1	NP	NC	NP	NP	F1	F1	F1

***Notes**

Fn : Filament Pin

* DO(Serial data output) : Be left open if not used.

NP : No Pin

NC : No Connection Pin

MODEL : HCA-18ML01
 OUTER DIMENSIONS
 Rev. ① 20-Feb-2003



2-CHANNEL ELECTRONIC VOLUME

■ GENERAL DESCRIPTION

NJW1159 is a two channel electronic volume IC. It is included output buffer amplifier and also resistor output terminal for using external amplifier to customize for your application. These functions are controlled by three-wired serial data. And the chip selector is available for using four chips on same serial bus line. It's available for two-channel stereo and or multi-channel audio volume.

■ PACKAGE OUTLINE



NJW1159V

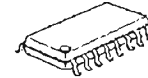

NJW1159M

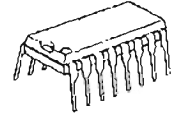

NJW1159D

■ FEATURES

- Operating Voltage
- Three-Wired Serial Data Control
- Chip Selector
- Volume
- Bi-CMOS Technology
- Package Outline

± 4.5 to ± 7.5 V

available for using four chips on same serial bus line.
0 to -95dB/1dBstep, MUTE

SSOP16, DMP16, DIP16

■ BLOCK DIAGRAM

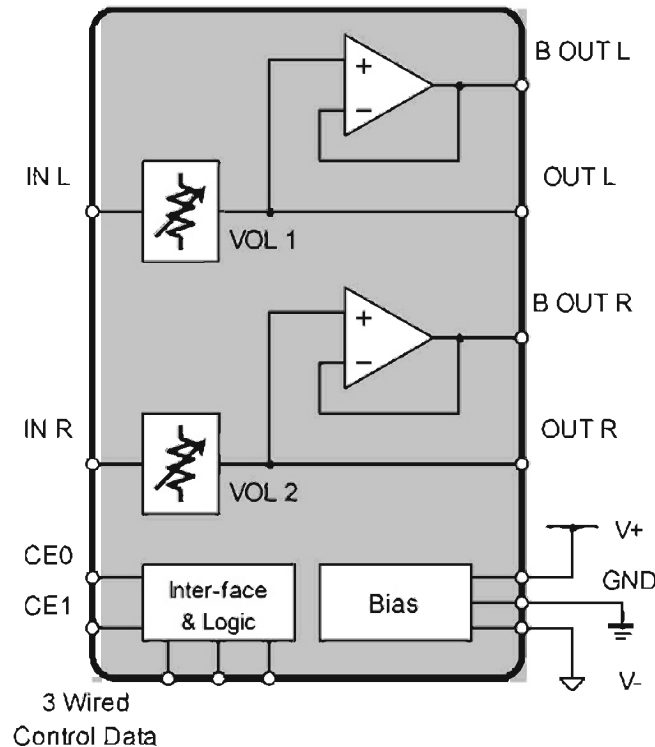

NJW1159

■ PIN ASSIGNMENT

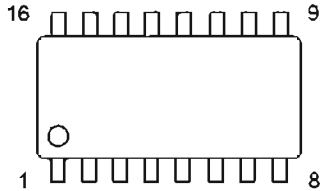

No.	Symbol	Function
1	OUTL	Lch External Opamp Input Connection Terminal
2	BOUTL	Lch Output
3	VDD_OUT	Internal VDD Noise Rejection Capacitor Terminal
4	BOUTr	Rch Output
5	OUTr	Rch External Opamp Input Connection Terminal
6	VSS_OUT	Internal VSS Noise Rejection Capacitor Terminal
7	V+	+ Power supply voltage input
8	V-	- Power supply voltage input
9	INL	Lch Input
10	INR	Rch Input
11	CE0	Chip Enable Terminal 0
12	CE1	Chip Enable Terminal 1
13	DATA	Control data signal input
14	CLOCK	Clock signal input
15	LACTH	Latch signal input
16	GND	Ground

■ ABSOLUTE MAXIMUM RATING (Ta=25°C)

PARAMETER	SYMBOL	RATING	UNIT
Power Supply Voltage	V^+ / V^-	+8/-8	V
Maximum Input Voltage	V_{IM}	$V^+ / V^{(-)}$	V
Power Dissipation	P_D	SSOP16 ; 300 DMP16 ; 300 DIP16 ; 500	mW
Operating Temperature Range	T_{opr}	-40 to +85	°C
Storage Temperature Range	T_{stg}	-40 to +125	°C

(*) For the maximum input voltage less than V^+ / V^-

■ ELECTRICAL CHARACTERISTICS (Ta=25°C, $V^+ / V^- = +7V / -7V$, $R_L = 47k\Omega$)

PARAMETER	SYMBOL	TEST CONDITION	MIN.	TYP.	MAX.	UNIT
◆ Power Supply						
Operating Voltage 1	V+		4.5	7.0	7.5	V
Operating Voltage 2	V-		-7.5	-7.0	-4.5	V
Supply Current 1	I_{CC}	No signal	-	4.5	9.0	mA
Supply Current 2	I_{EE}	No signal	-	4.5	9.0	mA
◆ Input/Output Characteristics (BOUTr : 2pin, BOUTr : 4pin)						
Maximum Output Voltage	V_{OM}	f=1kHz, THD=1% Volume=0dB	3.0	4.0	-	Vrms
Voltage Gain	G_V	$V_{IN}=1V_{rms}$, f=1kHz Volume=0dB	-0.5	0	0.5	dB
Channel Gain Balance 1	ΔG_{V1}	$V_{IN}=1V_{rms}$, f=1kHz Volume=0dB	-0.5	0	0.5	dB
Channel Gain Balance 2	ΔG_{V2}	$V_{IN}=1V_{rms}$, f=1kHz Volume=-60dB	-1.0	0	1.0	dB
Maximum Attenuation	A_{TT}	$V_{IN}=1V_{rms}$, f=1kHz Volume=-95dB, A-weight	-	-95	-	dB
Mute Level	Mute	$V_{IN}=1V_{rms}$, f=1kHz Volume=Mute, A-weight	-	-110	-	dB
Output Noise Voltage	V_{NO}	Volume=0dB, $R_g=0\Omega$, A-weight	-	-105 (5.6 μ)	-95 (17.8 μ)	dBV (Vrms)
Total Harmonic Distortion	THD	$V_o=1V_{rms}$, f=1kHz, Volume=0dB, BW=400-30kHz	-	0.005	0.05	%
Channel Separation	CS	$V_o=1V_{rms}$, f=1kHz, A-weight Volume=0dB, $R_g=0\Omega$	-	-100	-90	dB



HCF4053B

TRIPLE 2-CHANNEL ANALOG MULTIPLEXER/DEMULTIPLEXER

- LOW "ON" RESISTANCE : 125Ω (Typ.)
OVER 15V p.p SIGNAL-INPUT RANGE FOR
 $V_{DD} - V_{EE} = 15V$
- HIGH "OFF" RESISTANCE : CHANNEL
LEAKAGE $\pm 100pA$ (Typ.) at $V_{DD} - V_{EE} = 18V$
- BINARY ADDRESS DECODING ON CHIP
- HIGH DEGREE OF LINEARITY : < 0.5%
DISTORTION TYP. at $f_{IS} = 1KHz$, $V_{IS} = 5 V_{pp}$,
 $V_{DD} - V_{SS} \geq 10V$, $R_L = 10K\Omega$
- VERY LOW QUIESCENT POWER
DISSIPATION UNDER ALL DIGITAL
CONTROL INPUT AND SUPPLY
CONDITIONS : 0.2 μW (Typ.)
at $V_{DD} - V_{SS} = V_{DD} - V_{EE} = 10V$
- MATCHED SWITCH CHARACTERISTICS :
 $R_{ON} = 5\Omega$ (Typ.) FOR $V_{DD} - V_{EE} = 15V$
- WIDE RANGE OF DIGITAL AND ANALOG
SIGNAL LEVELS : DIGITAL 3 to 20,
ANALOG TO 20V p.p.
- QUIESCENT CURRENT SPECIF. UP TO 20V
- 5V, 10V AND 15V PARAMETRIC RATINGS
- INPUT LEAKAGE CURRENT
 $I_l = 100nA$ (MAX) AT $V_{DD} = 18V$ $T_A = 25^\circ C$
- 100% TESTED FOR QUIESCENT CURRENT
- MEETS ALL REQUIREMENTS OF JEDEC
JESD13B " STANDARD SPECIFICATIONS
FOR DESCRIPTION OF B SERIES CMOS
DEVICES"

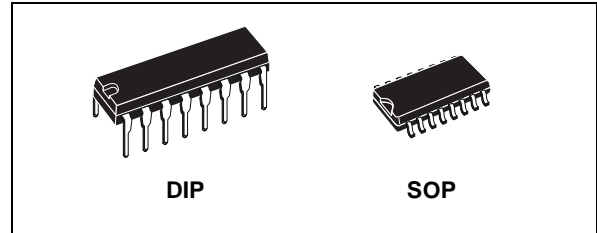

ORDER CODES

PACKAGE	TUBE	T & R
DIP	HCF4053BEY	
SOP	HCF4053BM1	HCF4053M013TR

technology available in DIP and SOP packages. The HCF4053B analog multiplexer/demultiplexer is a digitally controlled analog switch having low ON impedance and very low OFF leakage current. This multiplexer circuit dissipate extremely low quiescent power over the full $V_{DD} - V_{SS}$ and $V_{DD} - V_{EE}$ supply voltage range, independent of the logic state of the control signals.

When a logic "1" is present at the inhibit input terminal all channel are off. This device is a triple 2-channel multiplexer having three separate digital control inputs, A, B, and C, and an inhibit input. Each control input selects one of a pair of channels which are connected in a single pole double-throw configuration.

DESCRIPTION

The HCF4053B is a monolithic integrated circuit fabricated in Metal Oxide Semiconductor

PIN CONNECTION

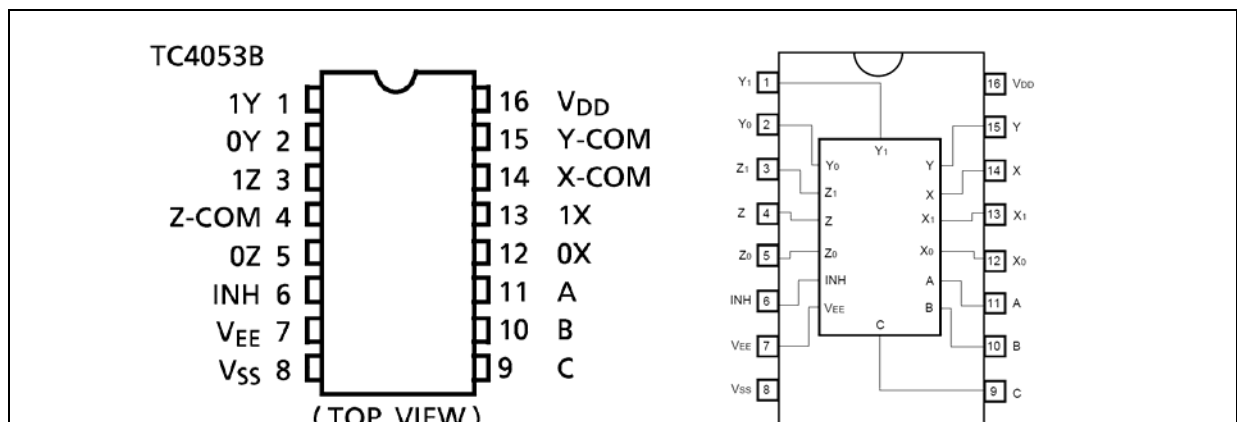

October 2002

HCF4053B

INPUT EQUIVALENT CIRCUIT

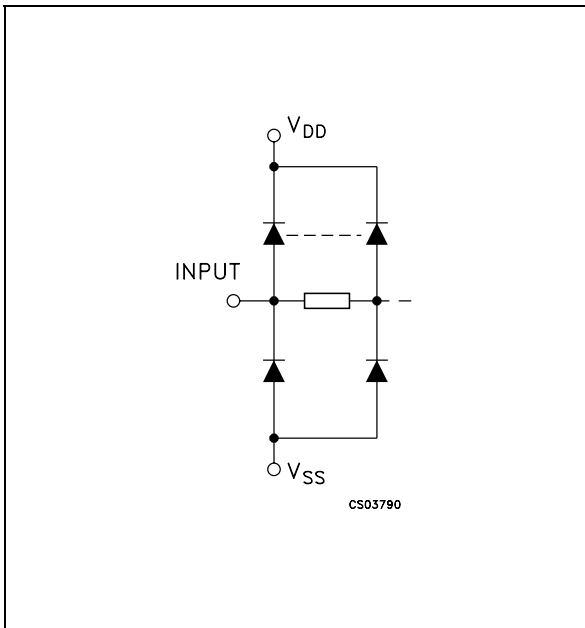

PIN DESCRIPTION

PIN No	SYMBOL	NAME AND FUNCTION
11, 10, 9	A, B, C	Binary Control Inputs
6	INH	Inhibit Inputs
12, 13, 2, 1, 5, 3	IN/OUT	ax,ay,bx,by,cx,cy Input/Output
14	OUT/IN	ax or ay
15	OUT/IN	bx or by
4	OUT/IN	cx or cy
7	V _{EE}	Supply Voltage
8	V _{SS}	Negative Supply Voltage
16	V _{DD}	Positive Supply Voltage

TRUTH TABLE

INHIBIT	C or B or A	
0	0	ax or bx or cx
0	1	ay or by or cy
1	X	NONE

X : Don't Care

FUNCTIONAL DIAGRAM

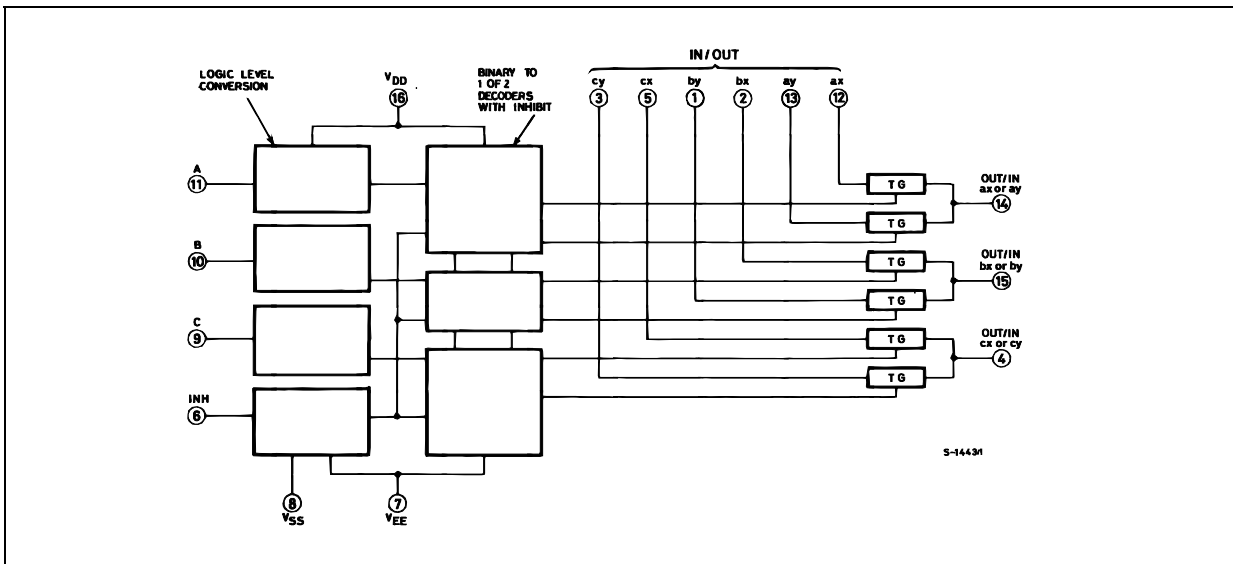

TOSHIBA**TA1270BF**

TENTATIVE TOSHIBA BIPOLAR LINEAR INTEGRATED CIRCUIT SILICON MONOLITHIC

TA1270BF

PAL / NTSC VIDEO AND CHROMA SYNC PROCESSING SYSTEM FOR PIP / POP / PAP

TA1270BF is a PAL / NTSC color TV signal processor IC suitable for PIP / POP / PAP. The IC integrates video and chroma sync processor circuits. It comes in a 48pin flat package.

The video block uses a chroma trap, the chroma block a PAL / NTSC automatic identifier circuit, and the sync processor block a 50 / 60 Hz automatic identifier circuit. The PAL demodulator circuit contains a baseband signal processor, making the circuit adjustment free.

The TA1270BF incorporates an I²C bus, enabling control to be set via the bus line.

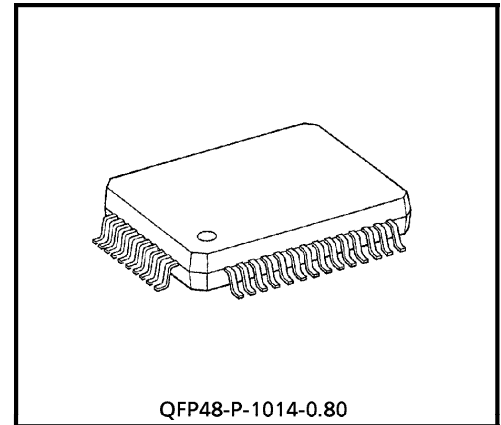

Weight : 0.83 g (Typ.)

FEATURES

Video block

- Chroma trap
- Y delay line
- Sub contrast adjustment (± 3 dB)

CHROMA block

- UV / CbCr demodulation for NTSC ; UV demodulation for PAL
- Tint control
- PAL demodulation baseband signal processing
- PAL / NTSC automatic identification
- Sub color adjustment (± 3 dB)

Sync processor block

- High-performance sync separator circuit
- Adjustment-free horizontal and vertical oscillator circuit using count down method
- 50 / 60 Hz automatic identifier circuit

Switch block

- High-speed switcher circuit
- YUV or RGB input
- Built-in RGB matrix circuit
- YUV or RGB output

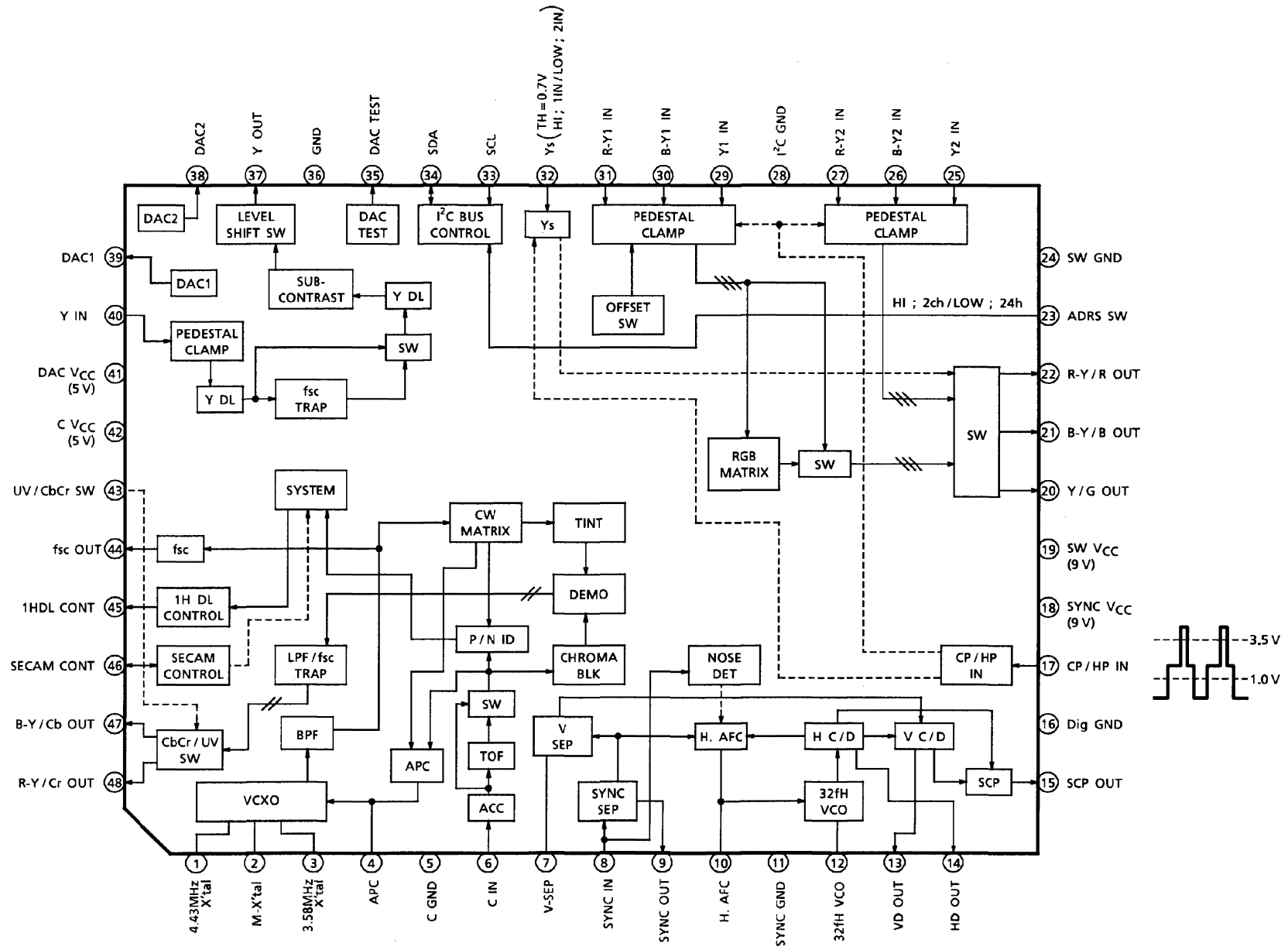

BLOCK DIAGRAM

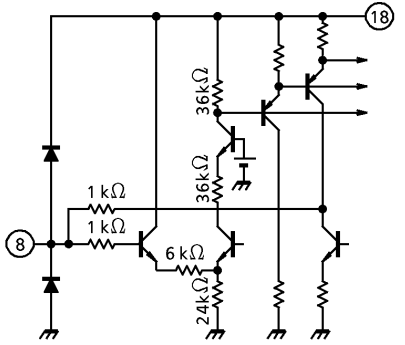
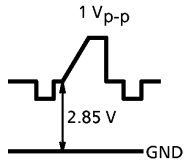
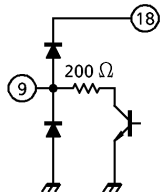
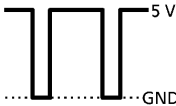
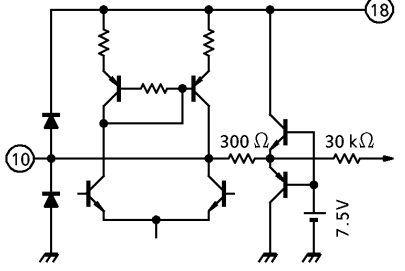
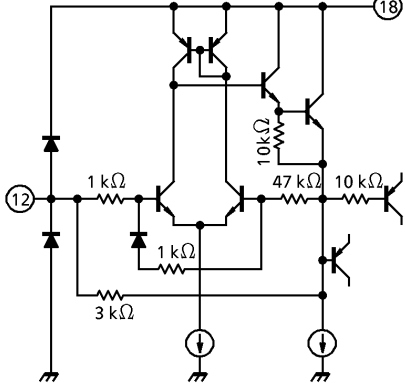
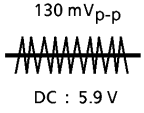

PIN FUNCTION

PIN No.	PIN NAME	FUNCTION	INTERFACE	INPUT / OUTPUT SIGNAL
1 2 3	X'tal-1 X'tal-2 X'tal-3	Connect crystal. Serial capacitance can vary oscillator frequency f_0 ; parallel capacitance can vary oscillator adjustment range.		DC 4.0 V 90 mV _{p-p}
4	APC filter	Connect APC filter for CHROMA demodulation. The voltage of this pin determines the VCXO oscillator frequency.		DC
5	C GND	CHROMA processor GND pin	—	—
6	CHROMA input	CHROMA input pin. Input CHROMA signal after Y/C separation.		Burst signal : 300 mV _{p-p} 2.5 V GND
7	V-SEP	Connect vertical sync separation filter.		DC 6.4 V

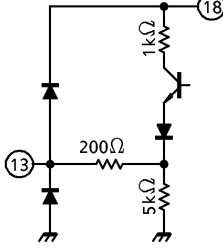
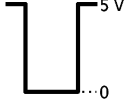
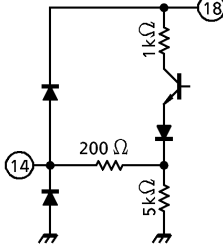
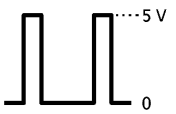
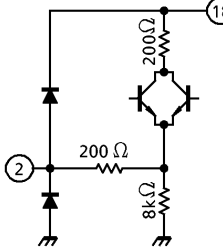
PIN No.	PIN NAME	FUNCTION	INTERFACE	INPUT / OUTPUT SIGNAL
8	Sync input	Sync separator circuit input pin. Input via the clamp capacitor.		
9	Sync output	Outputs sync signal separated using the sync separator circuit. Open collector output. Connect a pull-up resistor.		
10	AFC filter	Connect a horizontal AFC filter. The voltage of this pin determines the horizontal output frequency.		DC
11	SYNC GND	Sync processor GND pin	—	—
12	32 fH VCO	Connect a ceramic oscillator for horizontal oscillation. Use a CSB503F30 oscillator manufactured by Murata Mfg Co., Ltd.		

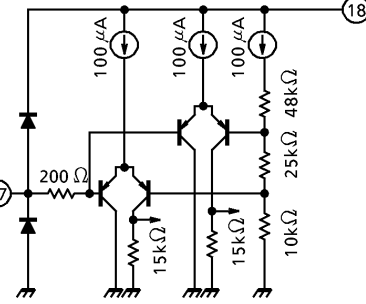
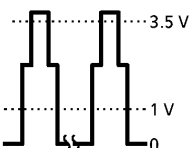
PIN No.	PIN NAME	FUNCTION	INTERFACE	INPUT / OUTPUT SIGNAL
13	VP output	Vertical pulse output pin		
14	HD output	Outputs HD pulse processed by the AFC. HD output phase or pulse width can be changed by bus setting.		
15	SCP output	Outputs sand castle pulse (SCP). The output signals are clamp pulse, horizontal blanking pulse, and vertical blanking pulse. The minimum load resistance is 3 kΩ.		
16	Dig GND	Logic block GND pin	—	—
17	CP / HP input	Input pin for CP / HP pulse used to operate the SW circuit. CP is used as clamp pulse ; HP as blanking pulse.		
18	SYNC VCC	VCC pins for sync processor block and SW block.	—	—
19	SW VCC	Connect 9 V (Typ.).	—	—

TOSHIBA**TA1270BF**

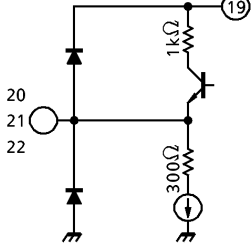
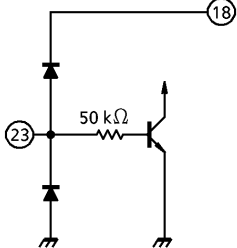
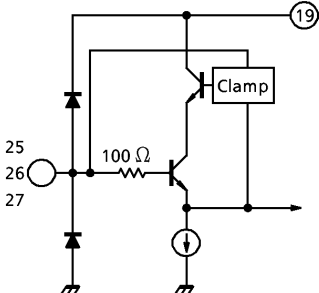
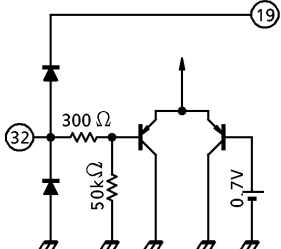
PIN No.	PIN NAME	FUNCTION	INTERFACE	INPUT / OUTPUT SIGNAL
20 21 22	Y/G output B-Y/B output R-Y/R output	Output Y/B-Y/R-Y or R/G/B. YUV/RGB output is switched by bus setting.		
23	ADRS SW	Pin used to switch slave addresses. GND — 24H, VCC — 2CH		2CH — 0.7 V 24H — GND
24	SW GND	Switch block GND pin	—	—
25 26 27	Y2 input B-Y2 input R-Y2 input (YUV2)	Y2/B-Y2/R-Y2 (YUV2 input) or R2/G2/B2 input pin. Input via capacitor used for clamp operation.		
28	I ² C GND	I ² C block GND pin	—	—
29 30 31	Y1 input B-Y1 input R-Y1 input (YUV1)	Y1/B-Y1/R-Y1 (YUV1 input) or R1/G1/B1 input pin. Input via capacitor used for clamp operation.	Same as those for pins 25, 26 and 27	
32	Ys	High-speed switch for switching input pins 25, 26, and 27 (YUV2) and input pins 29, 30, and 31 (YUV1). The threshold is 0.7 V.		YUV1 — 0.7 V YUV2 — GND

PIN No.	PIN NAME	FUNCTION	INTERFACE	INPUT / OUTPUT SIGNAL
33	SCL	I ² C Bus SCL pin		—
34	SDA	I ² C Bus SDA pin		—
35	DAC TEST	DAC monitor pin for IC shipping inspection.		—
36	GND	GND pin	—	—
37	Y output	Outputs Y signal which passed fsc trap (trap is set on or off by Bus) and Y delay line circuit.		
38 39	DAC2 DAC1	1 bit DAC output pins		—

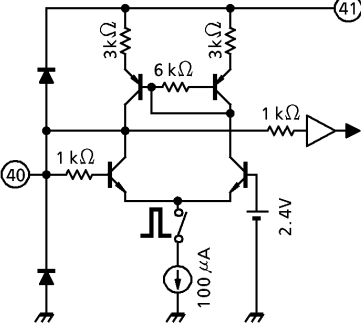
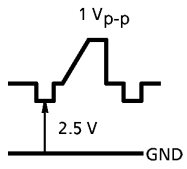
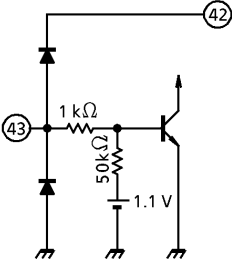
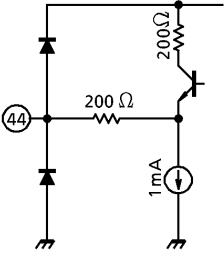
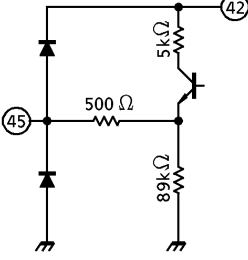
PIN No.	PIN NAME	FUNCTION	INTERFACE	INPUT / OUTPUT SIGNAL
40	Y input	Composite video signal or Y signal input pin. Input via the clamp capacitor.		
41 42	DAC V _{CC} C V _{CC}	V _{CC} pins for DAC block and CHROMA processing block. Connect 5 V (Typ.).	—	—
43	UV / CbCr SW	UV / CbCr demodulation switch. OPEN — UV GND — CbCr CbCr demodulation is effective for NTSC only.		<p>UV — 0.7 V CbCr — 0</p>
44	fsc output	Outputs crystal oscillator fsc. The pin voltage goes high only when 3.58NTSC is received.		<p>AC ; 0.6 V_{p-p} DC ; 3.58NTSC — 3.2 V OTHERS — 1.4 V</p>
45	1HDL CONT	Outputs PAL / SECAM / NTSC identification result. Adjust to DC and connect output to 1H DL IC.		<p>4.3 V ; PAL 2.5 V ; SECAM 0 V ; NTSC</p>

TOSHIBA**TA1270BF**

PIN No.	PIN NAME	FUNCTION	INTERFACE	INPUT / OUTPUT SIGNAL
46	SECAM CONT	I/O pin used to control SECAM demodulator IC. If 250 μ A or more flows from this pin, SECAM is determined.		At PAL / NTSC : 4.0 V At SECAM (Black and white) : 0.75 V
47	B-Y / Cb output	Outputs B-Y (U) signal or Cb signal. Incorporates LPF to reject carrier.		DC ; 2.5 V Rainbow color bar ; 360 mV _{p-p}
48	R-Y / Cr output	Outputs R-Y (V) signal or Cr signal. Incorporates LPF to reject carrier. Pulling up the pin with 10 k Ω monitors CHROMA signal after ACC and TOF circuits (before demo input).		DC ; 2.5 V Rainbow color bar ; 360 mV _{p-p}

TOSHIBA

TC90A49P/F

TOSHIBA CMOS DIGITAL INTEGRATED CIRCUIT SILICON MONOLITHIC

TC90A49P, TC90A49F

3LINE DIGITAL Y / C SEPARATOR IC (MULTICOLOR TYPE)

The TC90A49P / F is a 3-line digital Y / C (luminance / chrominance) separation IC for PAL, NTSC, M-PAL and N-PAL format.

FEATURES

- TV format : NTSC (3.58), PAL, M-PAL, and N-PAL
- Dynamic comb filter
- Vertical edge enhancement circuit
- PLL 8 × multiplier circuit
- Internal 8-bit 4 fsc AD converter
- Internal 8-bit precision 8 fsc DA converter (2 ch)
- Sync tip clamp circuit
- Internal 4H-line memory
- I²C bus interface
- Package : DIP 20-pin and SOP 24-pin
- 5 V single power supply

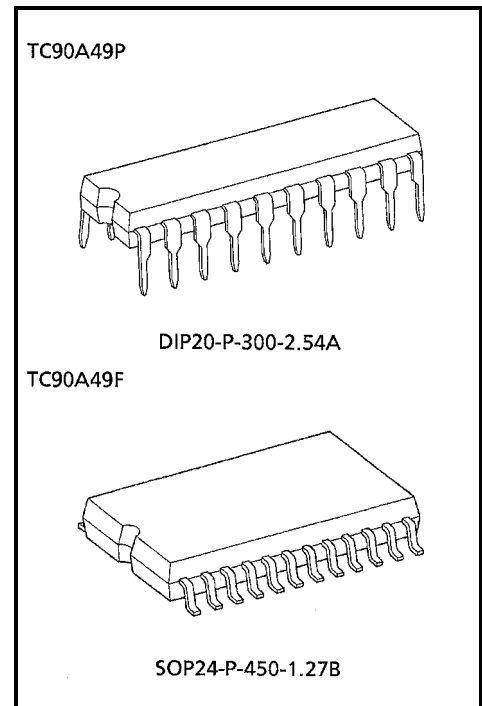

Weight

DIP20-P-300-2.54A : 1.11 g (Typ.)
 SOP24-P-450-1.27B : 0.44 g (Typ.)

BLOCK DIAGRAM

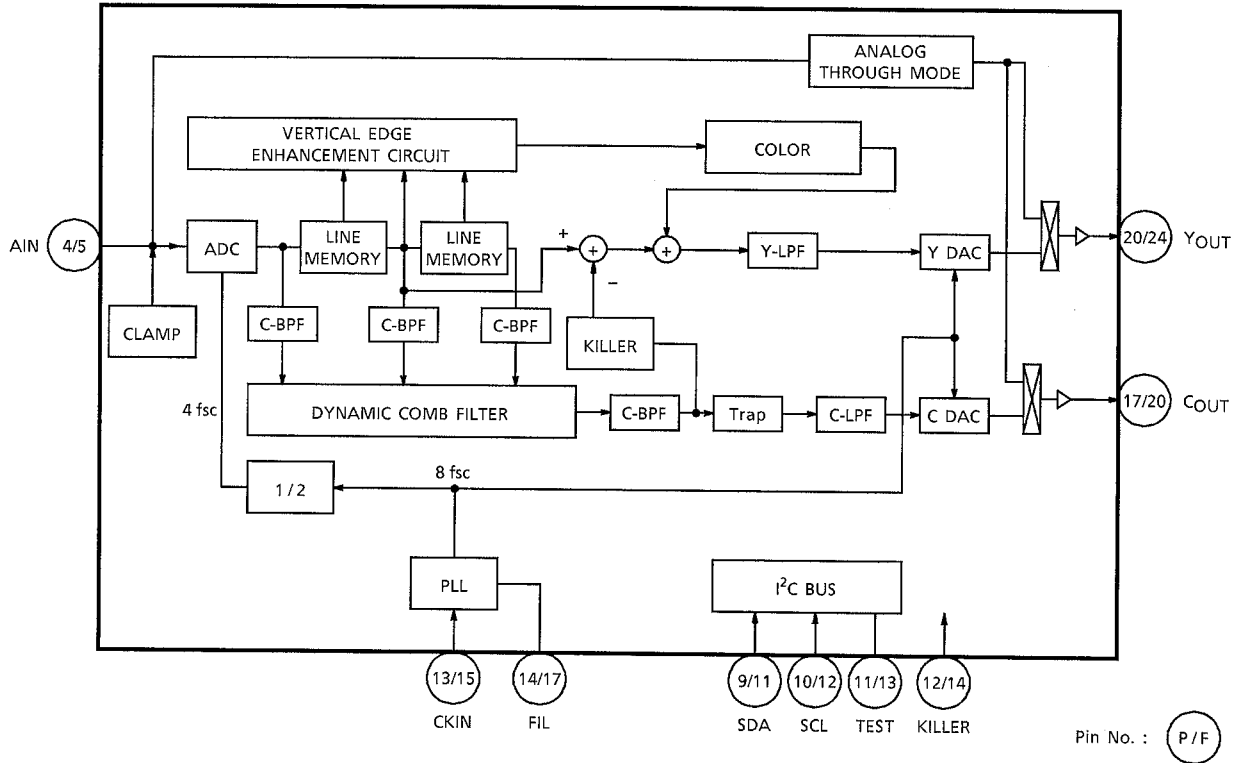

PIN ASSIGNMENT

TC90A49P

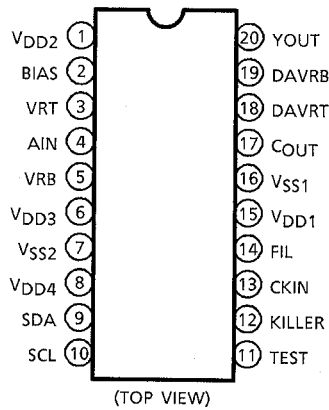

TC90A49F

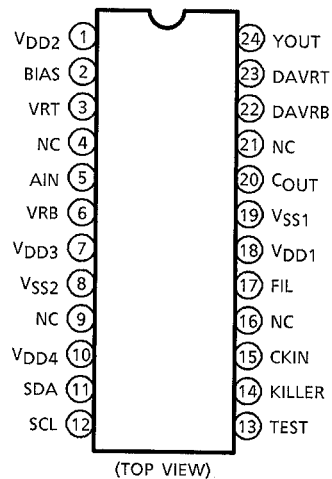

The NC which was writing in PIN ASSIGNMENT must use the open condition.

TOSHIBA

TC90A49P/F

PIN DESCRIPTION (no. before / indicates DIP package pin no.
no. after / indicates SOP package pin no.)

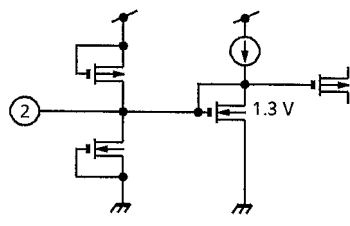
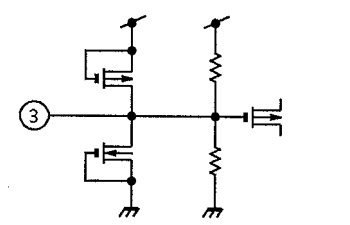
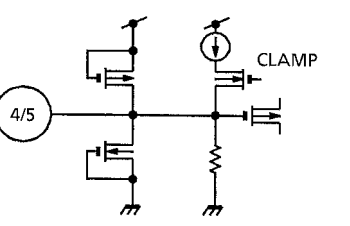
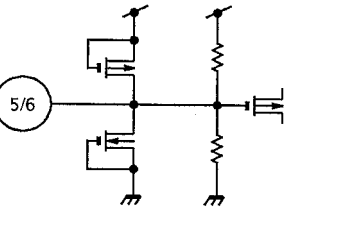
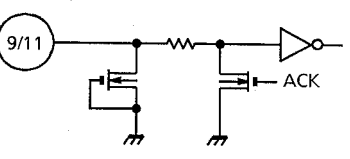
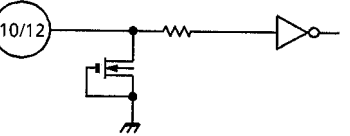
PIN No.	PIN NAME	FUNCTION	I / O	INTERFACE
1	V _{DD2}	ADC and DAC analog power supply.	-	-
2	BIAS	ADC bias voltage. Stabilize by attaching a 0.01μF capacitor.	-	
3	VRT	ADC input range D upper limit voltage. Stabilize by attaching a 0.01μF capacitor.	-	
4 / 5	AIN	ADC input. Inputs 1.0 V _{p-p} video signal. Sync tip clamp is performed.	I	
5 / 6	VRB	ADC input range D lower limit voltage. Stabilize by attaching a 0.01μF capacitor.	-	
6 / 7	V _{DD3}	ADC and DAC logic power supply.	-	-
7 / 8	V _{SS2}	Logic and internal DRAM GND (digital).	-	-
8 / 10	V _{DD4}	Internal DRAM power supply.	-	-
9 / 11	SDA	I ² C BUS SDA	I / O	
10 / 12	SCL	I ² C BUS SCL	I	

TOSHIBA

TC90A49P/F

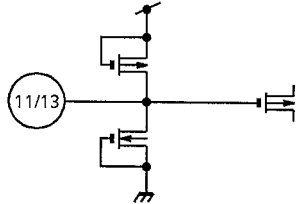
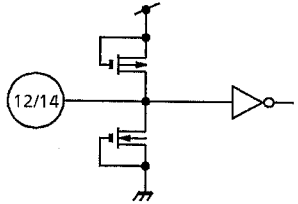
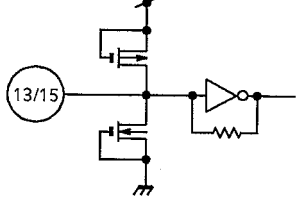
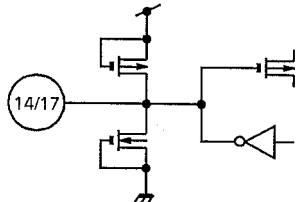
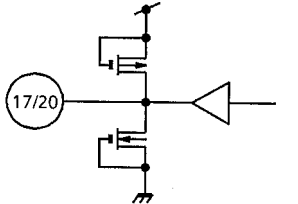
PIN No.	PIN NAME	FUNCTION	I / O	INTERFACE
11 / 13	TEST	Shipment test mode switch or I ² C bus setting reset pin. When High, test mode, setting all I ² C bus settings to 0. Hold High for at least 100μs. Send I ² C bus settings when this pin is Low.	I	
12 / 14	KILLER	Y signal comb function ON / OFF switch. When High, comb OFF. When Low, comb ON. When [data 3 : bit 0] is 1, used as vertical edge enhancement circuit ON / OFF switch.	I	
13 / 15	CKIN	Clock input pin. Pin 13 put a sine wave which is locked to the frequency of the burst signal in the input video signal. Amplitude is 300 mV p-p to 2 Vp-p. Input as high an amplitude as possible without affecting peripheral circuits.	I	
14 / 17	FIL	Connect the APC filter in the 8 fsc PLL circuit.	-	
15 / 18	VDD1	PLL power supply.	-	-
16 / 19	VSS1	ADC, DAC, and PLL GND (analog).	-	-
17 / 20	COUT	Outputs chrominance signal. External simple LPF for clock elimination recommended.	O	

TOSHIBA**TC90A49P/F**

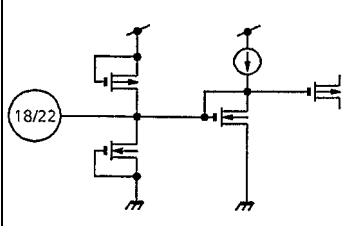
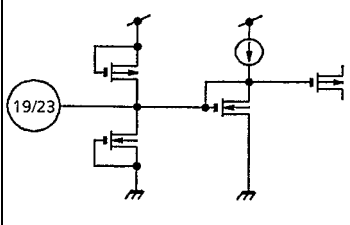
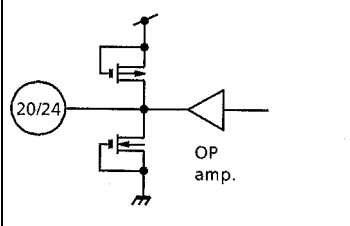
PIN No.	PIN NAME	FUNCTION	I / O	INTERFACE
18 / 22	DAVRT	DAC output range D upper limit voltage. Stabilize by attaching a 0.01 μ F capacitor.	-	
19 / 23	DAVRB	DAC output range D lower limit voltage. Stabilize by attaching a 0.01 μ F capacitor.	-	
20 / 24	YOUT	Outputs luminance signal. External simple LPF for clock elimination recommended.	O	

BH7862FS

Multimedia ICs

High-performance 6-channel video driver IC for progressive DVD

BH7862FS

BH7862FS is a 6-channel video driver IC developed for progressive DVD player/recorder. Special filters adjusted to each band of various video signals are incorporated into a single chip. Extended definition, size reduction, and high cost performance can be achieved in DVD players.

●Application

DVD players, DVD recorders

●Features

- 1) Each high-performance filter, 6dB amplifier, and 75Ω driver for DVD are incorporated into a single chip.
- 2) Driver 6ch (Y, C, MIX, and PY, Pb, Pr for progressive)
- 3) Group delay difference between chroma signal and luminance signal is a small number of nsec.
- 4) Drive 2 lines of each signal
- 5) Operating by 5V single power supply
- 6) Built-in mute circuit

●Absolute maximum ratings (Ta = 25°C)

Parameter	Symbol	Limits	Unit
Impressed voltage	V _{cc max}	6.0	V
Power dissipation	P _d	0.95*	W
Operating temperature range	T _{opr}	-10~+70	°C
Storage temperature range	T _{stg}	-55~+150	°C

* Reduced by -7.6mW for each increase in Ta of 1°C over 25°C.
PCB (70mm×70mm, t=1.6mm) glass epoxy mounting.

●Recommended operating conditions (Ta = 25°C)

Parameter	Symbol	Min.	Typ.	Max.	Unit
Power supply voltage	V _{cc}	4.5	-	5.5	V

©Radiation resistance is not included in the design.

BH7862FS

Multimedia ICs

●Block diagram

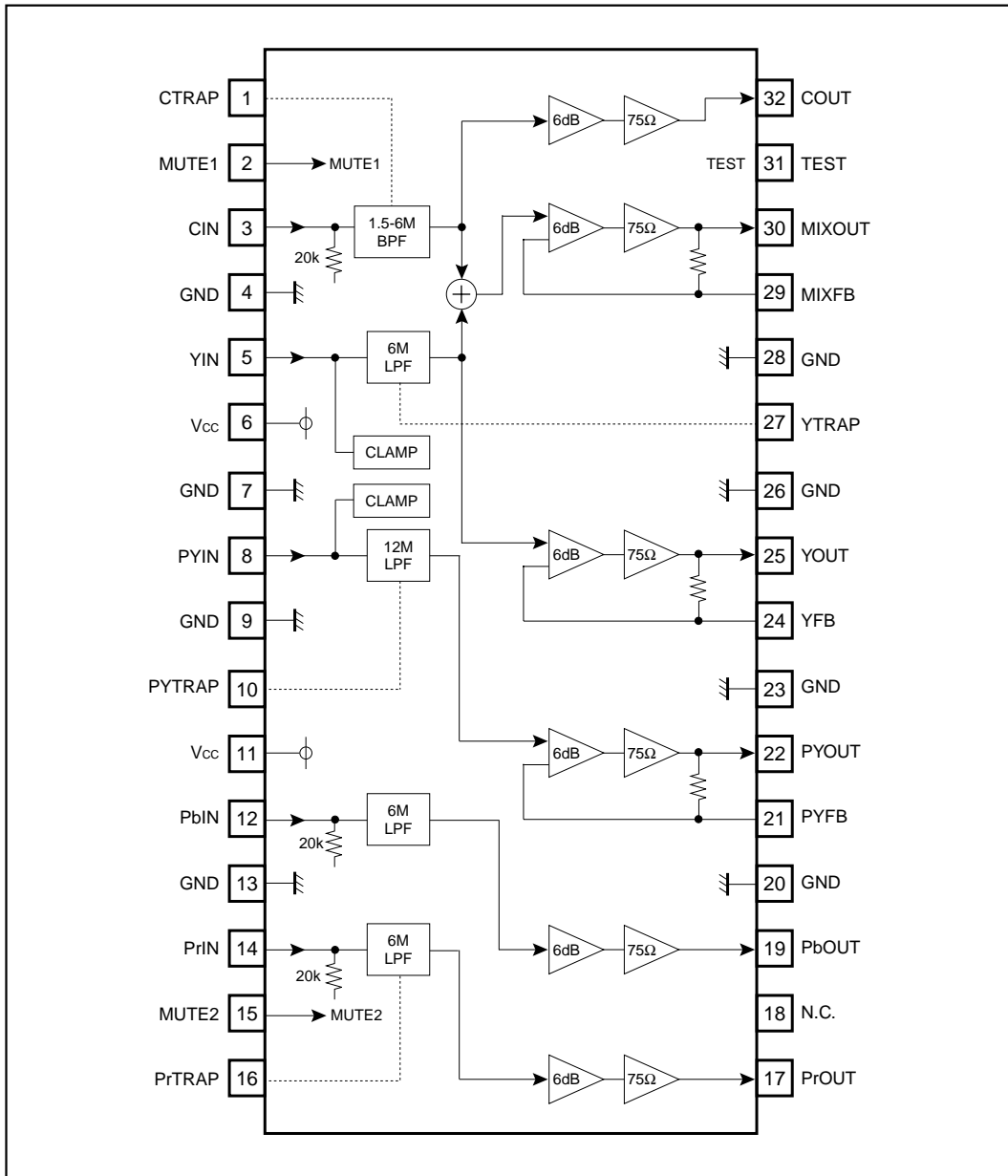

BH7862FS

Multimedia ICs

●Pin descriptions and Input / output circuits

Pin No.	Pin name	Input/output equivalent circuit	Pin description
3 12 14	CIN PbIN PrIN		Signal input terminal. Input terminal for chroma signal and color-difference signal. Bias type input. The input impedance is 20kΩ.
5 8	YIN PYIN		Signal input terminal. Input terminal for luminance signal. Di clamp input.
32	COUT		Signal output terminal. Output terminal for chroma signal.
29 30	MIXFB MIXOUT		Signal output terminal. Output terminal for Y/C MIX signal.
24 25	YFB YOUT		Signal output terminal. Output terminal for luminance signal (interlaced type).

BH7862FS

Multimedia ICs

Pin No.	Pin name	Input/output equivalent circuit	Pin description
21 22	PYFB PYOUT		Signal output terminal. Output terminal for luminance signal (progressive type).
17 19	PrOUT PbOUT		Signal output terminal. Output terminal for color-difference signal.
1 27 10 16	CTPAP YTRAP PYTRAP PrTRAP		Terminal for LC resonance.
6 11	Vcc		Power supply voltage. Vcc is separated into 6 pin and 11 pin. That is to say, C, MIX and Y are partitioned by 6 pin and PY, Pb and Pr by 11 pin. They are not connected internally. Connect them externally when using.
4 7 9 13 20 23 26 28	GND		Grounding terminal.
2	MUTE1		Mute control terminal. C, MIX and Y are muted simultaneously by setting MUTE to "L".

BH7862FS

Multimedia ICs

Pin No.	Pin name	Input/output equivalent circuit	Pin description
12	MUTE2	<p>The diagram shows an input terminal connected to a pull-up resistor. A diode is connected from the terminal to ground. The other end of the pull-up resistor is connected to the base of a transistor. The emitter of the transistor is grounded, and the collector is connected to a signal line.</p>	<p>Mute control terminal.</p> <p>PY, Pb and PR are muted simultaneously by setting MUTE to "L".</p>
31	TEST		<p>Test terminal.</p> <p>Usually, short-circuit this terminal to GND when using it.</p>
18	N.C.		–

Ordering number : ※ EN5039

CMOS IC

SANYO	No. ※ 5039	LC74763, 74763M
		On-Screen Display LSI

Preliminary

Overview

The LC74763 and LC74763M are on-screen display CMOS LSIs that superimpose text and low-level graphics onto a TV screen (video signal) under the control of a microcontroller. The display characters have a 12 by 18 dots structure, and 128 characters are provided.

Features

- Display structure: 12 lines by 24 characters (up to 288 characters)
- Maximum character display: Up to 288 characters
- Character configuration: 12 (W) by 18 (H) dots structure
- Number of characters: 128 characters (128 plus space 2 fonts)
- Character sizes: Three sizes (normal, double, and triple sizes)
- Display starting positions: 64 horizontal and 64 vertical locations
- Reverse video function: Characters can be inverted on a per character basis.
- Flashing types: Two types with periods of 0.5 and 1.0 second on a per character basis (duty fixed at 50%)
- Background color: One of eight colors (when internal synchronization used)
- External control input: Serial data input in 8-bit units
- Built-in horizontal/vertical sync separation circuit, AFC circuit, and synchronization detector
- Video output: Composite video signal output in NTSC, PAL, PAL-M, PAL-N, PAL60, NTSC4.43, or SECAM format

Package Dimensions

unit: mm

3196-DIP30SD

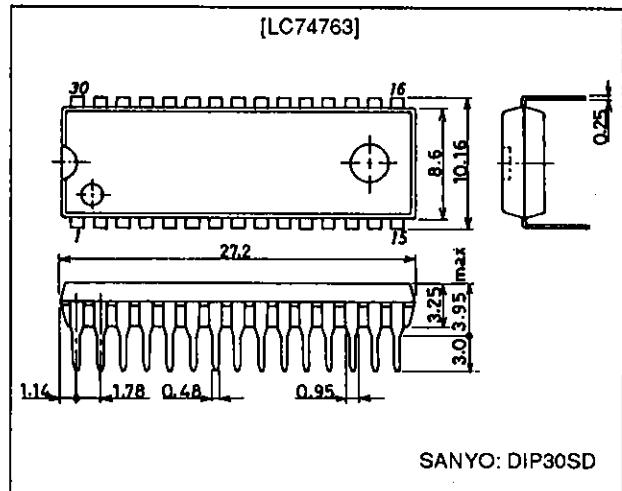

3216A-MFP30S

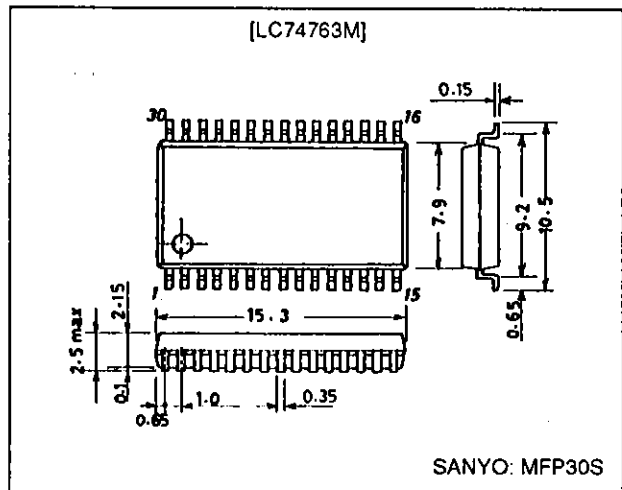

O.S.D IC (74763M)

Pin Functions (IC51)

Pin No.	Symbol	Function	Description
1	V _{SS}	Ground	Ground connection
2	Xtal _{IN1}	Crystal oscillator connection	Connection for the crystal and capacitor used to form the crystal oscillator that generates the internal synchronization signal. The oscillator can be selected with a command switch.
3	Xtal _{OUT1}		
4	HSYNC _{OUT}	Horizontal synchronization output	Outputs the horizontal synchronization signal (AFC). The output polarity can be selected (metal option). Also functions as general output port (command switch).
5	Xtal _{IN2}	Crystal oscillator connection	Connection for the crystal and capacitor used to form the crystal oscillator that generates the internal synchronization signal.
6	Xtal _{OUT2}		
7	VSYNC _{OUT}	Vertical synchronization output	Outputs the vertical synchronization signal. The output polarity can be selected (metal option). Also functions as general output port (command switch).
8	\overline{CS}	Enable input	Enables/disables serial data input. Serial data is enabled when this pin is low (hysteresis input). Pull-up resistor built in (metal option).
9	SIN	Data input	Serial data input (hysteresis input). Pull-up resistor built in (metal option).
10	SCLK	Clock input	Clock input for serial data input (hysteresis input). Pull-up resistor built in (metal option).
11	SECAM	SECAM mode switch input/output (command switch)	During input, switches between SECAM and other modes. During output, functions as general output port or internal V output (command switch). Low = other modes, high = SECAM mode
12	$\overline{525/625}$	525/625 switch input/output (command switch)	During input, switches between 525 scan lines and 625 scan lines. During output, functions as general output port or character data output (command switch). Low = 525 lines, high = 625 lines
13	$\overline{NTSC/PAL}$	NTSC/PAL switch input/output (command switch)	Switches the color mode between NTSC and PAL. During output, functions as general output port or frame data output (command switch). Low = NTSC, high = PAL
14	$\overline{3.58/4.43}$	3.58/4.43 switch input/output (command switch)	Switch FSC between 3.58 MHz and 4.43 MHz. During output, functions as general output port or halftone output (command switch). Low = 3.58, high = 4.43
15	\overline{RST}	Reset input	System reset input pin, low is active (hysteresis input). Pull-up resistor built in (metal option).
16	CV _{OUT}	Video signal output	Composite video output
17	V _{DD2}	Power supply connection	Power supply connection for composite video signal level generation
18	CV _{IN}	Video signal input	Composite video input
19	CV _{CR}	Video signal input	SECAM chroma signal input
20	SYNC _{IN}	Sync separator circuit input	Built-in sync separator circuit video signal input
21	SEP _C	Sync separator circuit	Built-in sync separator circuit
22	V _{SS}	Ground	Ground connection
23	PD _{OUT}	Control voltage output	AFC control voltage output
24	AMP _{IN}	AFC filter connection	Filter connection
25	AMP _{OUT}		
26	FC	Control voltage input	AFC control voltage input
27	VCO _{IN}	LC oscillator connection	VCO LC oscillator circuit coil and capacitor connection
28	VCO _{OUT}		
29	SYNC _{DET}	External synchronization signal detection output	Outputs the exclusive NOR of the horizontal synchronization signal (AFC) and CSYNC (sync separator). The output polarity can be selected (metal option). Also functions as general output port (command switch).
30	V _{DD1}	Power supply connection	Power supply connection (+5 V: digital system power supply)

LC74763, 74763M

Pin Assignment

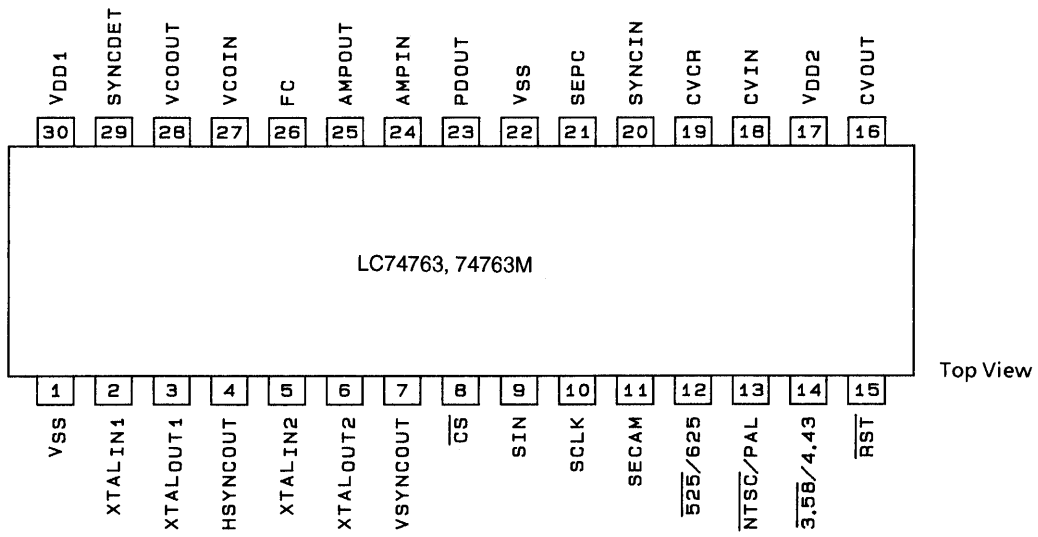

Top View

A03518

Top view

Serial Data Input Timing

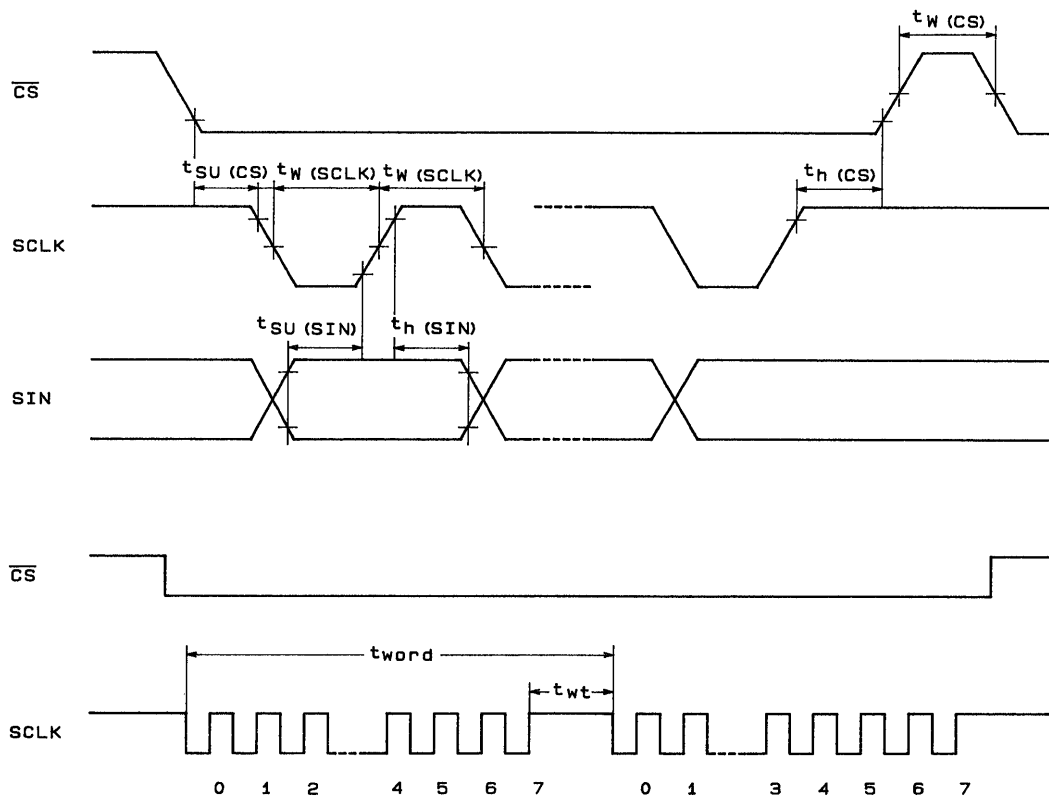

A03519

LC74763M BLOCK DIAGRAM

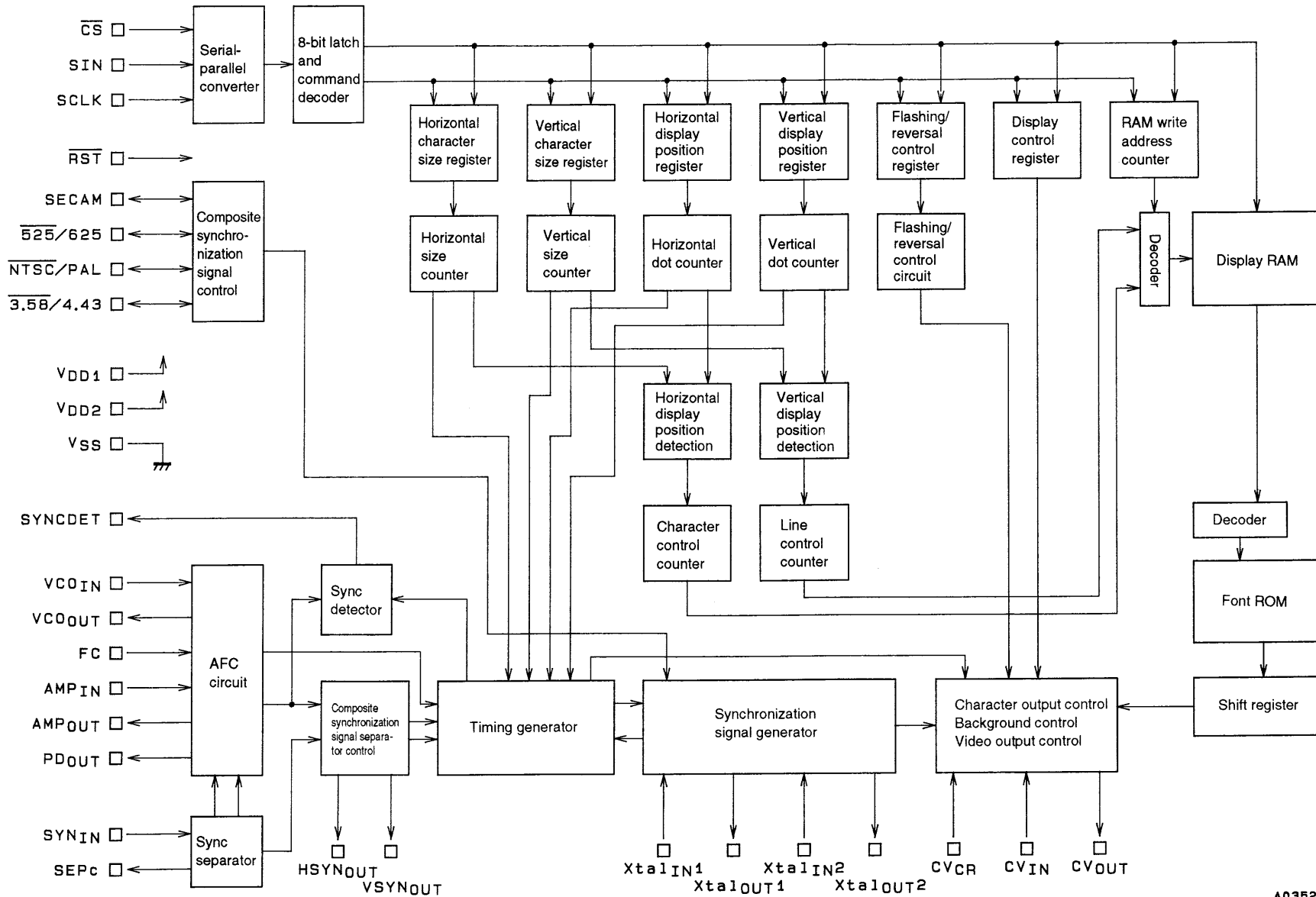

A03520

U-COM IC PIN ASSIGNMENT & DESCRIPTIONS

■ PIN ASSIGNMENT (IC72)

(TOP VIEW)

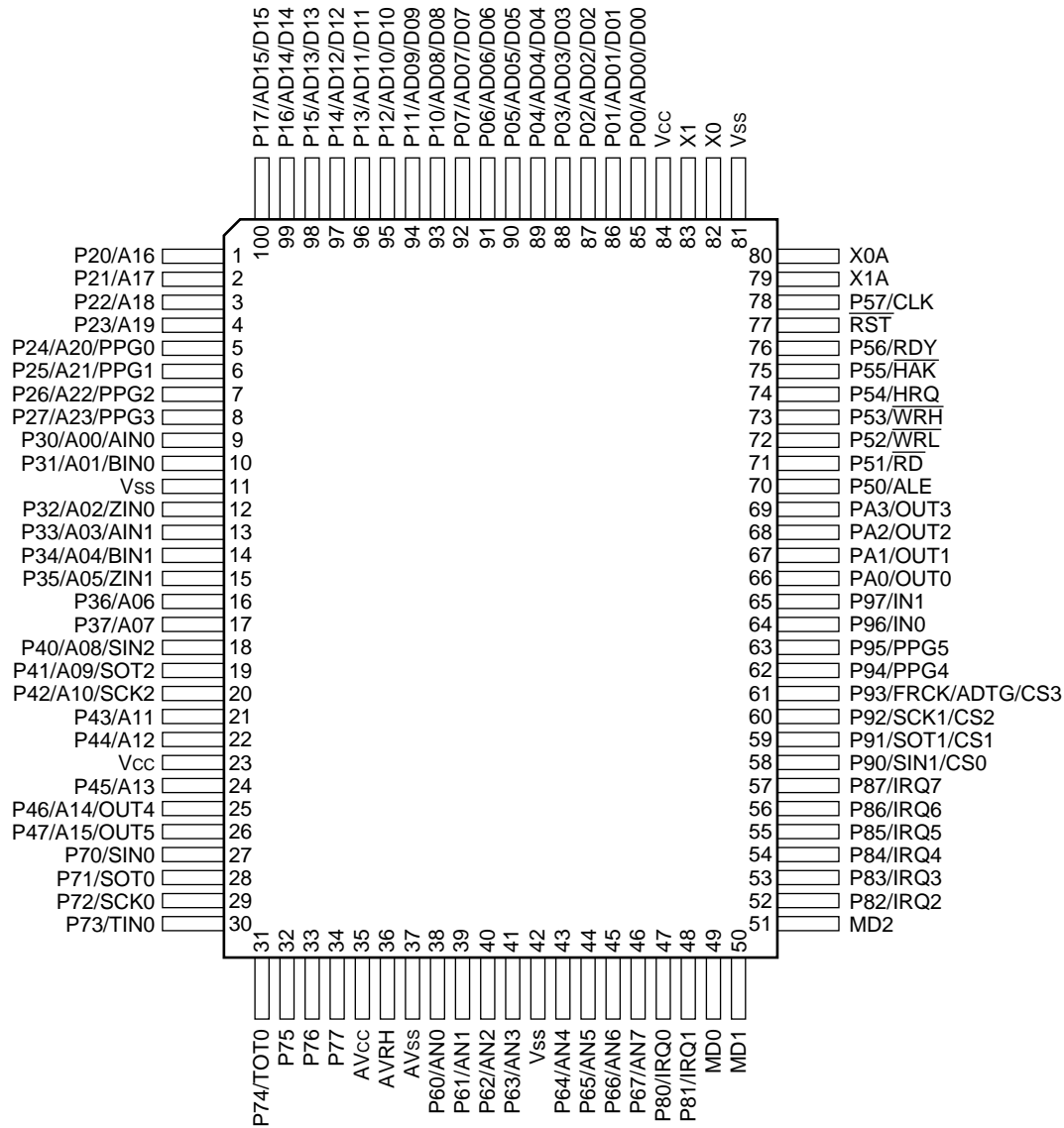

(FPT-100P-M06)

MB90482

■ PIN DESCRIPTIONS (IC72)

Pin No.		Pin name	Circuit type	Function
LQFP*1	QFP*2			
80	82	X0	A	Oscillator pin
81	83	X1	A	Oscillator pin
78	80	X0A	A	32 kHz oscillator pin
77	79	X1A	A	32 kHz oscillator pin
75	77	$\overline{\text{RST}}$	B	Reset input pin
83 to 90	85 to 92	P00 to P07	C (CMOS)	This is a general purpose I/O port. A setting in the pull-up resistance setting register (RDR0) can be used to apply pull-up resistance (RD00-RD07 = "1") . (Disabled when pin is set for output.)
		AD00 to AD07		In multiplex mode, these pins function as the external address/ data bus low I/O pins.
		D00 to D07		In non-multiplex mode, these pins function as the external data bus low output pins.
91 to 98	93 to 100	P10 to P17	C (CMOS)	This is a general purpose I/O port. A setting in the pull-up resistance setting register (RDR1) can be used to apply pull-up resistance (RD10-RD17 = "1") . (Disabled when pin is set for output.)
		AD08 to AD15		In multiplex mode, these pins function as the external address/ data bus high I/O pins.
		D08 to D15		In non-multiplex mode, these pins function as the external data bus high output pins.
99, 100, 1,2	1 to 4	P20 to P23	E (CMOS/H)	This is a general purpose I/O port. When the bits of external address output control register (HACR) are set to "1" in external bus mode, these pins function as general purpose I/O ports.
		A16 to A19		When the bits of external address output control register (HACR) are set to "0" in multiplex mode, these pins function as address high output pins (A16-A19).
		A16 to A19		When the bits of external address output control register (HACR) are set to "0" in non-multiplex mode, these pins function as address high output pins (A16-A19).
3 to 6	5 to 8	P24 to P27	E (CMOS/H)	This is a general purpose I/O port. When the bits of external address output control register (HACR) are set to "1" in external bus mode, these pins function as general purpose I/O ports.
		A20 to A23		When the bits of external address output control register (HACR) are set to "0" in multiplex mode, these pins function as address high output pins (A20-A23).
		A20 to A23		When the bits of external address output control register (HACR) are set to "0" in non-multiplex mode, these pins function as address high output pins (A20-A23).
		PPG0 to PPG3		PPG timer output pins.

(Continued)

MB90482

Pin No.		Pin name	Circuit type	Function
LQFP*1	QFP*2			
7	9	P30	E (CMOS/H)	This is a general purpose I/O port.
		A00		In non-multiplex mode, this pin functions as an external address pin.
		AIN0		8/16-bit up/down timer input pin (channel 0) .
8	10	P31	E (CMOS/H)	This is a general purpose I/O port.
		A01		In non-multiplex mode, this pin functions as an external address pin.
		BIN0		8/16-bit up/down counter input pin (channel0) .
10	12	P32	E (CMOS/H)	This is a general purpose I/O port.
		A02		In non-multiplex mode, this pin functions as an external address pin.
		ZIN0		8/16-bit up/down counter input pin (channel 0)
11	13	P33	E (CMOS/H)	This is a general purpose I/O port.
		A03		In non-multiplex mode, this pin functions as an external address pin.
		AIN1		8/16-bit up/down counter input pin (channel 1) .
12	14	P34	E (CMOS/H)	This is a general purpose I/O port.
		A04		In non-multiplex mode, this pin functions as an external address pin.
		BIN1		8/16-bit up/down counter input pin (channel 1) .
13	15	P35	E (CMOS/H)	This is a general purpose I/O port.
		A05		In non-multiplex mode, this pin functions as an external address pin.
		ZIN1		8/16-bit up/down counter input pin (channel 1)
14 15	16 17	P36, P37 A06, A07	D*3 (CMOS)	This is a general purpose I/O port. In non-multiplex mode, this pin functions as an external address pin.
16	18	P40	G (CMOS/H)	This is a general purpose I/O port.
		A08		In non-multiplex mode, this pin functions as an external address pin.
		SIN2		Simple serial I/O input pin.
17	19	P41	F (CMOS)	This is a general purpose I/O port.
		A09		In non-multiplex mode, this pin functions as an external address pin.
		SOT2		Simple serial I/O output pin.
18	20	P42	G (CMOS/H)	This is a general purpose I/O port.
		A10		In non-multiplex mode, this pin functions as an external address pin.
		SCK2		Simple serial I/O clock input/output pin.

(Continued)

MB90482

Pin No.		Pin name	Circuit type	Function
LQFP*1	QFP*2			
19 20	21 22	P43, P44	F (CMOS)	This is a general purpose I/O port.
		A11, A12		In non-multiplex mode, this pin functions as an external address pin.
22	24	P45	F*4 (CMOS)	This is a general purpose I/O port.
		A13		In non-multiplex mode, this pin functions as an external address pin.
23 24	25 26	P46, P47	F (CMOS)	This is a general purpose I/O port.
		A14, A15		In non-multiplex mode, this pin functions as an external address pin.
		OUT4/OUT5		Output compare event output pins.
68	70	P50	D (CMOS)	This is a general purpose I/O port. In external bus mode, this pin functions as the ALE pin.
		ALE		In external bus mode, this pin functions as the address load enable (ALE) signal pin.
69	71	P51	D (CMOS)	This is a general purpose I/O port. In external bus mode, this pin functions as the \overline{RD} pin.
		\overline{RD}		In external bus mode, this pin functions as the read strobe output (\overline{RD}) signal pin.
70	72	P52	D (CMOS)	This is a general purpose I/O port. In external bus mode, when the WRE pin in the EPCR register is set to "1", this pin functions as the \overline{WRL} pin.
		\overline{WRL}		In external bus mode, this pin functions as the lower data write strobe output (\overline{WRL}) pin. When the WRE bit in the EPCR register is set to "0", this pin functions as a general purpose I/O port.
71	73	P53	D (CMOS)	This is a general purpose I/O port. In external bus mode with 16-bit bus width, when the WRE bit in the EPCR register is set to "1", this pin functions as the \overline{WRH} pin.
		\overline{WRH}		In external bus mode with 16-bit bus width, this pin functions as the upper data write strobe output (\overline{WRH}) pin. When the WRE bit in the EPCR register is set to "0", this pin functions as a general purpose I/O port.
72	74	P54	D (CMOS)	This is a general purpose I/O port. In external bus mode, when the HDE bit in the EPCR register is set to "1", this pin functions as the HRQ pin.
		HRQ		In external bus mode, this pin functions as the hold request input (HRQ) pin. When the HDE bit in the EPCR register is set to "0", this pin functions as a general purpose I/O port.
73	75	P55	D (CMOS)	This is a general purpose I/O port. In external bus mode, when the HDE bit in the EPCR register is set to "1", this pin functions as the \overline{HAK} pin.
		\overline{HAK}		In external bus mode, this pin functions as the hold acknowledge (\overline{HAK}) pin. When the HDE bit in the EPCR register is set to "0", this pin functions as a general purpose I/O port.

(Continued)

Pin No.		Pin name	Circuit type	Function
LQFP*1	QFP*2			
74	76	P56	D (CMOS)	This is a general purpose I/O port. In external bus mode, when the RYE bit in the EPCR register is set to "1", this pin functions as the RDY pin.
		RDY		In external bus mode, this pin functions as the external ready (RDY) input pin. When the RYE bit in the EPCR register is set to "0", this pin functions as a general purpose I/O port.
76	78	P57	D (CMOS)	This is a general purpose I/O port. In external bus mode, when the CKE bit in the EPCR register is set to "1", this pin functions as the CLK pin.
		CLK		In external bus mode, this pin functions as the machine cycle clock (CLK) output pin. When the CKE bit in the EPCR register is set to "0", this pin functions as a general purpose I/O port.
36 to 39	38 to 41	P60 to P63	H (CMOS)	These are general purpose I/O ports.
		AN0 to AN3		These are the analog input pins.
41 to 44	43 to 46	P64 to P67	H (CMOS)	These are general purpose I/O ports.
		AN4 to AN7		These are the analog input pins.
25	27	P70	G (CMOS/H)	This is a general purpose I/O port.
		SIN0		This is the UART data input pin.
26	28	P71	F (CMOS)	This is a general purpose I/O port.
		SOT0		This is the UART data output pin.
27	29	P72	G (CMOS/H)	This is a general purpose I/O port.
		SCK0		This is the UART clock I/O pin.
28	30	P73	G (CMOS/H)	This is a general purpose I/O port.
		TIN0		This is the 16-bit reload timer event input pin.
29	31	P74	F (CMOS)	This is a general purpose I/O port.
		TOT0		This is the 16-bit reload timer output pin.
30	32	P75	F*4 (CMOS)	This is a general purpose I/O port.
31	33	P76	F*5 (CMOS)	This is a general purpose I/O port.
32	34	P77	F*5 (CMOS)	This is a general purpose I/O port.
45, 46	47, 48	P80, P81	E (CMOS/H)	These are general purpose I/O ports.
		IRQ0, IRQ1		External interrupt input pins.
50 to 55	52 to 57	P82 to P87	E (CMOS/H)	These are general purpose I/O ports.
		IRQ2 to IRQ7		External interrupt input pins.

(Continued)

MB90482

(Continued)

Pin No.		Pin name	Circuit type	Function
LQFP*1	QFP*2			
56	58	P90	E (CMOS/H)	This is a general purpose I/O port.
		SIN1		Simple serial I/O data input pin.
		CS0		Chip select 0.
57	59	P91	D (CMOS)	This is a general purpose I/O port.
		SOT1		Simple serial I/O data output pin.
		CS1		Chip select 1.
58	60	P92	E (CMOS/H)	This is a general purpose I/O port.
		SCK1		Simple serial I/O data input/output pin.
		CS2		Chip select 2.
59	61	P93	E (CMOS/H)	This is a general purpose I/O port.
		FRCK		When the free run timer is in use, this pin functions as the external clock input pin.
		ADTG		When the A/D converter is in use, this pin functions as the external trigger input pin.
		CS3		Chip select 3.
60	62	P94	D (CMOS)	This is a general purpose I/O port.
		PPG4		PPG timer output pin.
61	63	P95	D (CMOS)	This is a general purpose I/O port.
		PPG5		PPG timer output pin.
62	64	P96	E (CMOS/H)	This is a general purpose I/O port.
		IN0		Input capture channel 0 trigger input pin.
63	65	P97	E (CMOS/H)	This is a general purpose I/O port.
		IN1		Input capture channel 1 trigger input pin.
64 to 67	66 to 69	PA0 to PA3	D (CMOS)	These are general purpose I/O ports.
		OUT0 to OUT3		Output compare event output pins.
33	35	AV _{cc}	—	A/D converter power supply pin.
34	36	AVRH	—	A/D converter external reference voltage supply pin.
35	37	AV _{ss}	—	A/D converter power supply pin.
47 to 49	49 to 51	MD0 to MD2	J (CMOS/H)	Operating mode selection input pins.
21, 82	23, 84	V _{cc}	—	3.3 V ± 0.3 V power supply pins (V _{cc3}) .
9, 40, 79	11, 42, 81	V _{ss}	—	Power supply input pins (GND) .

*1 : LQFP : FPT-100P-M05

*2 : QFP : FPT-100P-M06

*3 : The circuit type of MB90V480 is E (CMOS/H).

*4 : The circuit type of MB90V480 is G (CMOS/H).

*5 : The circuit type of MB90V480 is I (NMOS/H)

NJM2068M (OP - AMP)



NJM2068

LOW-NOISE DUAL OPERATIONAL AMPLIFIER

■ **GENERAL DESCRIPTION**

The NJM2068 is a high performance, low noise dual operational amplifier. This amplifier features popular pin-out, superior noise performance, and superior total harmonic distortion. This amplifier also features guaranteed noise performance with substantially higher gain-bandwidth product and slew rate which far exceeds that of the 4558 type amplifier. The specially designed low noise input transistors allow the NJM2068 to be used in very low noise signal processing applications such as audio preamplifiers and servo error amplifier.

■ **PACKAGE OUTLINE**

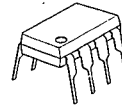

NJM2068D



NJM2068M



NJM2068V

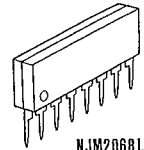

NJM2068L

■ **FEATURES**

- Operating Voltage (±4V ~ ±18V)
- Low Total Harmonic Distortion (0.001% typ.)
- Low Noise Voltage (FLAT+JISA, 0.56 μV typ.)
- High Slew Rate (6V/μs typ.)
- Unity Gain Bandwidth (27MHz @f=10kHz)
- Package Outline DIP8, DMP8, SIP8, SSOP8
- Bipolar Technology

■ **PIN CONFIGURATION**

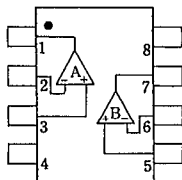

NJM2068D
NJM2068M
NJM2068V

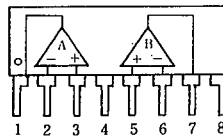

NJM2068L

PIN FUNCTION

1. A OUTPUT
2. A-INPUT
3. A+INPUT
4. V-
5. B+INPUT
6. B-INPUT
7. B OUTPUT
8. V+

■ **EQUIVALENT CIRCUIT (1/2 Shown)**

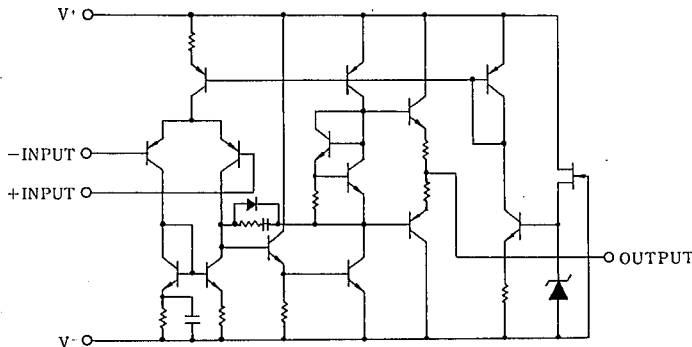

5-INPUT 3-OUTPUT VIDEO SW

■GENERAL DESCRIPTION

The NJM2296 is a 5-input 3-output video switch.

Its switches select one from five signals received from VTR, TV, TV GAME and others.

This IC is designed for audio items, such as AV amplifier and receivers, and others

■PACKAGE OUTLINE

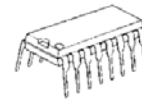

NJM2296D

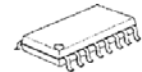

NJM2296M

■FEATURES

- 5-input 3-output
- Operating Voltage ± 4.0 to $\pm 6.5V$
- Operating Current $\pm 31mA$ typ. at $V_{cc}=\pm 5V$
- Crosstalk $-65dB$ typ.
- Internal 6dB Amplifier
- Internal 75Ω Driver
- Bipolar Technology
- Package Outline DIP16,DMP16

■BLOCK DIAGRAM

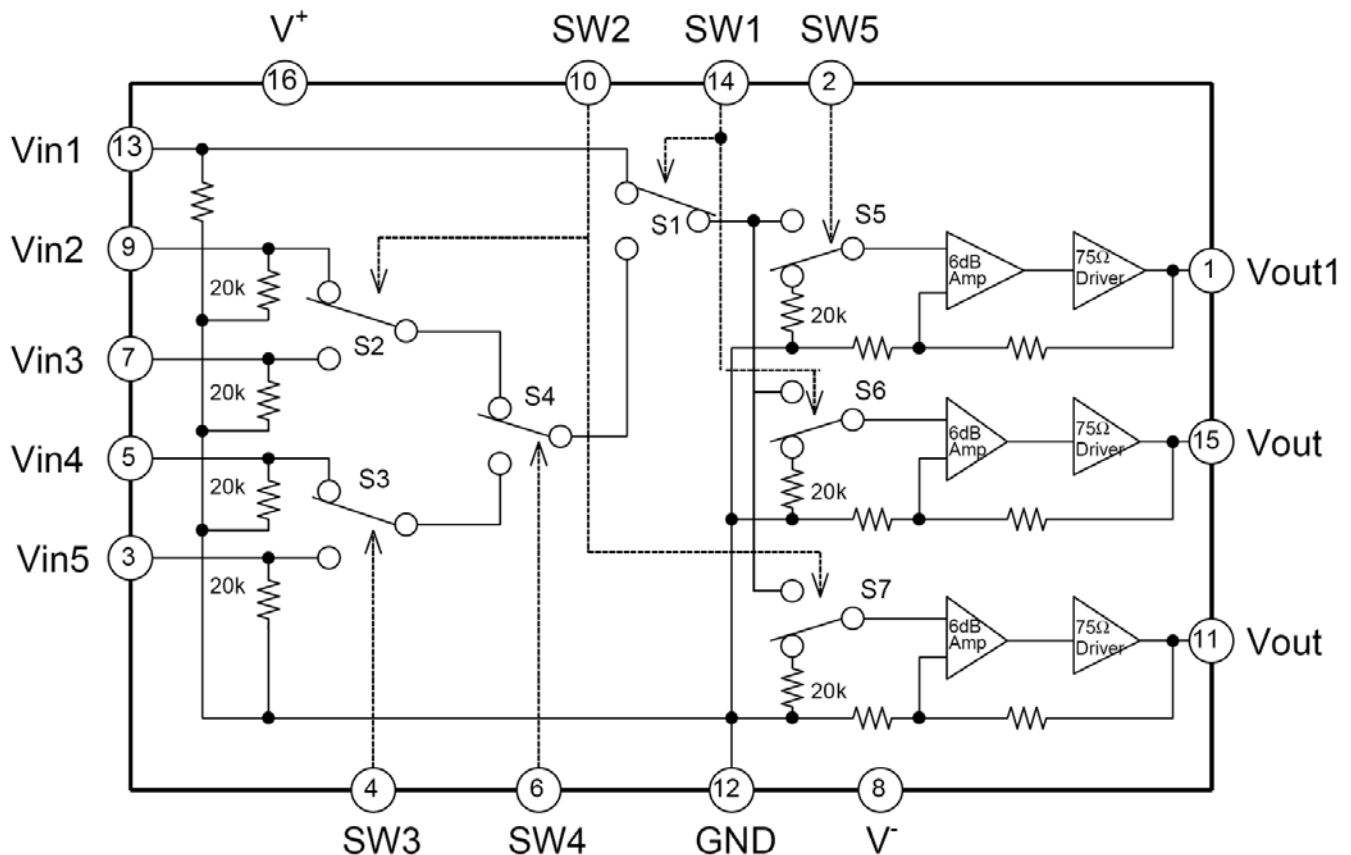



NJM2581

DUAL SUPPLY WIDE BAND 3ch VIDEO AMPLIFIER

■ GENERAL DESCRIPTION

The **NJM2581** is a dual supply voltage wide band 3ch video amplifier. It is suitable for Y, Pb, and Pr signal because frequency range is 50MHz.

The **NJM2581** is suitable for Set Top Box, AV amplifier, and other high quality AV systems.

■ PACKAGE OUTLINE

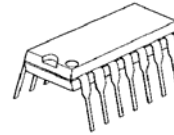

NJM2581D

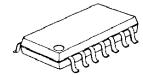

NJM2581M

■ FEATURES

- Operating Voltage ± 4.5 to ± 5.5 V
- Wide frequency range 50MHz at 0dB typ.
- Internal 6dB Amplifier
- Internal 75Ω Driver Circuit (2-system drive)
- Power Save Circuit
- Bipolar Technology
- Package Outline DIP14, DMP14

■ BLOCK DIAGRAM

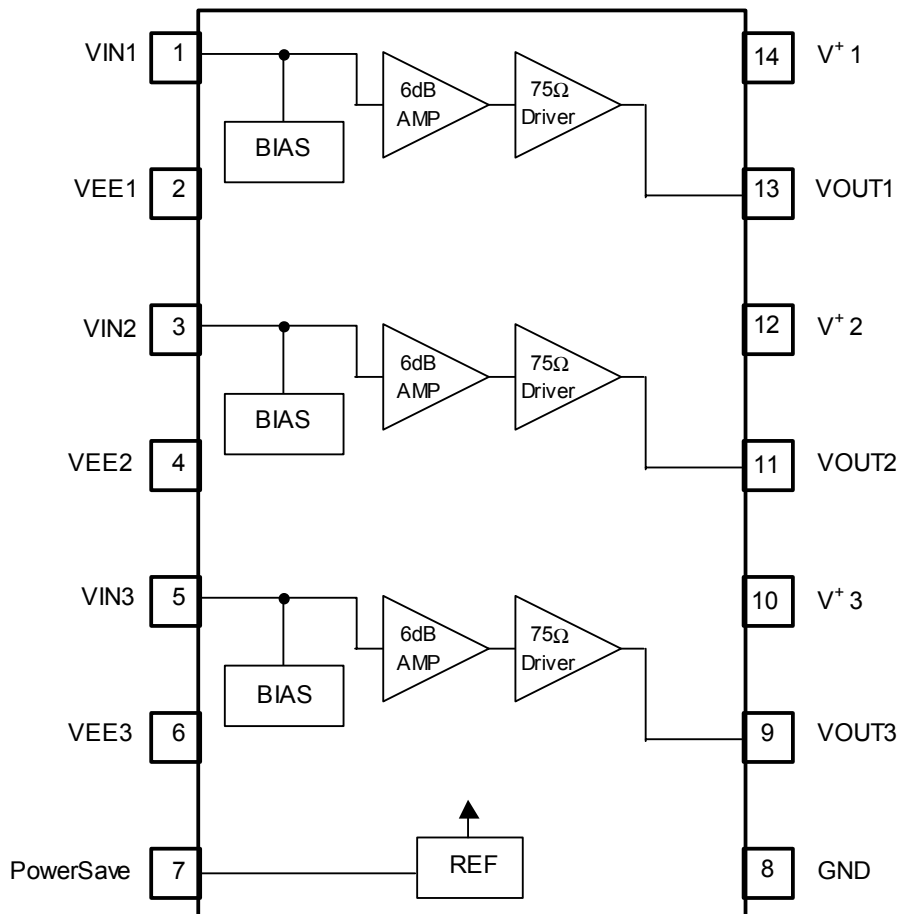

NJM2581

■ EQUIVALENT CIRCUIT

PIN No.	PIN NAME	FUNCTION	INSIDE EQUIVALENT CIRCUIT
1 3 5	VIN1 VIN2 VIN3	Input	
13 11 9	VOUT1 VOUT2 VOUT3	Output	
7	PowerSave	Power Save	
14 12 10	V ⁺ 1 V ⁺ 2 V ⁺ 3	V+	_____
2 4 6	VEE1 VEE2 VEE3	V-	_____
8	GND	GND	_____



IC86

NJM4556A

DUAL HIGH CURRENT OPERATIONAL AMPLIFIER

■ GENERAL DESCRIPTION

The NJM4556A integrated circuit is a high-gain, high output current dual operational amplifier capable of driving $\pm 70\text{mA}$ into $150\ \Omega$ loads ($\pm 10.5\text{V}$ output voltage), and operating low supply voltage ($V^+/V^- = \pm 2\text{V} \sim$).

The NJM4556A combines many of the fetures of the popular NJM4558 as well as having the capability of driving $150\ \Omega$ loads. In addition, the wide band-width, low noise, high slew rate and low distortion of the NJM4556A make it ideal for many audio, telecommuncations and instrumentation applications.

■ FEATURES

- Operating Voltage ($\pm 2\text{V} \sim \pm 18\text{V}$)
- High Output Current ($I_o = 70\text{mA}$)
- Slew Rate ($3\text{V}/\mu\text{s}$ typ.)
- Gain Band Width Product (8MHz typ.)
- Package Outline DIP8, DMP8, SIP8, SSOP8
- Bipolar Technology

■ PACKAGE OUTLINE

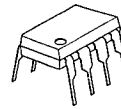

NJM4556AD



NJM4556AM

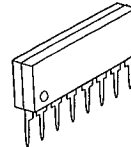

NJM4556AL



NJM4556AV

■ PIN CONFIGURATION

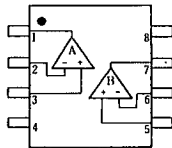

NJM4556AD.
NJM4556AM
NJM4556AV

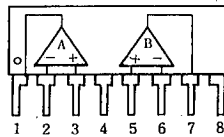

NJM4556AL

PIN FUNCTION

1. A OUTPUT
2. A-INPUT
3. A+INPUT
4. V-
5. B+INPUT
6. B-INPUT
7. B OUTPUT
8. V+

■ EQUIVALENT CIRCUIT (1/2 Shown)

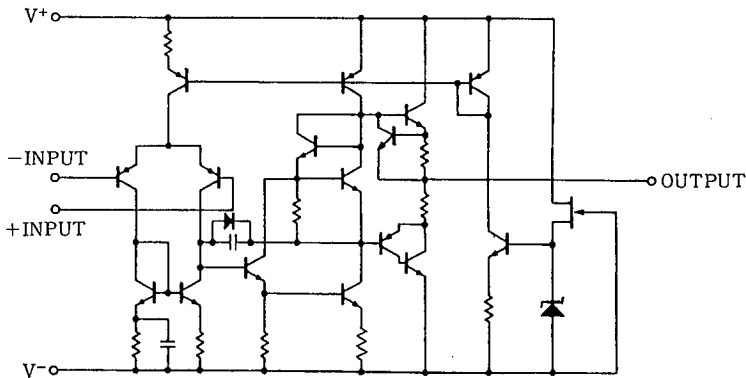

PIN CONFIGURATION

IC87 RE5VL28CATZ
IC85 RH5VT18C

IC , RESET
I.C , RESET

• TO-92

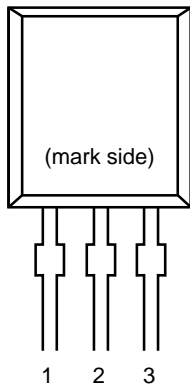

• SOT-89

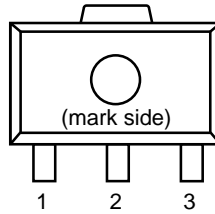

• SOT-23-5

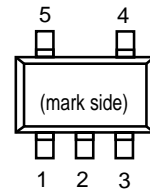

PIN DESCRIPTION

• TO-92

Pin No	Symbol
1	OUT
2	VDD
3	GND

• SOT-89

Pin No	Symbol
1	OUT
2	VDD
3	GND

• SOT-23-5

Pin No	Symbol
1	OUT
2	VDD
3	GND
4	NC
5	NC

BLOCK DIAGRAMS

• Nch Open Drain Output (R\times5VL\timesA)

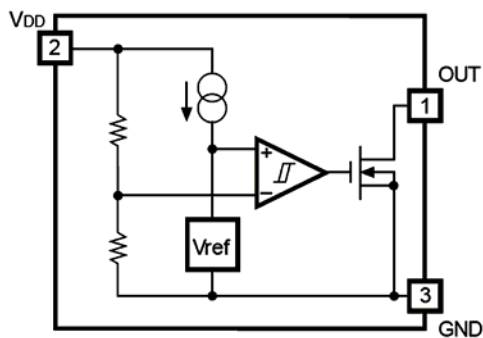

• CMOS Output (R\times5VL\timesC)

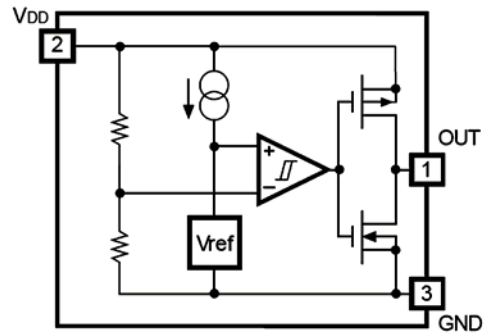

TC9162AF (FUNCTION/INPUT :

■ BLOCK DIAGRAM

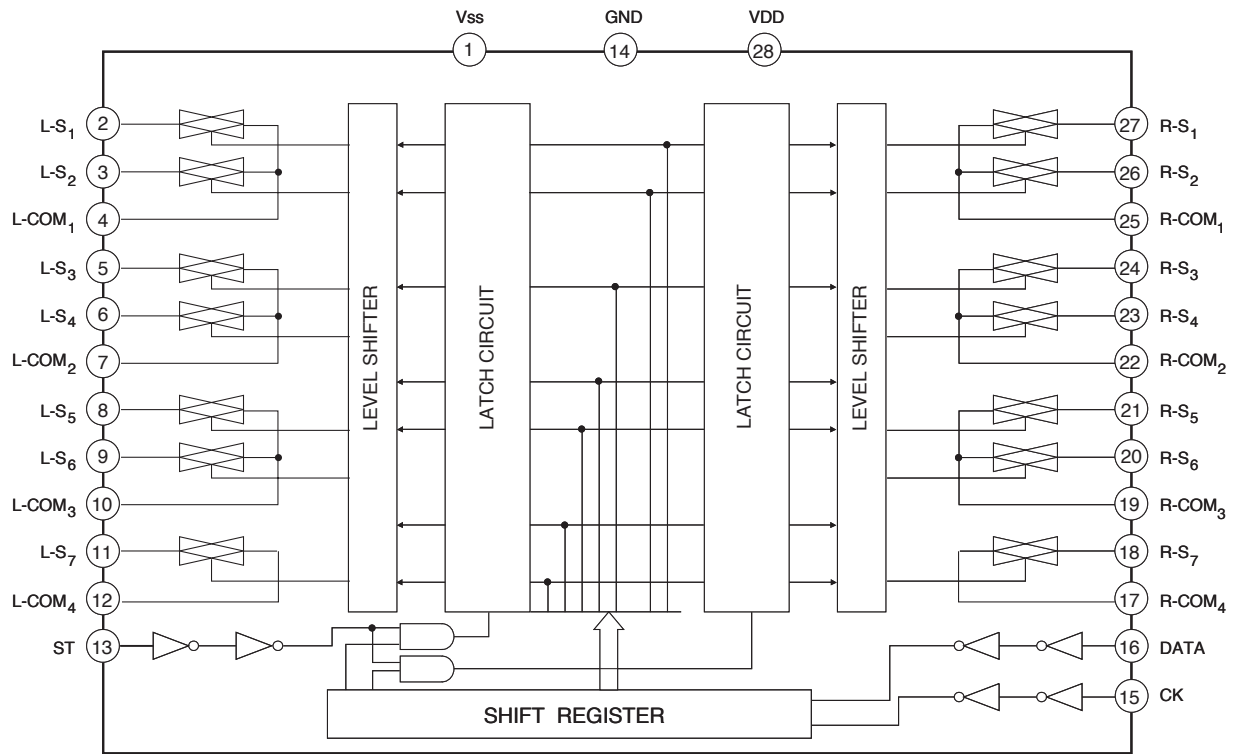

TC9164AF (FUNCTION/INPUT) : IC23

■ BLOCK DIAGRAM

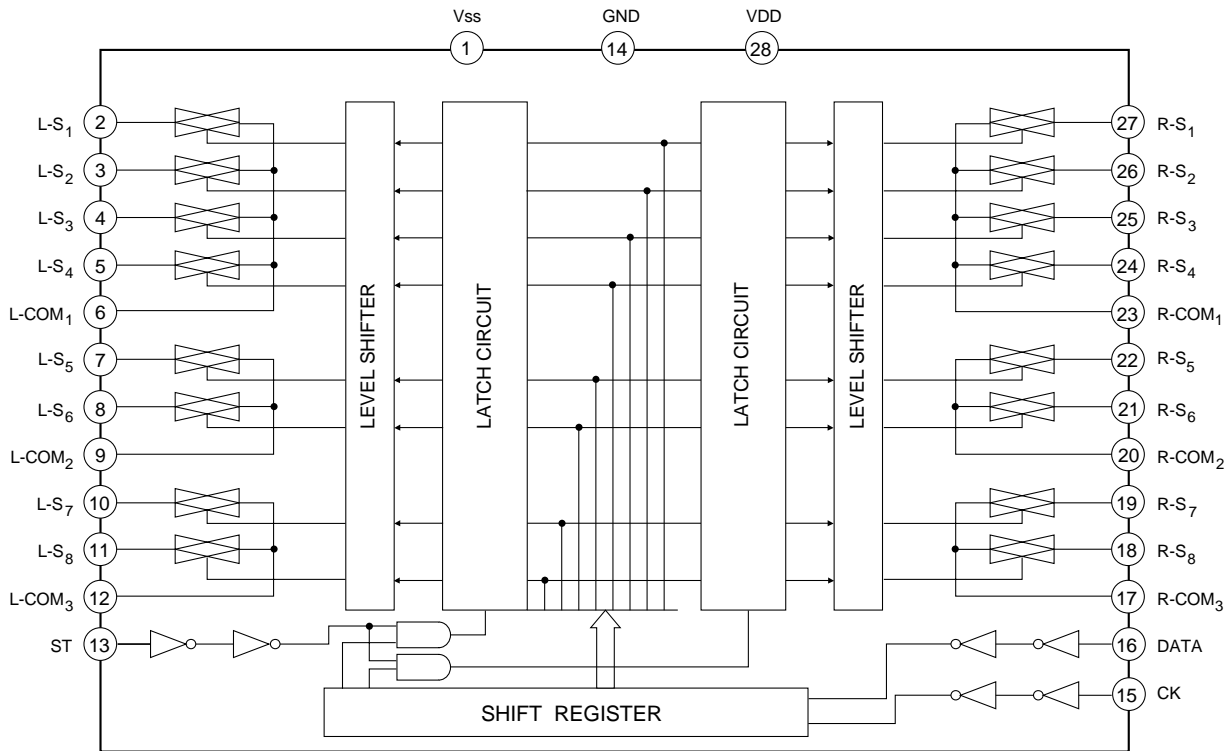

TC9163AF (FUNCTION/INPUT) : IC24

■ BLOCK DIAGRAM

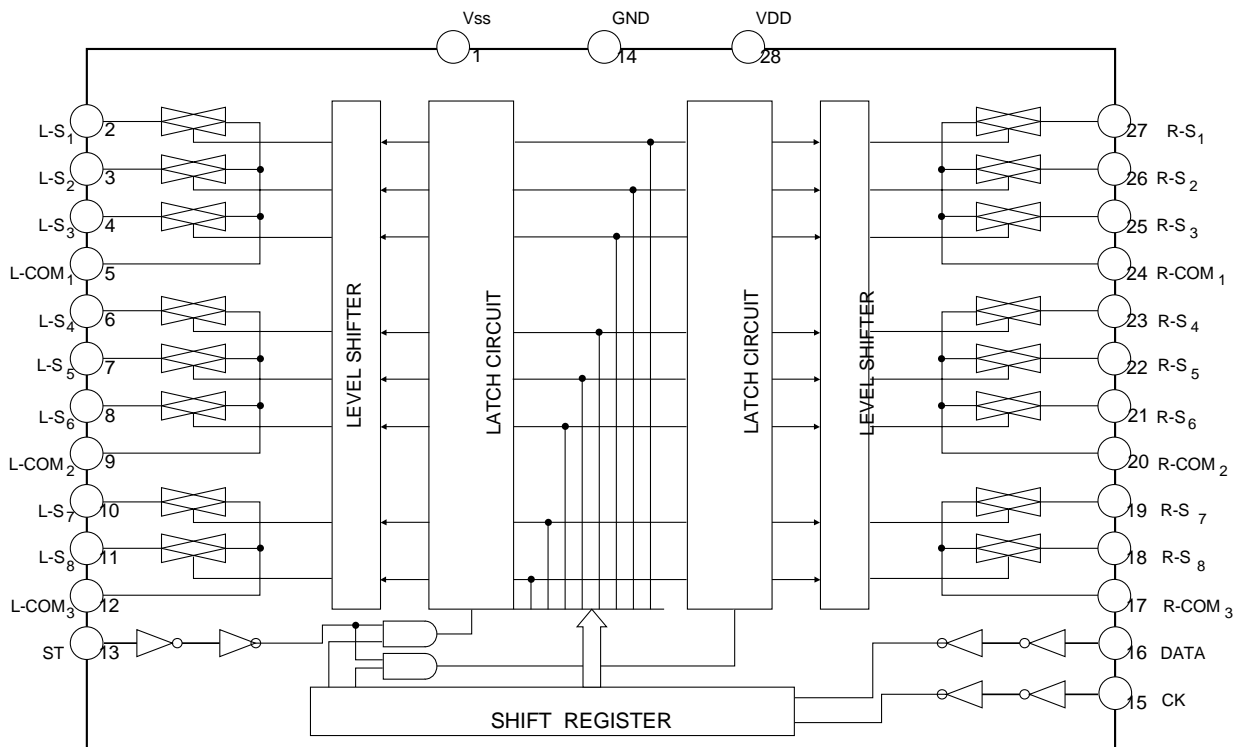

TOSHIBA

TC9214,15AP/AF

TOSHIBA CMOS DIGITAL INTEGRATED CIRCUIT SILICON MONOLITHIC

TC9214AP, TC9214AF, TC9215AP, TC9215AF

HIGH VOLTAGE ANALOG SWITCH

TC9214AP/AF, TC9215AP/AF are Analog Switch for high voltage audio application.

FEATURES

- Analog Switch Circuit Formation
 TC9214AP, TC9214AF : 5 circuits
 TC9215AP, TC9215AF : 6 circuits
- Dual Power Supply of (+) and (-) can be used.
- Including Level Shift Circuit, this IC can be operated by (+) power supply only under dual power supply operating.
- Setting Low Input-threshold-voltage in control signal input terminal. 5V CPU application can control this IC directly.
- Package : DIP-16 PIN
 SOP-16 PIN

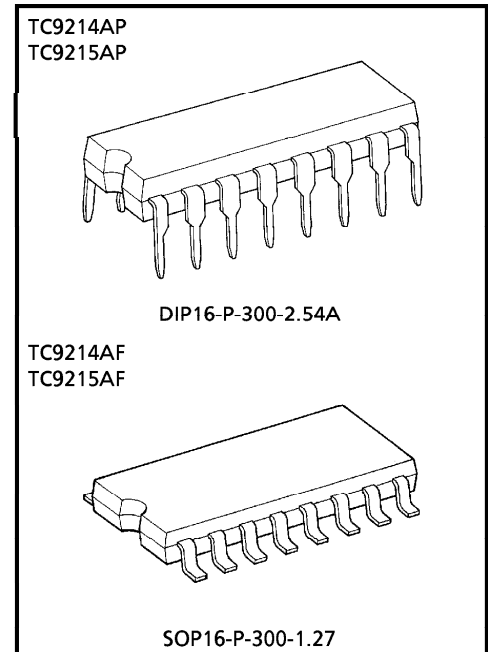

Weight
 DIP16-P-300-2.54A : 1.0g (Typ.)
 SOP16-P-300-1.27 : 0.16g (Typ.)

PIN CONNECTION (TOP VIEW)

TC9214AP, TC9214AF

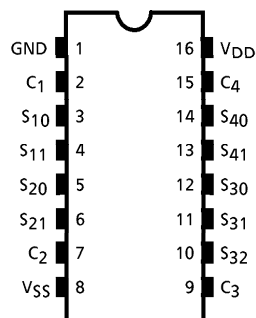

TC9215AP, TC9215AF

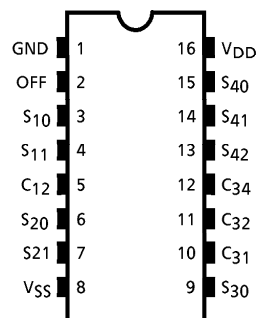

980508EBA2

TOSHIBA

TC9214,15AP/AF

BLOCK DIAGRAM

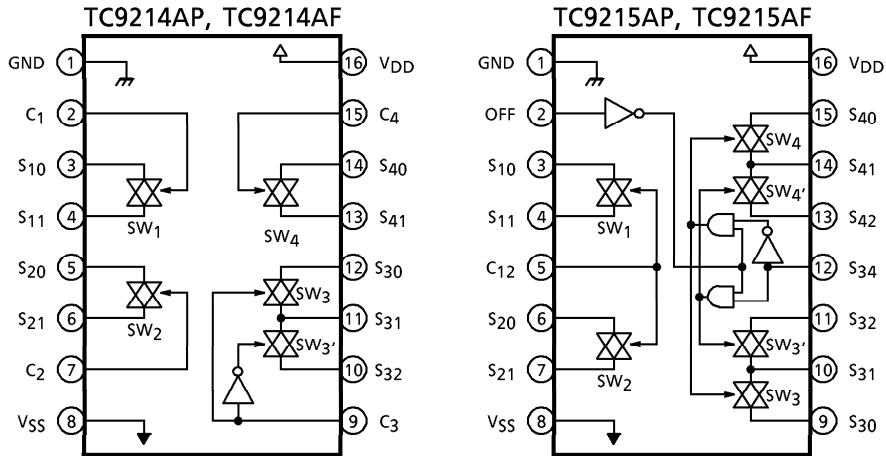

PIN FUNCTION

1. TC9214AP, TC9214AF

PIN No.	SYMBOL	PIN NAME	FUNCTION	NOTE																		
1	GND	Ground Terminal	Dual power supplying : + B →V _{DD} 0V →GND - B →V _{SS}	—																		
8	V _{SS}	(-) Power Supply Terminal																				
16	V _{DD}	(+) Power Supply Terminal																				
2	C ₁	Switch (1) Control Terminal	SWITCH CONNECTION TRUTH TABLE <table border="1" style="margin-left: auto; margin-right: auto;"> <tr> <td>C₁, C₂, C₄</td> <td colspan="2">SW₁, SW₂, SW₃</td> </tr> <tr> <td>H</td> <td colspan="2">ON</td> </tr> <tr> <td>L</td> <td colspan="2">OFF</td> </tr> </table> <table border="1" style="margin-left: auto; margin-right: auto;"> <tr> <td>C₃</td> <td>S₃₀-S₃₁</td> <td>S₃₁-S₃₂</td> </tr> <tr> <td>H</td> <td>ON</td> <td>OFF</td> </tr> <tr> <td>L</td> <td>OFF</td> <td>ON</td> </tr> </table>	C ₁ , C ₂ , C ₄	SW ₁ , SW ₂ , SW ₃		H	ON		L	OFF		C ₃	S ₃₀ -S ₃₁	S ₃₁ -S ₃₂	H	ON	OFF	L	OFF	ON	—
C ₁ , C ₂ , C ₄	SW ₁ , SW ₂ , SW ₃																					
H	ON																					
L	OFF																					
C ₃	S ₃₀ -S ₃₁	S ₃₁ -S ₃₂																				
H	ON	OFF																				
L	OFF	ON																				
3	S ₁₀	Switch (1) Input/ Output Terminal																				
4	S ₁₁																					
5	S ₂₀	Switch (2) Input/ Output Terminal																				
6	S ₂₁																					
7	C ₂	Switch (2) Control Terminal																				
9	C ₃	Switch (3) Control Terminal																				
10	S ₃₂	Switch (3) Input/ Output Terminal																				
11	S ₃₁																					
12	S ₃₀																					
13	S ₄₁	Switch (4) Input/ Output Terminal																				
14	S ₄₀																					
15	C ₄		Switch (4) Control Terminal																			

TOSHIBA**TC9214,15AP/AF**

2. TC9215AP, TC9215AF

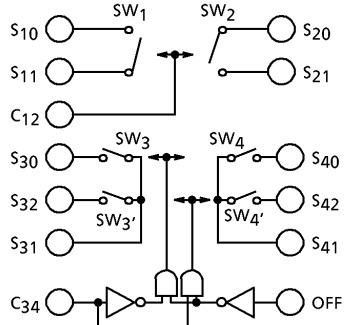
PIN No.	SYMBOL	PIN NAME	FUNCTION	NOTE																					
1	GND	Ground Terminal	Dual power supplying : + B →V _{DD} 0V →GND - B →V _{SS} Single power supplying: + B →V _{DD} 0V →GND, V _{SS}	—																					
8	V _{SS}	(-) Power Supply Terminal																							
16	V _{DD}	(+) Power Supply Terminal																							
2	OFF	Switch (3), (4) OFF Input Terminal	SWITCH CONNECTION  TRUTH TABLE <table border="1" data-bbox="726 1052 1189 1176"> <thead> <tr> <th>C12</th> <th>SW₁, SW₂</th> </tr> </thead> <tbody> <tr> <td>H</td> <td>ON</td> </tr> <tr> <td>L</td> <td>OFF</td> </tr> </tbody> </table> <table border="1" data-bbox="726 1220 1284 1377"> <thead> <tr> <th>OFF</th> <th>C34</th> <th>S₃₀-S₃₁ S₄₀-S₄₁</th> <th>S₃₁-S₃₂ S₄₁-S₄₂</th> </tr> </thead> <tbody> <tr> <td rowspan="2">L</td> <td>L</td> <td>ON</td> <td>OFF</td> </tr> <tr> <td>H</td> <td>OFF</td> <td>ON</td> </tr> <tr> <td>H</td> <td>※</td> <td>OFF</td> <td>OFF</td> </tr> </tbody> </table> (※ H or L)	C12	SW ₁ , SW ₂	H	ON	L	OFF	OFF	C34	S ₃₀ -S ₃₁ S ₄₀ -S ₄₁	S ₃₁ -S ₃₂ S ₄₁ -S ₄₂	L	L	ON	OFF	H	OFF	ON	H	※	OFF	OFF	—
C12	SW ₁ , SW ₂																								
H	ON																								
L	OFF																								
OFF	C34	S ₃₀ -S ₃₁ S ₄₀ -S ₄₁		S ₃₁ -S ₃₂ S ₄₁ -S ₄₂																					
L	L	ON		OFF																					
	H	OFF		ON																					
H	※	OFF		OFF																					
3	S ₁₀	Switch (1) Input / Output Terminal																							
4	S ₁₁																								
5	C ₁₂	Switch (1), (2) Control Terminal																							
6	S ₂₀	Switch (2) Input / Output Terminal																							
7	S ₂₁																								
9	S ₃₀	Switch (3) Input / Output Terminal																							
10	S ₃₁																								
11	S ₃₂																								
12	C ₃₄	Switch (3), (4) Control Terminal																							
13	S ₄₂	Switch (4) Input / Output Terminal																							
14	S ₄₁																								
15	S ₄₀																								

BLOCK DIAGRAM (TC9459F)

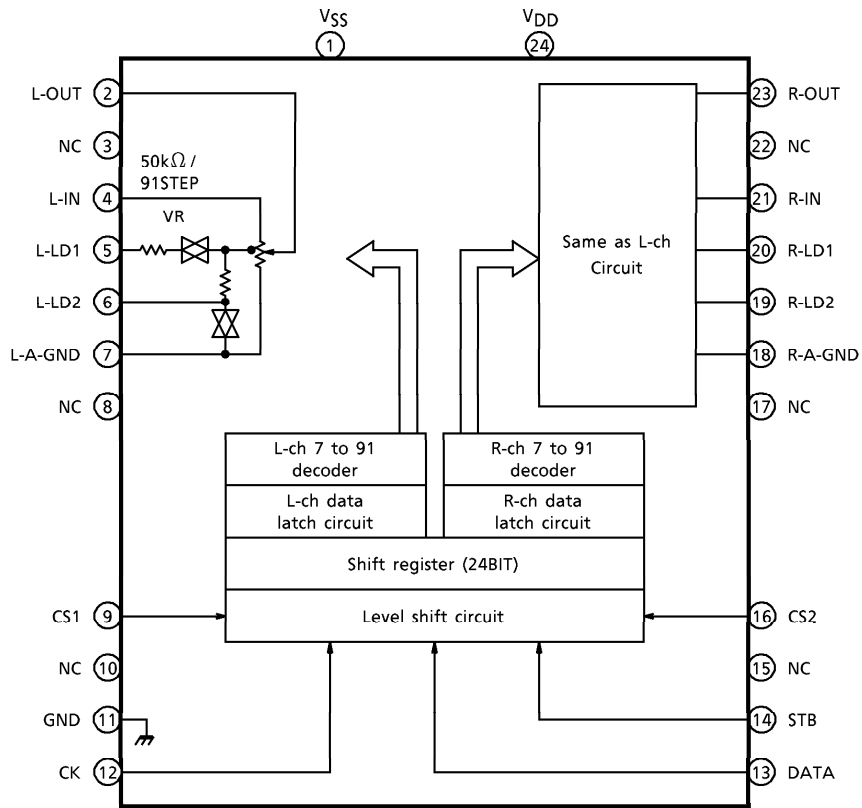

TOSHIBA**TC9459N/F****PIN DESCRIPTION**

Numeral in () means the pin No. of TC9459F.

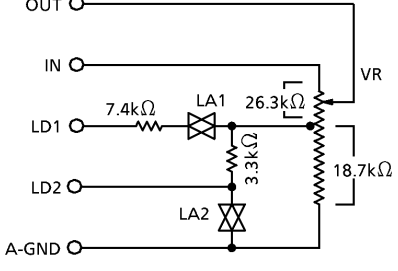
PIN No.	SYMBOL	PIN NAME	FUNCTION	REMARK										
1 (1)	V _{SS}	Negative power supply pin	When using dual power supplies <ul style="list-style-type: none"> — V_{DD} = 6.0~17V — GND = 0V — V_{SS} = -6.0~ -17V When using a single power supply <ul style="list-style-type: none"> — V_{DD} = 6.0~18V — GND = V_{SS} = 0V 	—										
28 (24)	V _{DD}	Positive power supply pin												
13 (11)	GND	Digital GND pin												
3 (2)	L-OUT	Volume output pin	• Volume circuit 	—										
26 (23)	R-OUT													
5 (4)	L-IN	Volume input pin												
24 (21)	R-IN													
6 (5)	L-LD1	Loudness tap output pin			<table border="1" style="margin-left: auto; margin-right: auto;"> <tr> <td style="width: 50%;"></td> <td style="width: 25%;">LA1</td> <td style="width: 25%;">LA2</td> </tr> <tr> <td>LOUDNESS "ON"</td> <td>ON</td> <td>OFF</td> </tr> <tr> <td>LOUDNESS "OFF"</td> <td>OFF</td> <td>ON</td> </tr> </table>		LA1	LA2	LOUDNESS "ON"	ON	OFF	LOUDNESS "OFF"	OFF	ON
	LA1					LA2								
LOUDNESS "ON"	ON					OFF								
LOUDNESS "OFF"	OFF					ON								
23 (20)	R-LD1													
7 (6)	L-LD2													
22 (19)	R-LD2													
8 (7)	L-A-GND	Analog GND pin												
21 (18)	R-A-GND													
10 (9)	CS1	Chip select input pin	Up to 4 chips on the same bus can be used by switching over chip select code.	—										
19 (16)	CS2													
14 (12)	CK	Clock input pin	Data transfer clock input	Low threshold value input pin										
15 (13)	DATA	Data input pin	Volume setup serial data input											
16 (14)	STB	Strobe input pin	Data write strobe input											
2 (3)	NC	No connection	—	—										
27 (22)														
4														
25														
9 (8)														
20 (17)														
11														
18														
12 (10)														
17 (15)														

TOSHIBA

TC9482BNG/BFG

TOSHIBA CMOS DIGITAL INTEGRATED CIRCUIT SILICON MONOLITHIC

TC948BNG, TC9482BFG**SYSTEM ELECTRONIC VOLUME CONTROL**

The TC9482BNG and TC9482BFG are six-channel electronic volume control ICs developed for Hi-Fi audio equipment. Since all six channels can be individually controlled, the devices are optimum for audio equipment with multiple outputs.

FEATURES

- Sound volume can be controlled in 97 steps from 0 to -95dB or up to an infinite level in 1dB increments.
- Incorporating six channels of volume control circuits, the device allows independent volume control.
- Can operate with a single or dual power supplies.
- Can control up to 4 chips on the same bus by using chip select input.
- Built-in interface for 3-V microcomputers.
- Thanks to its polysilicon resistor, the device allows you to configure a low-distortion, high-performance volume control system.
- Two packages supported: 28-pin shrink DIP and 28-pin flat package.

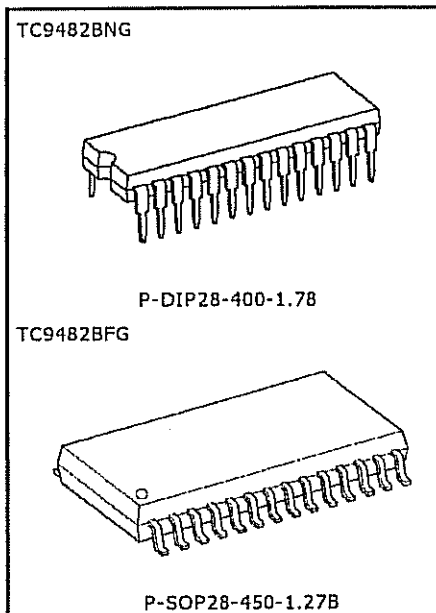

Weight
 P-SDIP28-400-1.78 : 2.2 g (Typ.)
 P-SOP28-450-1.27B : 0.8 g (Typ.)

TOSHIBA

TC9482BNG/BFG

PIN CONNECTIONS

V _{SS}	1	28	V _{DD}
NC	2	27	TEST
L-OUTA	3	26	R-OUTA
L-INA	4	25	R-INA
L-A-GNDA	5	24	R-A-GNDA
L-OUTB	6	23	R-OUTB
L-INB	7	22	R-INB
L-A-GNDB	8	21	R-A-GNDB
L-OUTC	9	20	R-OUTC
L-INC	10	19	R-INC
L-A-GNDC	11	18	R-A-GNDC
CS1	12	17	CS2
GND	13	16	STB
CK	14	15	DATA

BLOCK DIAGRAM

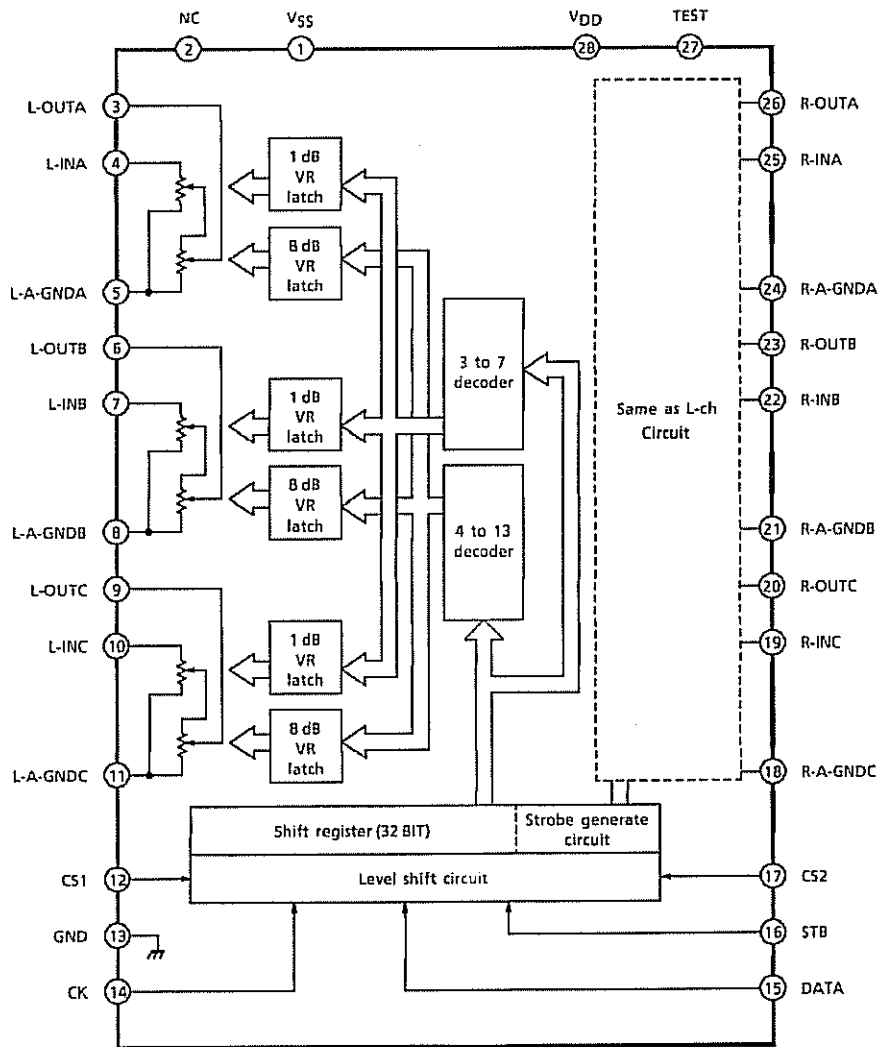

TOSHIBA

TC9482BNG/BFG

PIN DESCRIPTION

PIN No.	SYMBOL	PIN NAME	FUNCTION	REMARK
1	V _{SS}	Negative power supply pin	• Power Supply Pins	—
28	V _{DD}	Positive power supply pin		
3	L-OUTA	Volume output pin	• Volume circuit	—
26	R-OUTA			
6	L-OUTB			
22	R-OUTB			
9	L-OUTC			
19	R-OUTC			
4	L-INA	Volume input pin		—
25	R-INA			
7	L-INB			
22	R-INB			
10	L-INC			
19	R-INC			
5	L-A-GNDA	Analog GND pin		—
24	R-A-GNDA			
8	L-A-GNDB			
21	R-A-GNDB			
11	L-A-GNDC			
18	R-A-GNDC			
12	CS1	Chip select input pin	Up to 4 chips on the same bus can be used by switching over chip select code.	—
17	CS2			
14	CK	Clock input pin	Inputs clock for serial data transfer.	Low threshold value input pin
15	DATA	Data input pin	Inputs control data for setting volume.	
16	STB	Strobe input pin	Inputs strobe for writing data.	
13	GND	Digital GND pin	Digital ground pin	—
27	TEST	Test Pin	Normally connect to V _{DD} pin.	—
2	NC	No connection	—	—



M29W800DT M29W800DB

8 Mbit (1Mb x8 or 512Kb x16, Boot Block)
3V Supply Flash Memory

FEATURES SUMMARY

- SUPPLY VOLTAGE
 - $V_{CC} = 2.7V$ to $3.6V$ for Program, Erase and Read
- ACCESS TIME: 70, 90ns
- PROGRAMMING TIME
 - $10\mu s$ per Byte/Word typical
- 19 MEMORY BLOCKS
 - 1 Boot Block (Top or Bottom Location)
 - 2 Parameter and 16 Main Blocks
- PROGRAM/ERASE CONTROLLER
 - Embedded Byte/Word Program algorithms
- ERASE SUSPEND and RESUME MODES
 - Read and Program another Block during Erase Suspend
- UNLOCK BYPASS PROGRAM COMMAND
 - Faster Production/Batch Programming
- TEMPORARY BLOCK UNPROTECTION MODE
- COMMON FLASH INTERFACE
 - 64 bit Security Code
- LOW POWER CONSUMPTION
 - Standby and Automatic Standby
- 100,000 PROGRAM/ERASE CYCLES per BLOCK
- ELECTRONIC SIGNATURE
 - Manufacturer Code: 0020h
 - Top Device Code M29W800DT: 22D7h
 - Bottom Device Code M29W800DB: 225Bh

Figure 1. Packages

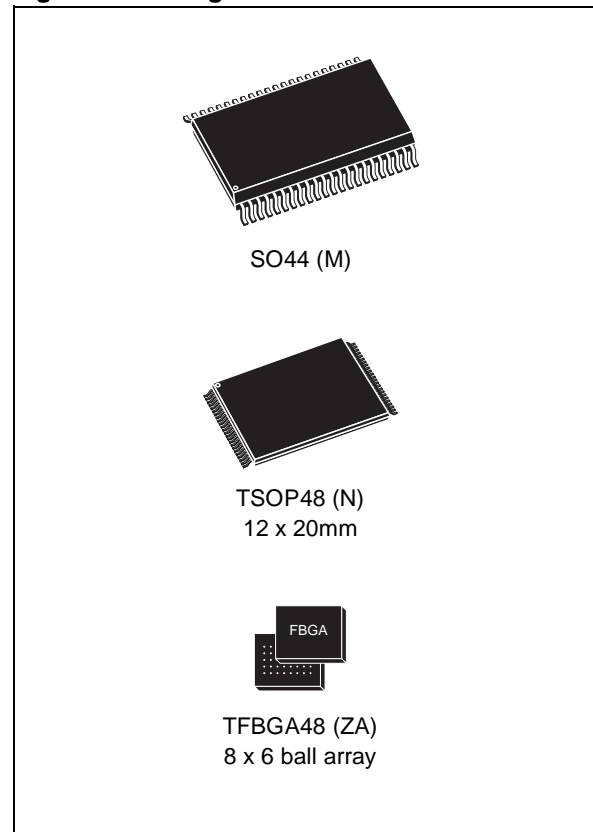

M29W800DT, M29W800DB

Figure 3. SO Connections

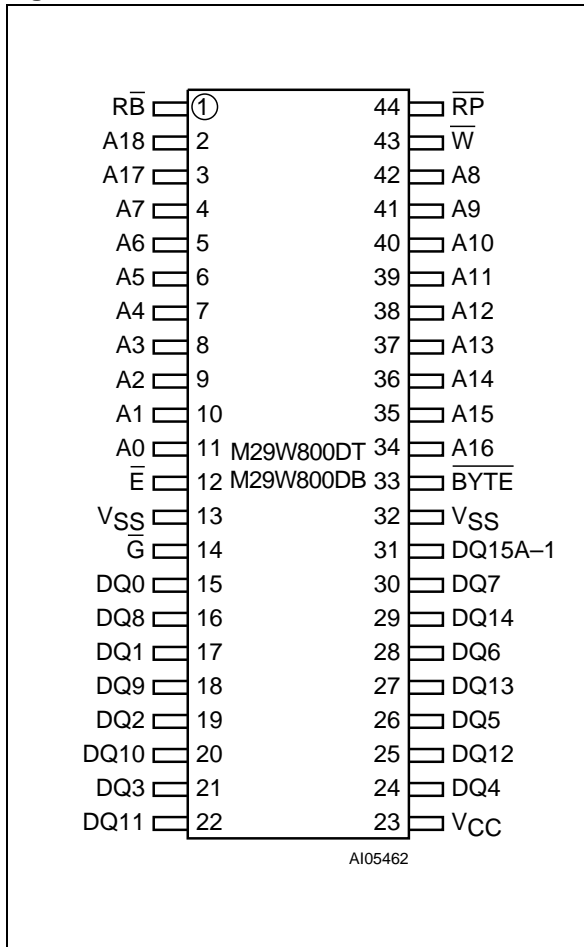
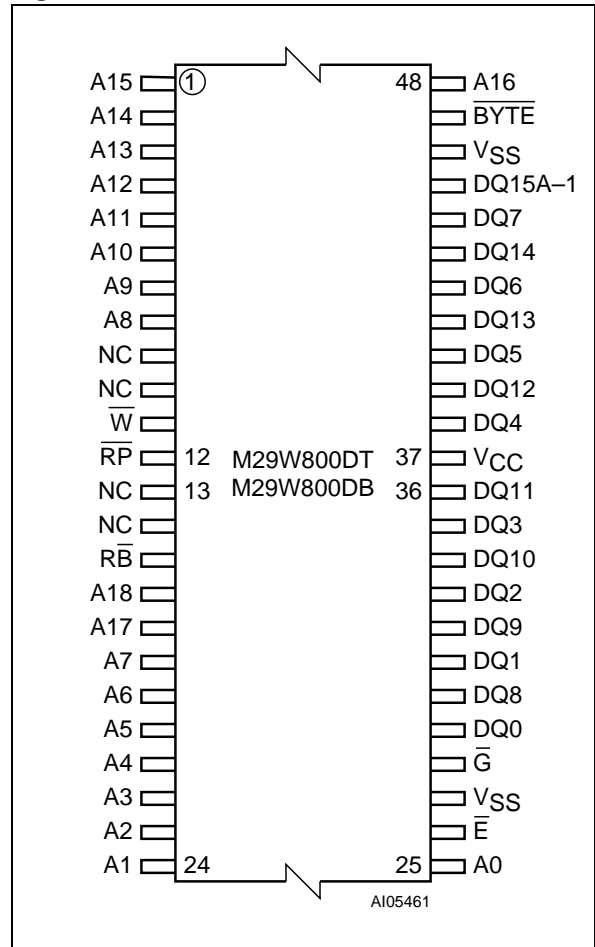

Figure 4. TSOP Connections



NJM2586AM

[WIDE BAND 3-INPUT 1-OUTPUT 3-CIRCUIT VIDEO AMPLIFIER]

[STRUCTURE] Bipolar
 [CATEGORIES] TV-Video
 [PACKAGE OUTLINE] DMP-24
 [SOLDERING METHOD] For this device, soldering method is recommended Reflow.
 [NOTE] -

BAE-38461-000-01

■ **ABSOLUTE MAXIMUM RATINGS** $T_a=25^{\circ}\text{C}$

Supply Voltage	±6.0 [V]	Operating Temperature Range	-40 to +85 [°C]
Power Dissipation	500 [mW]	Storage Temperature Range	-40 to +125 [°C]

■ **BLOCK DIAGRAM**

BDE-33546-000-00

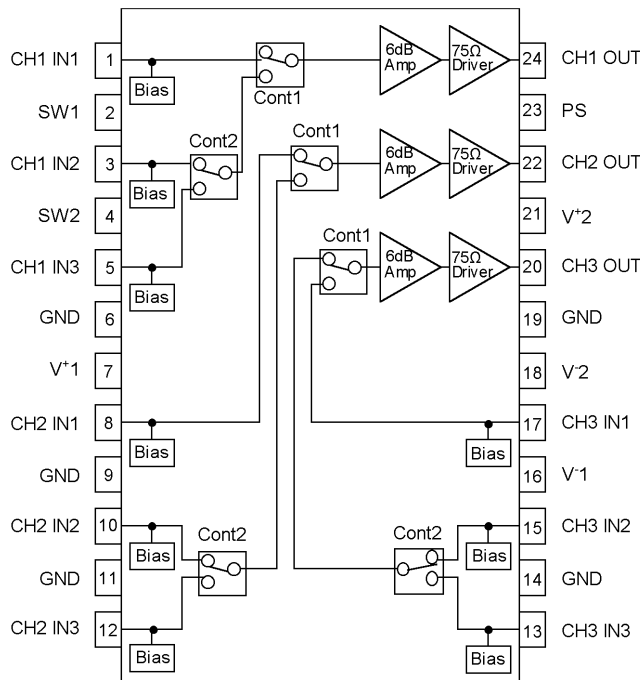





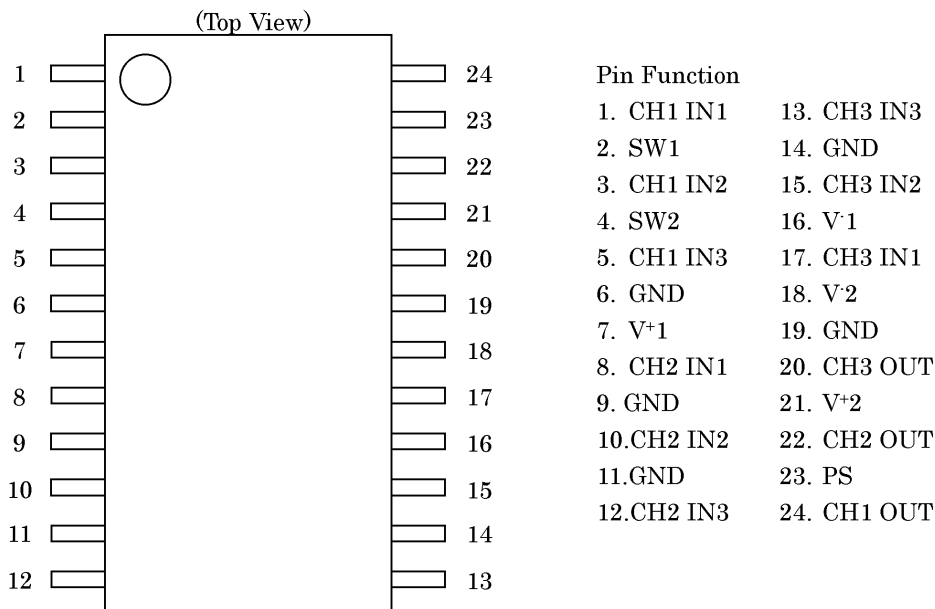

■ **PIN CONFIGURATION**

BEE-33546-000-01

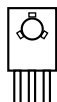

TRANSISTOR, REGULATOR IC BLOCK DIAGRAM

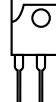
<p>TO-92M</p>  <p>1. Emitter 2. Collector 3. Base</p> <p>123</p> <p>KTC2874B KSC2785Y KRA107M KRC107M KRA104MT KRC104M</p>	<p>TO-92</p>  <p>1. Emitter 2. Collector 3. Base</p> <p>123</p> <p>KTD1302T KTA1268GR KTC3200GR KTC3198Y KTA1271Y KSA1175YT</p>	<p>TO-220</p>  <p>1. GND 2. INPUT 3. OUTPUT</p> <p>123</p> <p>MCNJM7905 MC7915C L7905 L7915</p>	<p>TO-92L</p>  <p>1. Emitter 2. Collector 3. Base</p> <p>123</p> <p>KTA1024Y KSC2316Y</p>
<p>TO-126</p>  <p>1. Emitter 2. Collector 3. Base</p> <p>123</p> <p>2SA1360O 2SC3423O KTD600KG</p>	<p>TO-92</p>  <p>1. Emitter 2. Base 3. Collector</p> <p>123</p> <p>KSA733CYT</p>	<p>TO-220</p>  <p>1. INPUT 2. GND 3. OUTPUT</p> <p>123</p> <p>MC7815C MC7805C MC7809 L7805 NJM7824 L7815</p>	<p>TO-3P</p>  <p>1. Base 2. Collector 3. Emitter</p> <p>1 2 3</p> <p>2SB1560 2SD2390 2SA1360 2SB1647</p>

**NJM2391DL1-25 NJM2391DL1-33
LOW DROPOUT VOLTAGE REGULATOR**

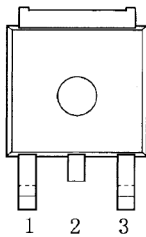

PIN FUNCTION
1. IN
2. GND
3. OUT

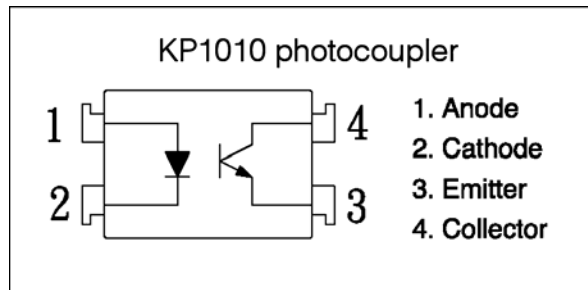
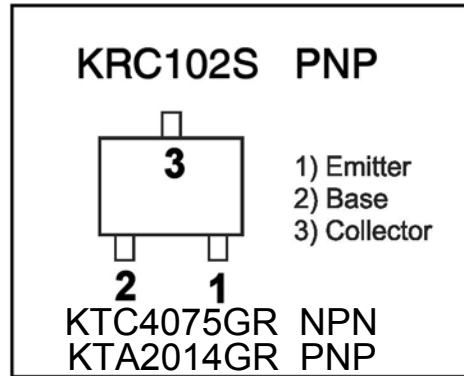

CUP11835

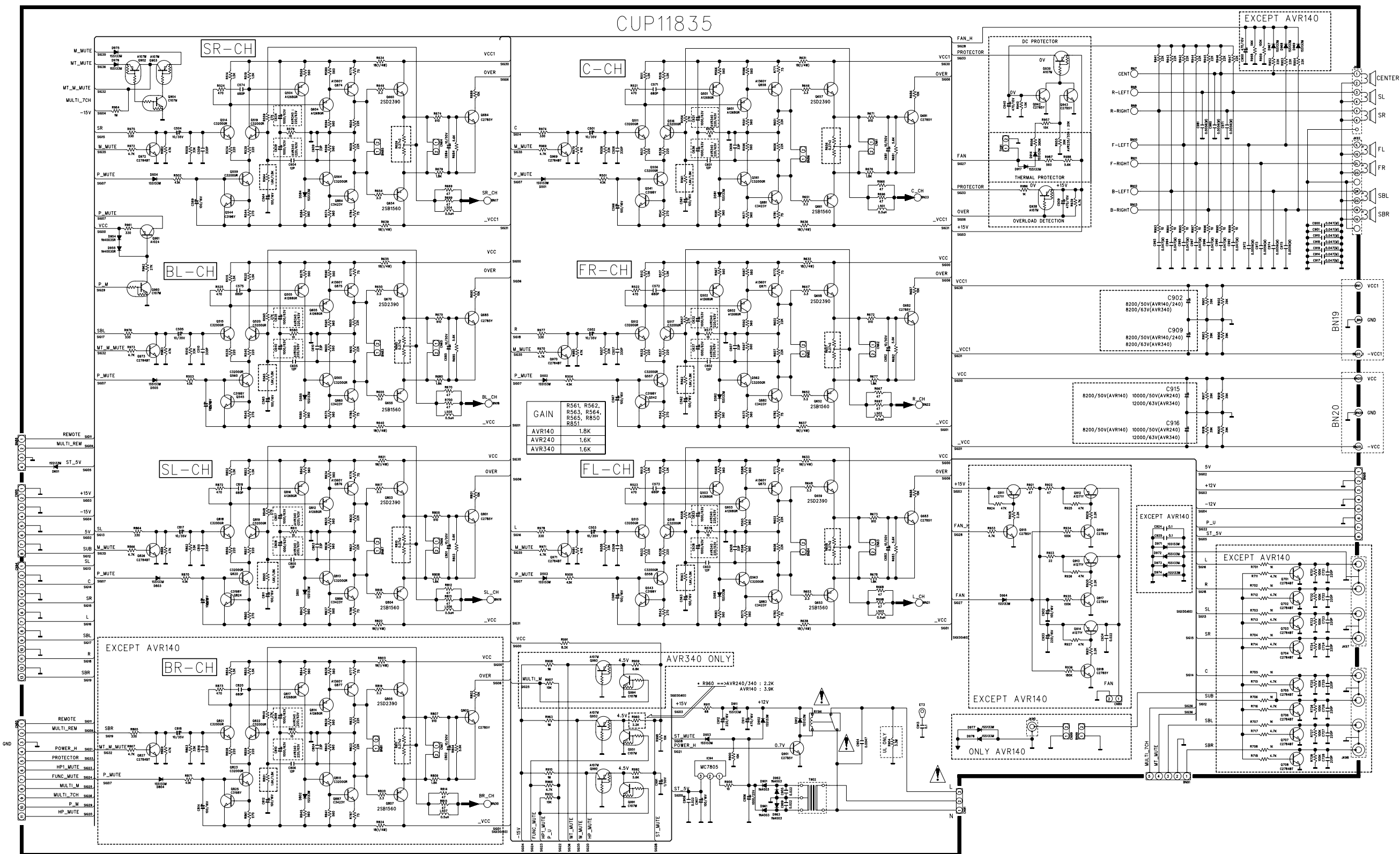

IMPORTANT SAFETY NOTICE.
 IMPORTANT FOR SAFETY WHEN REPLACING ANY OF THESE COMPONENTS
 USE ONLY MANUFACTURER'S SPECIFIED PARTS.
 THE UNIT OF RESISTANCE IS OHM.
 K=1000 OHM, M=1000 KOHM.
 THE UNIT OF CAPACITANCE IS MICROFARAD (uF)
 uF = 10⁻⁶ F
 THIS SCHEMATIC DIAGRAM MAY MODIFIED AT ANY TIME WHILE THE
 IMPROVEMENT OF PERFORMANCE

M/P

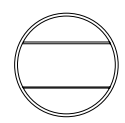

REVISION	1	2	3	SHEET
SCHEMATIC DIAGRAM				2
MODEL	AVR140, AVR240, AVR340			8
DESIGN	CHECK	APPROVE	DRAWING NO	
L.C.B	Y.W.Y	L.H.W	1835SCMZ	
05.05.24			(MAIN)	

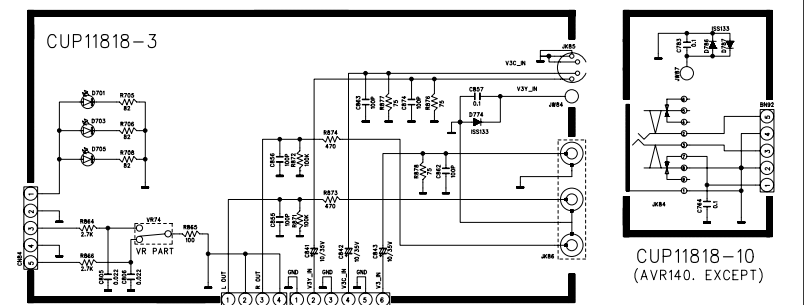
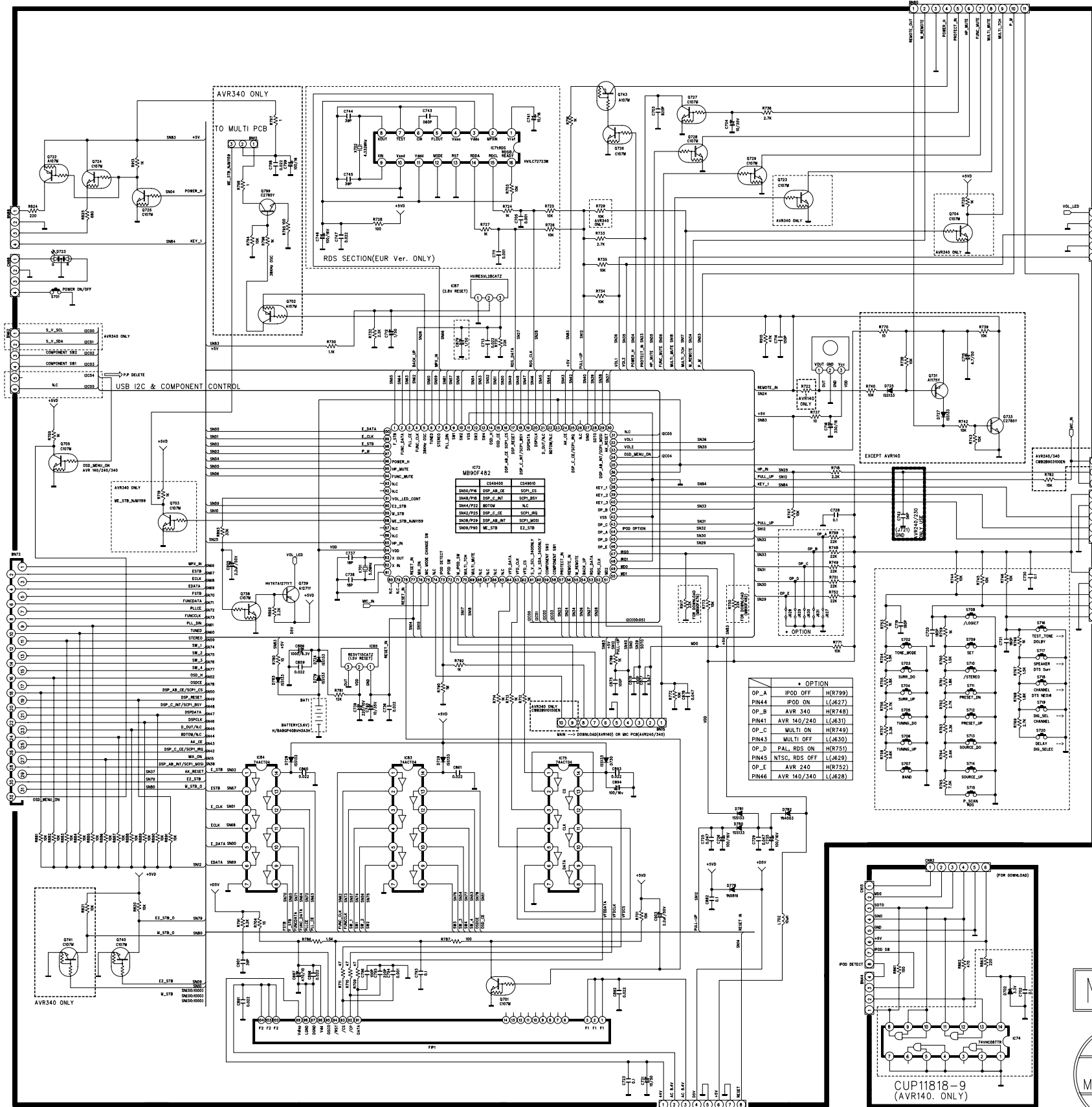

CUP11818-10 (AVR140. EXCEPT)

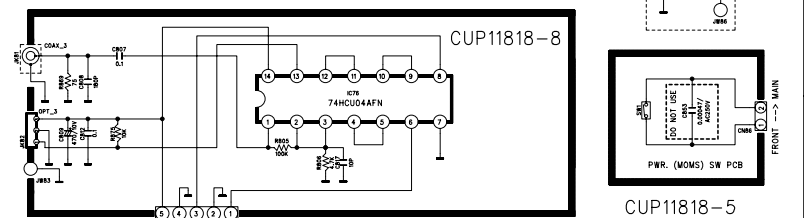

CUP11818-5

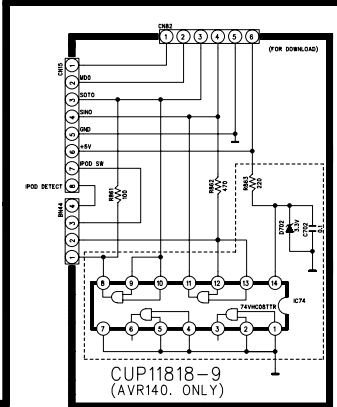
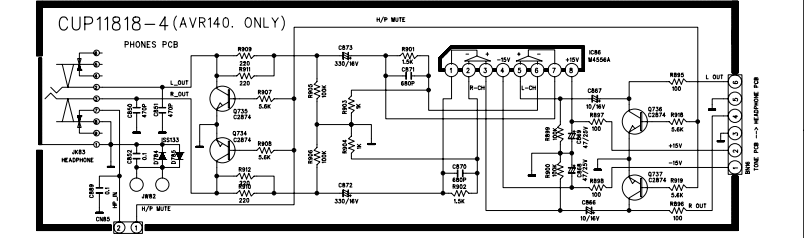
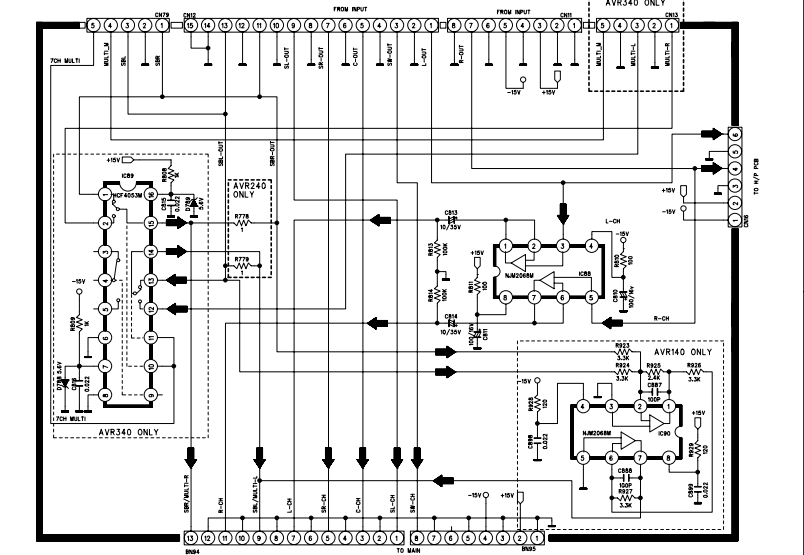

M/P

ISSUE
ANAM
MULTI LAB
2005.08.20

REVISION	2	4	6
1	3	5	7
SCHEMATIC DIAGRAM			
MODEL	AVR140/240/340		
DESIGN	CHECK	APPROVE	DRAWING NO
C.H.C	Y.W.Y	LEE H W	1818SCMZ
05.06.23			(FRONT)

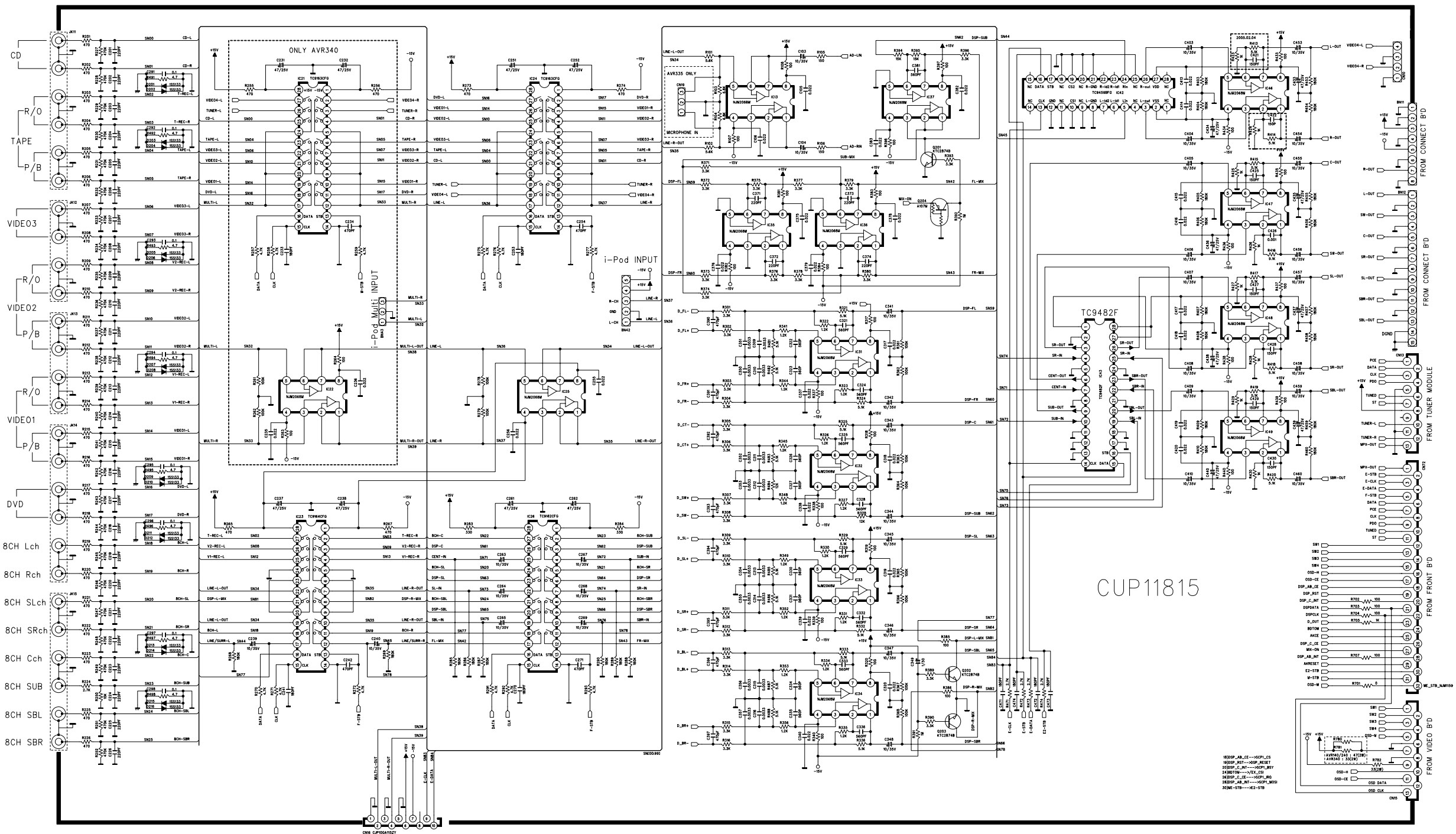

•• IMPORTANT SAFETY NOTICES.
 COMPONENTS IDENTIFIED BY Δ MARK HAVE SPECIAL CHARACTERISTICS.
 IMPORTANT FOR SAFETY, WHEN REPLACING ANY OF THESE COMPONENTS
 USE ONLY MANUFACTURER'S SPECIFIED PARTS.
 •• THE UNIT OF RESISTANCE IS OHM.
 K=1000 OHM , M=1000 KOHM
 •• THE UNIT OF CAPACITANCE IS MICROFARAD. (uF)
 pF=10⁻⁶ uF
 •• THIS SCHEMATIC DIAGRAM MAY MODIFIED AT ANY TIME WITH THE
 IMPROVEMENT OF PERFORMANCE.

M/P

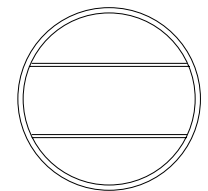

REVISION	2	4	6
1	3	5	7
SCHEMATIC DIAGRAM			SHEET
MODEL	AVR140/240/340		3/6
DESIGN	CHECK	APPROVE	DRAWING NO
K.M.S	Y.W.Y	L.H.W	1815SCPZ
04.02.20			(INPUT)

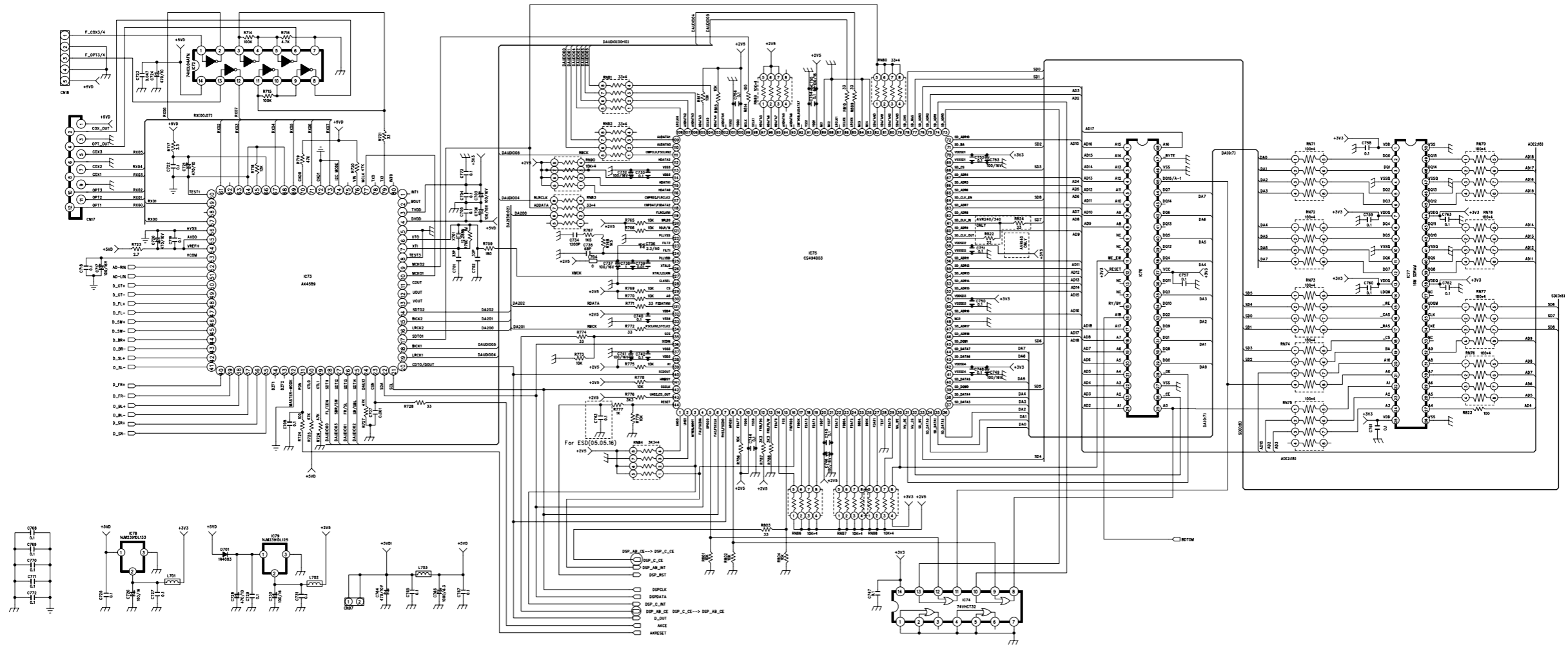

CUP11815

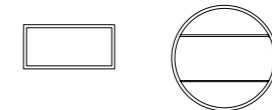

REVISION	2	4	6	
	3	5	7	
SCHMATIC DIAGRAM				SHEET
MODEL	AVR140/240/340			
DESIGN	CHECK	APPROVE	DRAWING NO	
Y.W.Y	Y.W.Y	L.H.W	1815SCPZ	

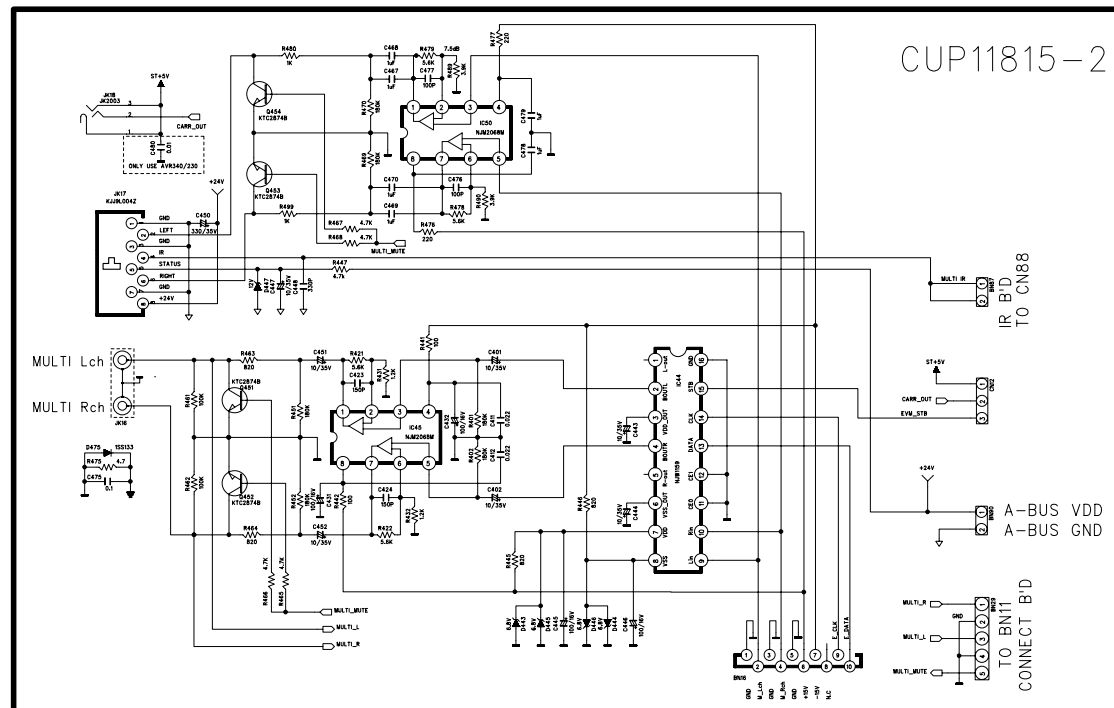
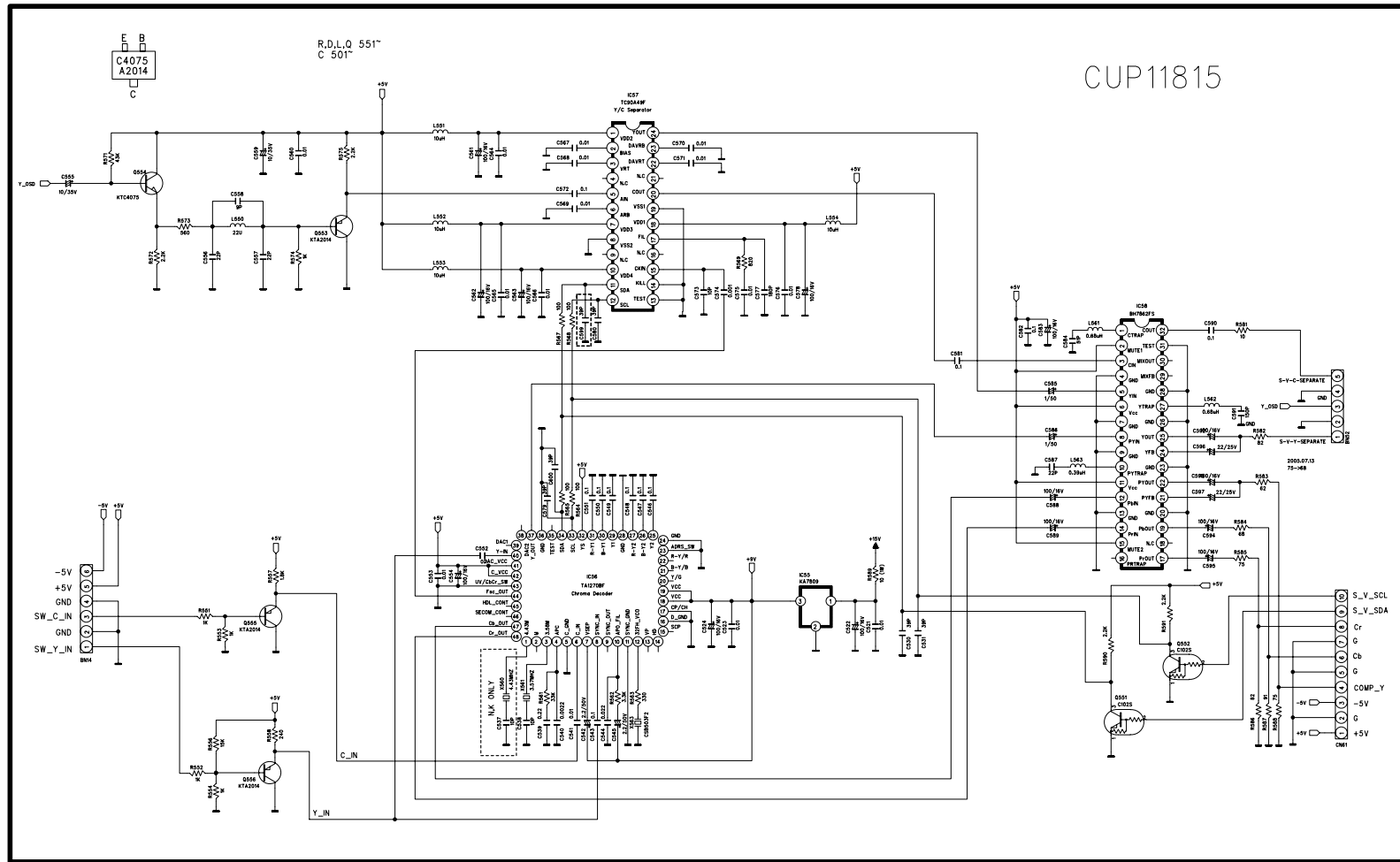

REVISION	2	4	6
1	3	5	7
SCHEMATIC DIAGRAM			SHEET
MODEL	AVR340		1/4
DESIGN	CHECK	APPROVE	DRAWING NO
Y.K.Y	Y.K.Y	Y.K.Y	1815SCPZ
05.00.00	05.00.00	05.00.00	ETC

CUP11834Z

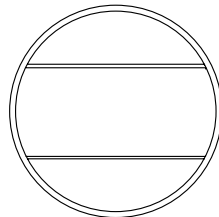
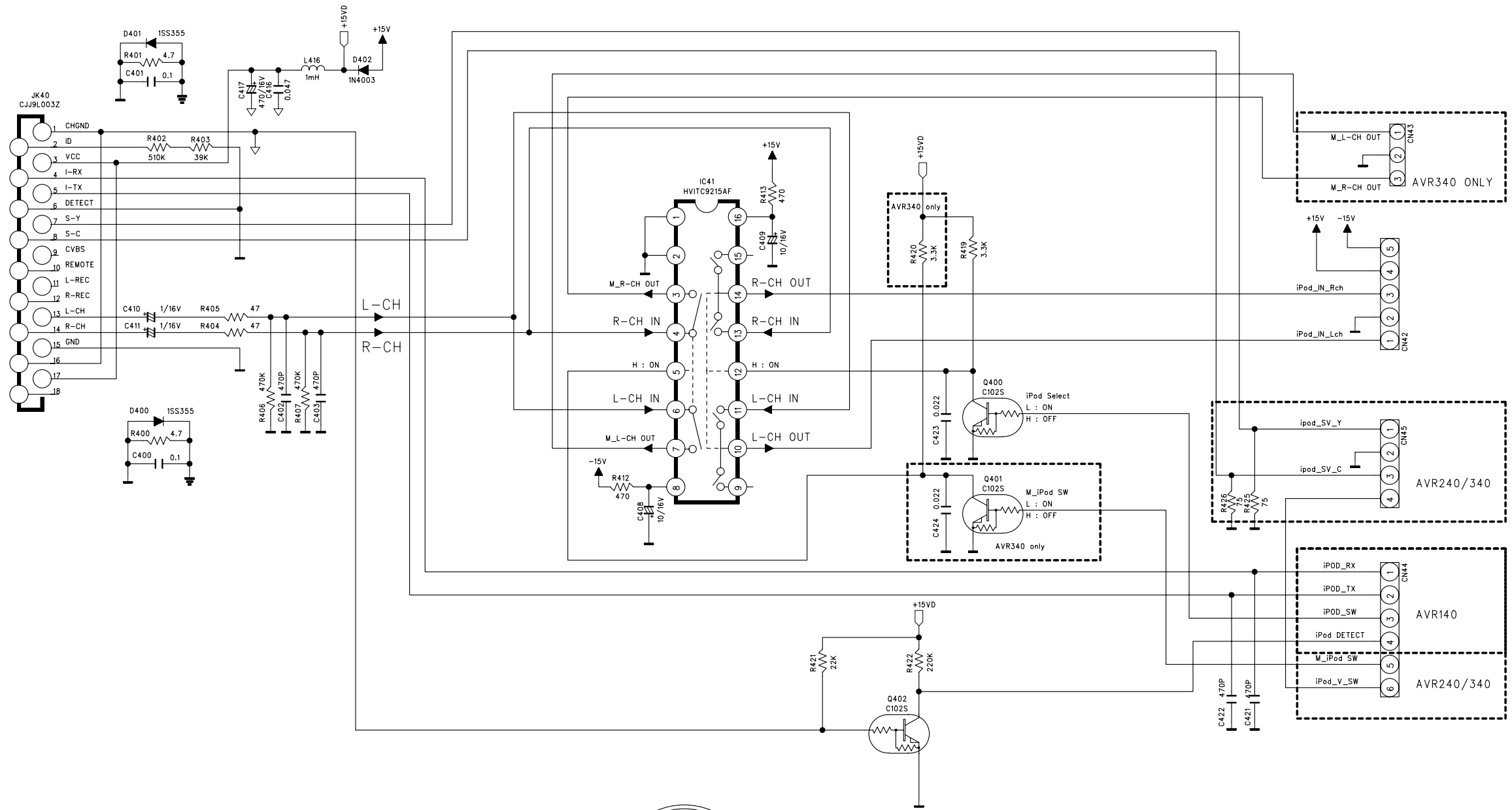

M/P

REVISION	2	4	6	
1	3	5	7	
SCHEMATIC DIAGRAM				SHEET
MODEL	AVR140/240/340			2 4
DESIGN	CHECK	APPROVE	DRAWING NO	
L.J.Y	Y.W.Y	L.H.W	1834SCMZ	
05.06.28	05.06.28		(DMP)	1 1

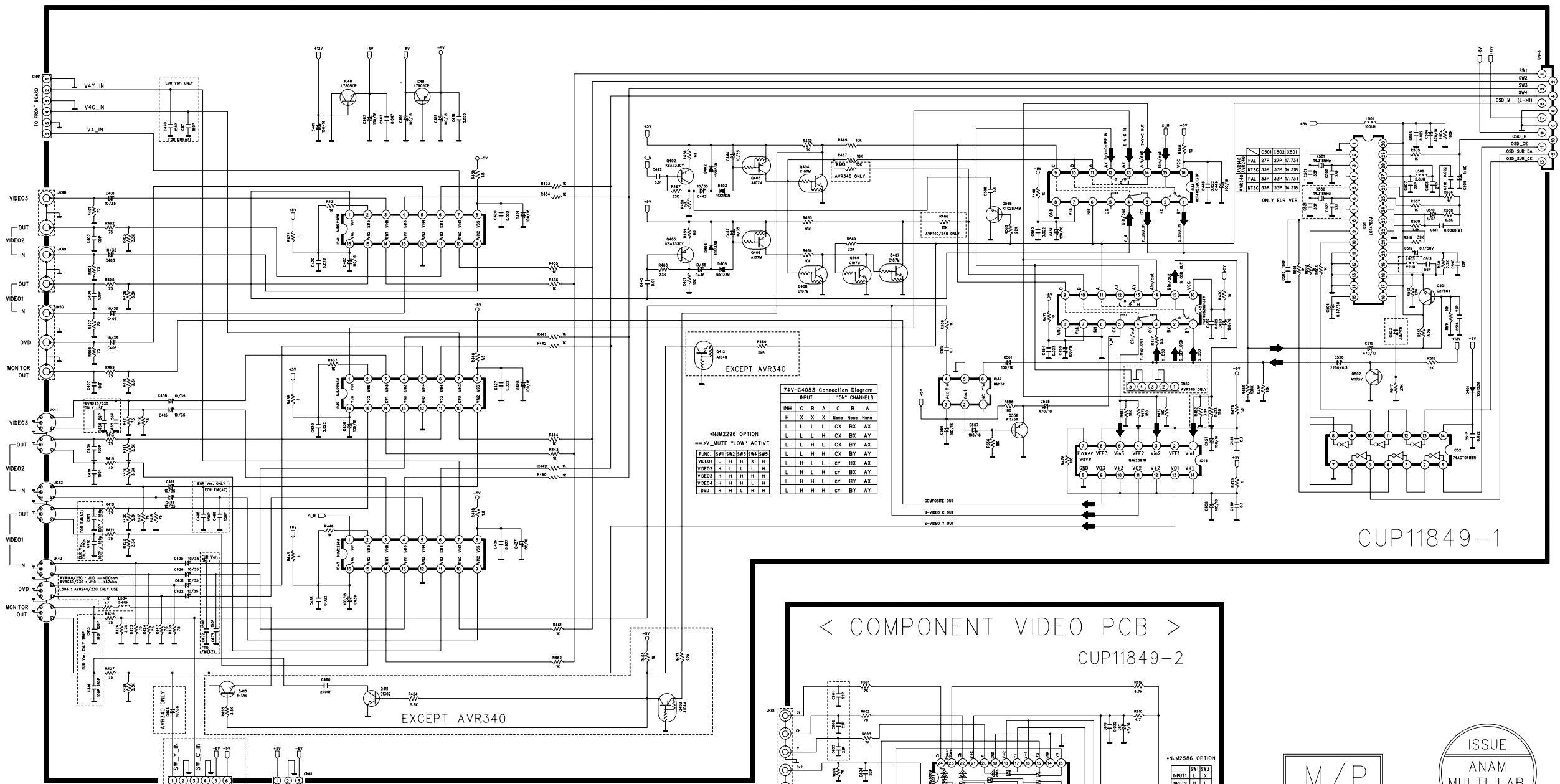

CUP11849-1

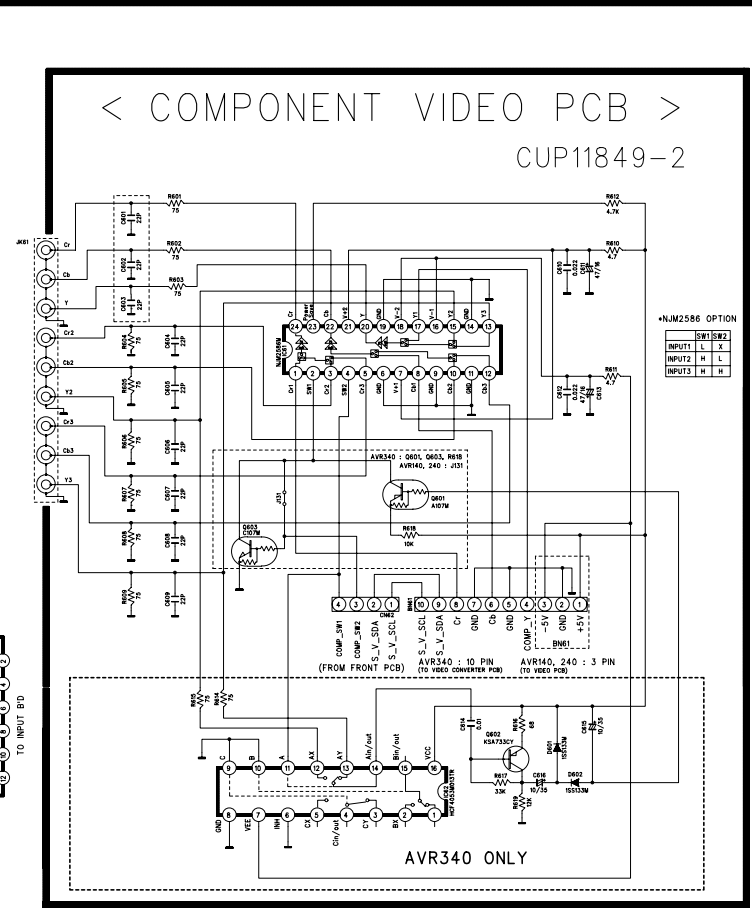

M/P

ISSUE
ANAM
MULTI LAB
2005.8.20

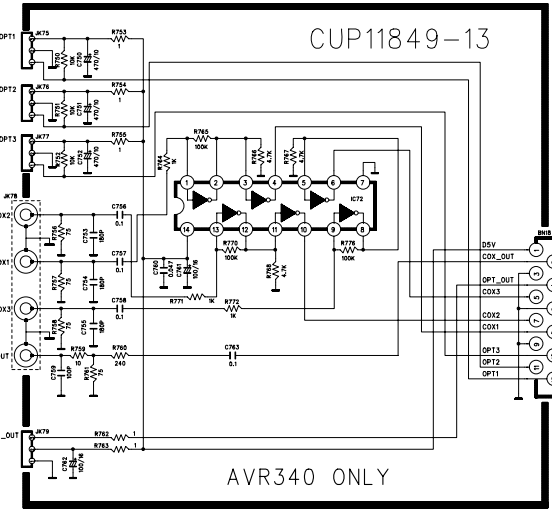
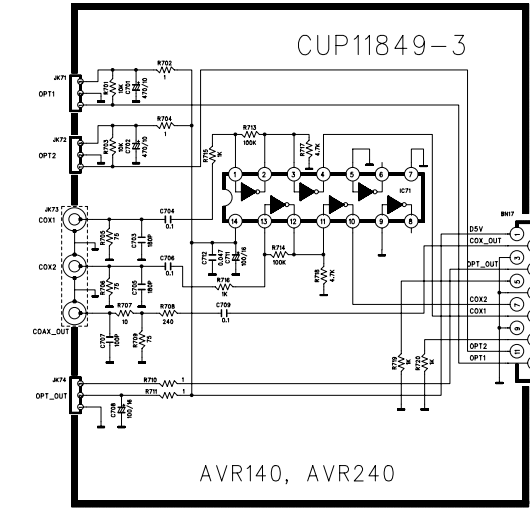

REVISION	2	4	6
1	3	5	7
SCHEMATIC DIAGRAM			
MODEL	AVR140, AVR240, AVR340		
DESIGN	CHECK	APPROVE	DRAWING NO
LEE C B	Y.W.Y	L.H.W	1849SCMZ (VIDEO)
05.02.01			

6

5

4

3

2

1

< BIAS T.R PCB >

< POWER TRANS & OUTLET PCB >

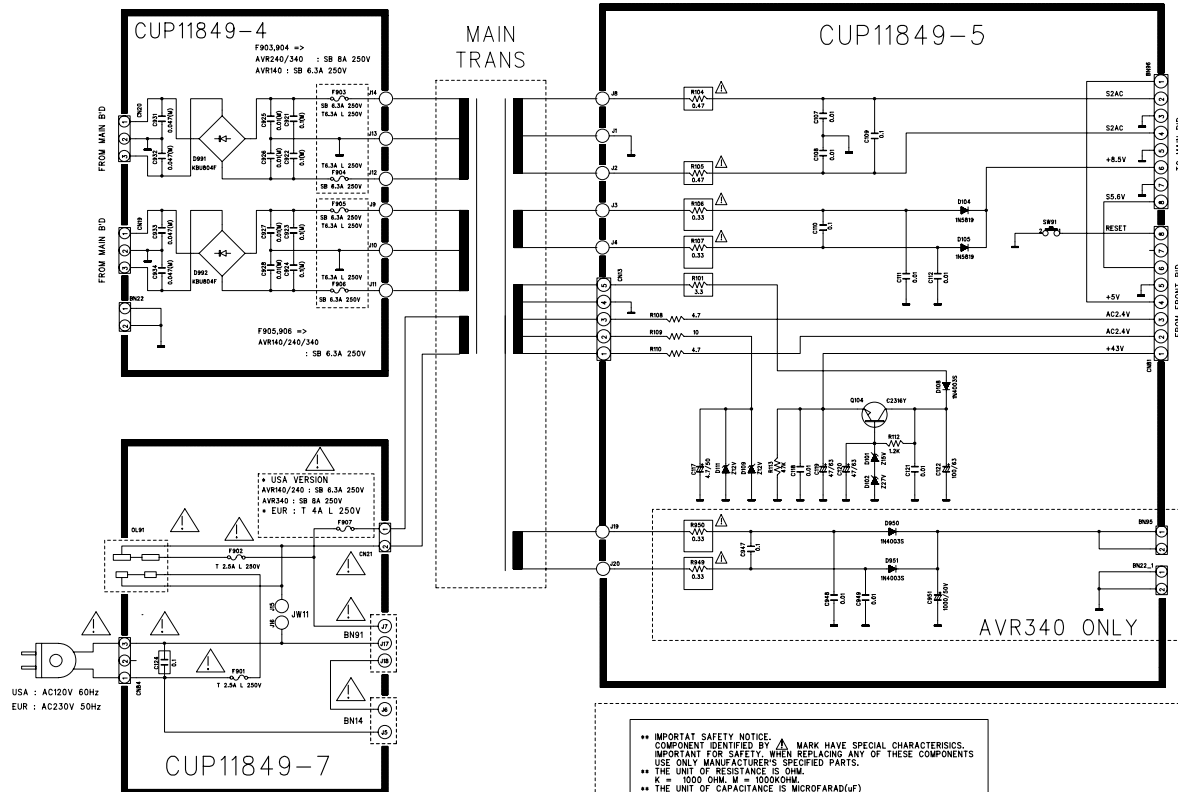
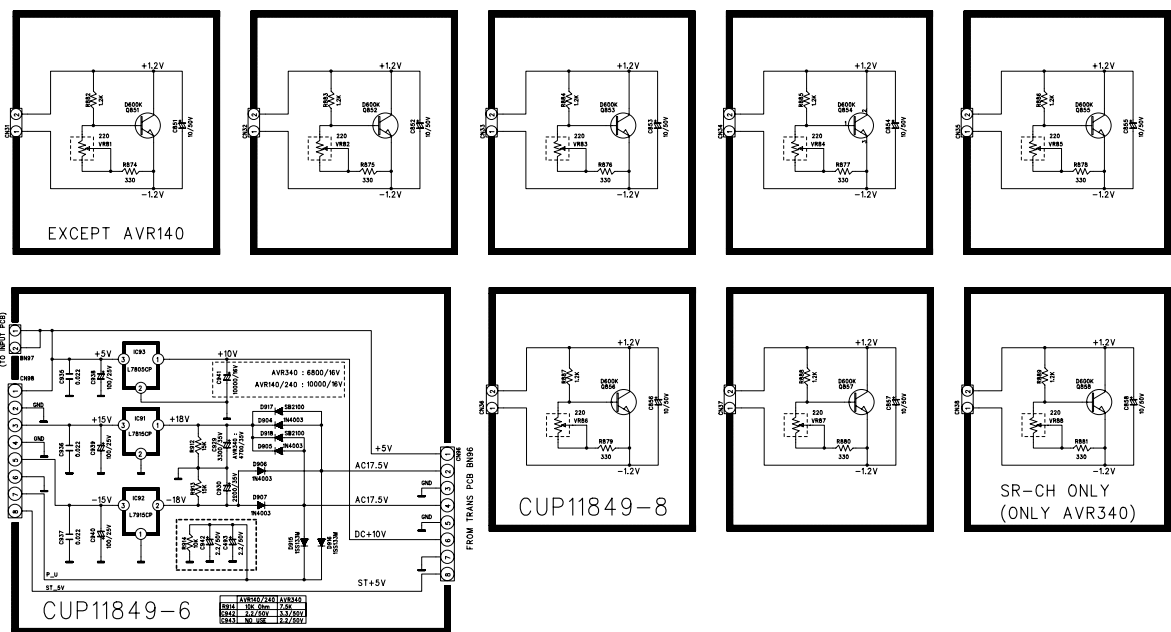

IMPORTANT SAFETY NOTICE:
COMPONENT IDENTIFIED BY Δ MARK HAVE SPECIAL CHARACTERISTICS.
IMPORTANT FOR SAFETY. WHEN REPLACING ANY OF THESE COMPONENTS
USE ONLY MANUFACTURER'S SPECIFIED PARTS.
* THE UNIT OF RESISTANCE IS OHM.
* K = 1000 OHM, M = 10000OHM.
* THE UNIT OF CAPACITANCE IS MICROFARAD(μ F)
* THIS SCHEMATIC DIAGRAM MAY MODIFIED AT ANY TIME WITH THE
IMPROVEMENT OF PERFORMANCE.

< MIC & HP PCB >

AVR240, 340 ONLY

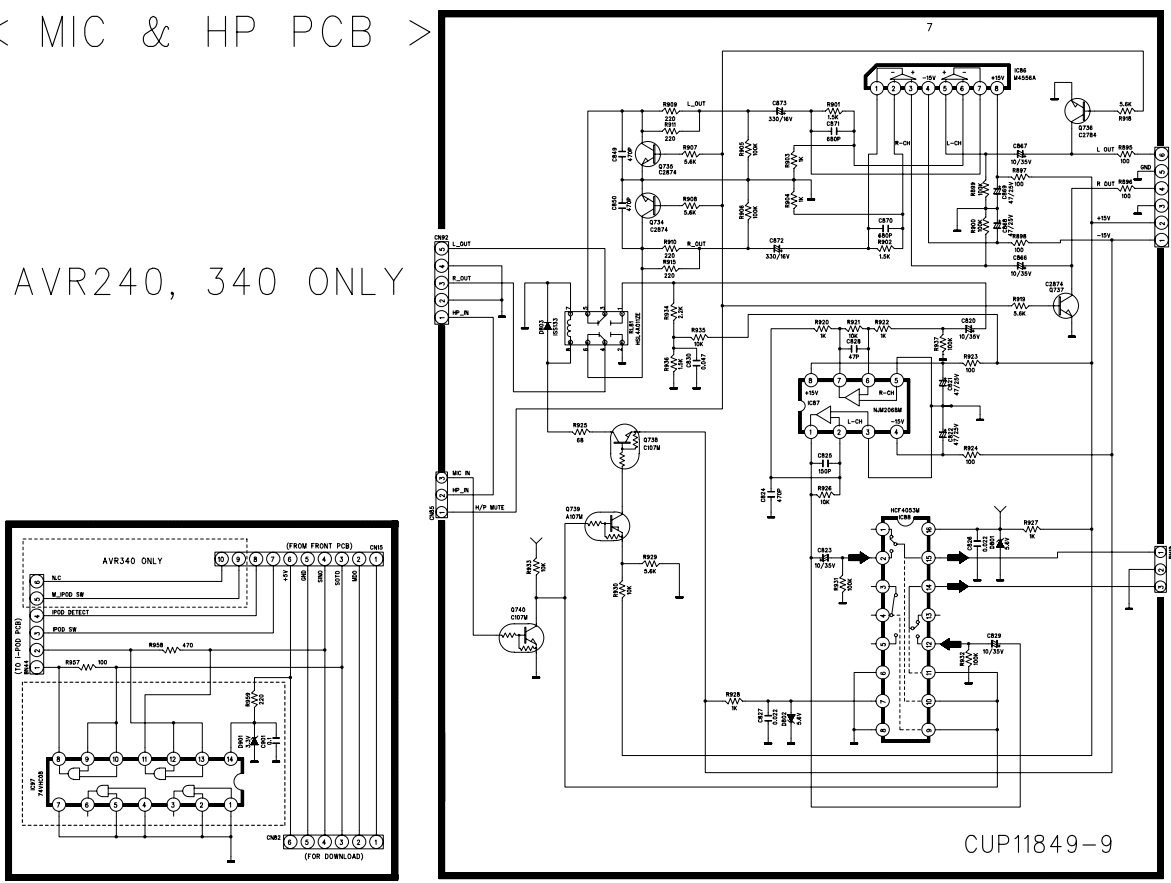

< +24V REGULATOR PCB >

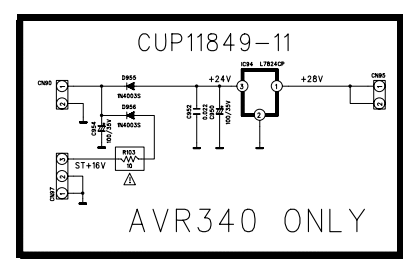

< REMOTE IN/OUT PCB >

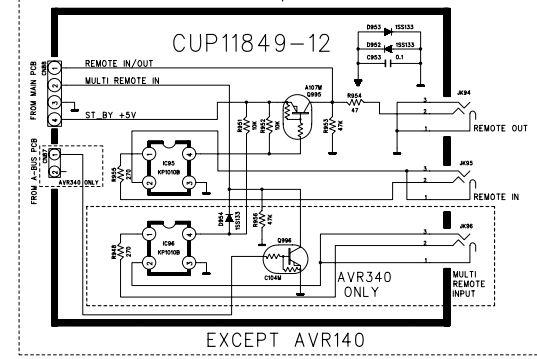

M/P

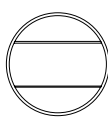

REVISION	2	4	6	
1	3	5	7	
SCHEMATIC DIAGRAM				SHEET
MODEL	AVR140, AVR240, AVR340			7/8
DESIGN	CHECK	APPROVE	DRAWING NO	
LEE C B	Y.W.Y	L.H.W	1849SCMZ	
05.02.03				(BIAS&MIC&POWER TRANS) 2/2

AVR240/340 WIRING DIAGRAM

USA : 120V 60Hz
EUR : 230V 50Hz

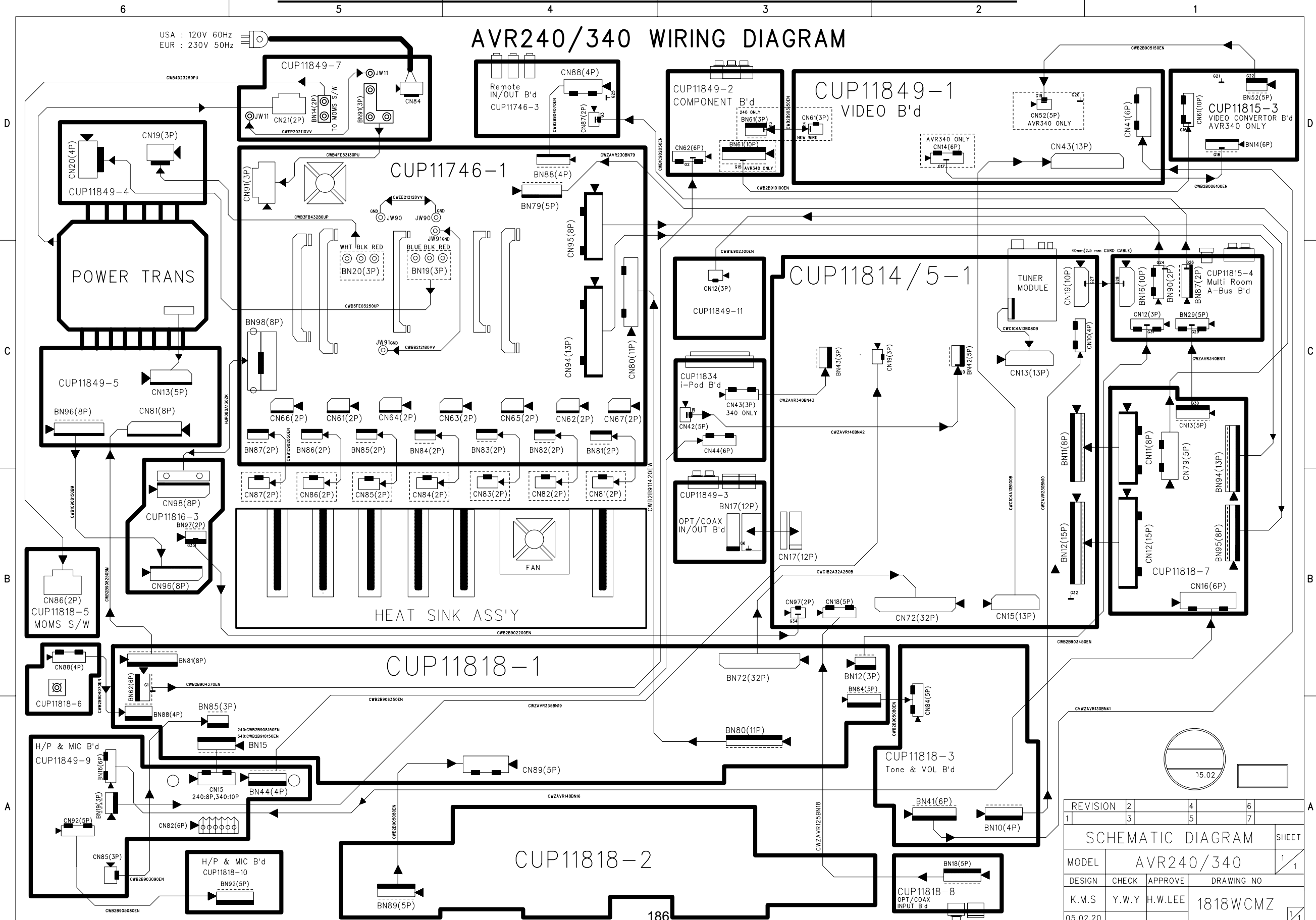

REVISION	2	4	6
	3	5	7
SCHEMATIC DIAGRAM			
MODEL	AVR240/340		
DESIGN	CHECK	APPROVE	DRAWING NO
K.M.S	Y.W.Y	H.W.LEE	1818WCMZ
05.02.20			